



User Manual

AIR-020

Edge AI System

ADVANTECH

Enabling an Intelligent Planet

Attention!

This product contains a hard copy of the Chinese user manual for China CCC certification purposes. A PDF of the English user manual is included on the accompanying CD. Please disregard the hard copy Chinese user manual if the product is not sold and/or installed in China.

Copyright

The documentation and the software included with this product are copyrighted 2022 by Advantech Co., Ltd. All rights are reserved. Advantech Co., Ltd. reserves the right to make improvements in the products described in this manual at any time without notice. No part of this manual may be reproduced, copied, translated, or transmitted in any form or by any means without the prior written permission of Advantech Co., Ltd. The information provided in this manual is intended to be accurate and reliable. However, Advantech Co., Ltd. assumes no responsibility for its use, nor for any infringements of the rights of third parties that may result from its use.

Acknowledgments

Award is a trademark of Award Software International, Inc VIA is a trademark of VIA Technologies, Inc.

IBM, PC/AT, PS/2 and VGA are trademarks of International Business Machines Corporation.

Intel[®] and Pentium[®] are trademarks of Intel Corporation Microsoft Windows[®] is a registered trademark of Microsoft Corp RTL is a trademark of Realtek Semi-Conductor Co., Ltd.

ESS is a trademark of ESS Technology, Inc.

UMC is a trademark of United Microelectronics Corporation SMI is a trademark of Silicon Motion, Inc.

Creative is a trademark of Creative Technology LTD CHRONTEL is a trademark of Chronitel Inc.

All other product names or trademarks are properties of their respective owners.

For more information about this or other Advantech products, visit our website at <http://www.advantech.com/>

https://www.advantech.com/products/fanless-embedded-computers/sub_1-2jkeuf

For technical support and customer service, visit our support website at: <http://support.advantech.com.tw/support/>

Product Warranty (2 years)

Advantech warrants the original purchaser that each of its products will be free from defects in materials and workmanship for two years from the date of purchase.

This warranty does not apply to any products that have been repaired or altered by persons other than repair personnel authorized by Advantech, or products that have been subject to misuse, abuse, accident, or improper installation. Advantech assumes no liability under the terms of this warranty as a consequence of such events.

Because of Advantech's high quality-control standards and rigorous testing, most customers never need to use our repair service. If an Advantech product is defective, it will be repaired or replaced free of charge during the warranty period. For out-of-warranty repairs, customers will be billed according to the cost of replacement materials, service time, and freight. Please consult your dealer for more details.

If you believe your product to be defective, follow the steps outlined below.

1. Collect all the information about the problem encountered. (For example, CPU speed, Advantech products used, other hardware and software used, etc.) Note anything abnormal and list any onscreen messages displayed when the problem occurs.
2. Call your dealer and describe the problem. Please have your manual, product, and any helpful information readily available.
3. If your product is diagnosed as defective, obtain a return merchandise authorization (RMA) number from your dealer. This allows us to process your return more quickly.
4. Carefully pack the defective product, a completed Repair and Replacement Order Card, and a proof of purchase date (such as a photocopy of your sales receipt) into a shippable container. Products returned without a proof of purchase date are not eligible for warranty service.
5. Write the RMA number clearly on the outside of the package and ship the package prepaid to your dealer.

Declaration of Conformity

FCC Class B

This equipment has been tested and found to comply with the limits for a Class B digital device, pursuant to part 15 of the FCC Rules. These limits are designed to provide reasonable protection against harmful interference in a residential installation. This equipment generates, uses, and can radiate radio frequency energy and, if not installed and used in accordance with the instruction manual, may cause harmful interference to radio communications. However, there is no guarantee that interference will not occur in a particular installation. If this equipment does cause harmful interference to radio or television reception, which can be determined by turning the equipment off and on, the user is encouraged to try to correct the interference by one or more of the following measures:

- Reorient or relocate the receiving antenna.
- Increase the separation between the equipment and receiver.
- Connect the equipment into an outlet on a circuit different from that to which the receiver is connected.
- Consult the dealer or an experienced radio/TV technician for assistance.

Technical Support and Assistance

1. Visit the Advantech website at www.advantech.com/support to obtain the latest product information.
2. Contact your distributor, sales representative, or Advantech's customer service center for technical support if you need additional assistance. Please have the following information ready before calling:
 - Product name and serial number
 - Description of your peripheral attachments
 - Description of your software (operating system, version, application software, etc.)
 - A complete description of the problem
 - The exact wording of any error messages

Warnings, Cautions, and Notes

Warning! *Warnings indicate conditions that if not observed can cause personal injury!*



Les avertissements indiquent des conditions qui, si elles ne sont pas observées, peuvent entraîner blessure!

Caution! *Cautions are included to help prevent hardware damage and data losses. For example:*



“Batteries are at risk of exploding if incorrectly installed. Do not attempt to recharge, force open, or heat the battery. Replace the battery only with the same or equivalent type as recommended by the manufacturer. Discard used batteries according to the manufacturer's instructions.”
Des précautions sont incluses pour éviter les dommages matériels et les données pertes.

Note! *Notes provide additional optional information.*



Packing List

Before system installation, check that the items listed below are included and in good condition. If any item does not accord with the list, contact your dealer immediately.

- 1 x AIR-020 unit
- 1 x Registration and 2-year warranty card
- 1 x China RoHS
- 1 x Simplified Chinese user manual

Ordering Information

| Model Number | Description |
|---------------|---|
| AIR-020X-S9A1 | Edge AI NVIDIA Xavier NX inference system |
| AIR-020T-U0A1 | Edge AI NVIDIA TX2 NX inference system |
| AIR-020N-S4A1 | Edge AI NVIDIA Nano inference system |

Optional Accessories

| Part Number | Description |
|------------------|---|
| 96PSA-A65W19P2-1 | Power adapter 100-240V 65W 19V |
| 1702002600 | Power cord UL 3P 10A 125V 183 cm (US) |
| 1702002605 | Power cord EU 3P 2.5A 250V 183 cm (EU) |
| 1702031801 | Power cord BSI 3P 2.5A 250V 183 cm (UK) |
| AMK-W005 | Wall mounting kit |

Safety Instructions

1. Read these safety instructions carefully.
2. Retain this user manual for future reference.
3. Disconnect the equipment from all power outlets before cleaning. Use only a damp cloth for cleaning. Do not use liquid or spray detergents.
4. For pluggable equipment, the power outlet socket must be located near the equipment and easily accessible.
5. Protect the equipment from humidity.
6. Place the equipment on a reliable surface during installation. Dropping or letting the equipment fall may cause damage.
7. The openings on the enclosure are for air convection. Protect the equipment from overheating. Do not cover the openings.
8. By means of a power cord connected to a socket-outlet with earthing connection.
9. Position the power cord away from high-traffic areas. Do not place anything over the power cord.
10. All cautions and warnings on the equipment should be noted.
11. If the equipment is not used for a long time, disconnect it from the power source to avoid damage from transient over-voltage.
12. Never pour liquid into an opening. This may cause fire or electrical shock.
13. Never open the equipment. For safety reasons, the equipment should be opened only by qualified service personnel.
14. If any of the following occurs, have the equipment checked by service personnel:
 - The power cord or plug is damaged.
 - Liquid has penetrated the equipment.
 - The equipment has been exposed to moisture.
 - The equipment is malfunctioning, or does not operate according to the user manual.
 - The equipment has been dropped and damaged.
 - The equipment shows obvious signs of breakage.
15. Do not leave the equipment in an environment with a storage temperature of below $-40\text{ }^{\circ}\text{C}$ ($-40\text{ }^{\circ}\text{F}$) or above $85\text{ }^{\circ}\text{C}$ ($185\text{ }^{\circ}\text{F}$) as this may damage the components. The equipment should be kept in a controlled environment.
16. Any unverified component may cause unexpected damage. To ensure correct installation, always use the components (e.g., screws) provided in the accessory box.
17. **CAUTION:** Batteries are at risk of exploding if incorrectly replaced. Replace only with the same or equivalent type as recommended by the manufacturer. Discard used batteries according to the manufacturer's instructions.
18. Always disconnect the power cord from the chassis before manually handling the hardware. Do not implement connections or configuration changes while the device is powered on. Sudden power surges may damage sensitive electronic components.
19. In accordance with IEC 704-1:1982 specifications, the sound pressure level at the operator's position does not exceed 70 dB (A).
20. **DISCLAIMER:** These instructions are provided according to IEC 704-1 standards. Advantech disclaims all responsibility for the accuracy of any statements contained herein.
21. This product is intended to be supplied by an UL Listed power Adapter, or DC power source, rated: 19Vdc, 4.74A, T_{ma}=55 degrees C, if need further assis-

tance, please contact Advantech for further information (Tma 50 degree C=Operating temperature)

22. RESTRICTED ACCESS AREA: The equipment should only be installed in a Restricted Access Area.

Consignes de Sécurité

1. Veuillez lire attentivement ces instructions de sécurité.
2. Veuillez conserver ce manuel de l'utilisateur pour référence ultérieure.
3. Veuillez débrancher cet équipement de la prise secteur avant le nettoyage. Utilisez un chiffon humide. Ne pas utiliser de détergent liquide ou pulvérisé pour le nettoyage. Utilisez une feuille ou un chiffon humide pour le nettoyage.
4. Pour les équipements enfichables, la prise de courant doit être à proximité de l'équipement et doit être facilement accessible.
5. S'il vous plaît garder cet équipement de l'humidité.
6. Posez cet équipement sur une surface fiable lors de l'installation. Une chute ou une chute pourrait causer des blessures.
7. Les ouvertures sur le boîtier sont destinées à la convection d'air, protégeant ainsi l'équipement de la surchauffe. **NE COUVREZ PAS LES OUVERTURES.**
8. Au moyen d'un cordon d'alimentation connecté à une prise de courant avec mise à la terre.
9. Placez le cordon d'alimentation de sorte que personne ne puisse marcher dessus. Ne placez rien sur le cordon d'alimentation.
10. Tous les avertissements et mises en garde sur l'équipement doivent être notés.
11. Si l'appareil n'est pas utilisé pendant une longue période, débranchez-le du secteur pour ne pas être endommagé par une surtension transitoire.
12. Ne jamais verser de liquide dans les ouvertures de ventilation; Cela pourrait provoquer un incendie ou un choc électrique.
13. N'ouvrez jamais l'équipement. Pour des raisons de sécurité, seul le personnel de maintenance qualifié doit ouvrir l'équipement.
14. Si l'une des situations suivantes se présente, faites vérifier le matériel par le personnel de service:
 - Le cordon d'alimentation ou la fiche est endommagé.
 - Un liquide a pénétré dans l'appareil.
 - L'équipement a été exposé à l'humidité.
 - L'équipement ne fonctionne pas bien ou vous ne pouvez pas le faire fonctionner conformément au manuel d'utilisation.
 - Equipment L'équipement est tombé et a été endommagé.
 - Equipment L'équipement présente des signes évidents de rupture.
15. Ne laissez pas cet équipement dans un environnement où la température de stockage peut être inférieure à -40° C (-40° F) ou supérieure à 85° C (185° F). Cela pourrait endommager l'équipement. L'équipement doit être dans un environnement contrôlé.
16. Tout composant non vérifié peut causer des dommages inattendus. Pour garantir une installation correcte, veuillez toujours utiliser les composants (ex. Vis) fournis avec la boîte d'accessoires.
17. ATTENTION: L'ordinateur est équipé d'un circuit d'horloge temps réel alimenté par batterie. Il y a un risque d'explosion si la batterie est remplacée de manière incorrecte. Remplacez uniquement avec le même type ou un type équivalent recommandé par le fabricant. Jetez les piles usagées conformément aux instructions du fabricant.

18. Débranchez toujours complètement le cordon d'alimentation de votre châssis lorsque vous utilisez du matériel. Ne faites pas de connexion quand l'appareil est sous tension. Les composants électroniques sensibles peuvent être endommagés par des surtensions soudaines.
19. Niveau de pression acoustique au poste de l'opérateur selon la norme CEI 704-1: 1982 n'est pas supérieur à 70 dB (A).
20. **AVERTISSEMENT:** Cet ensemble d'instructions est donné conformément à la norme CEI 704-1. Advantech décline toute responsabilité quant à l'exactitude des déclarations contenues dans ce.
21. Ce produit est destiné à être alimenté par un adaptateur secteur répertorié UL ou une source d'alimentation CC, évalué: 19Vdc, 4.74A, T_{ma} = 50 degrés C, si besoin d'assistance supplémentaire, veuillez contacter Advantech pour plus d'informations. (T_{ma} 55 degrés C = Fonctionnement Température)
22. **ZONE D'ACCES RESTREINTE:** L'équipement ne doit être installé que dans une zone d'accès restreint.

Contents

Chapter 1 General Introduction1

| | | |
|-------|------------------------------------|---|
| 1.1 | Introduction | 2 |
| 1.2 | Product Features..... | 2 |
| 1.2.1 | General | 2 |
| 1.2.2 | Display | 3 |
| 1.2.3 | Ethernet | 3 |
| 1.2.4 | I/O Ports and Expansion | 3 |
| 1.2.5 | CPU | 3 |
| 1.2.6 | GPU | 3 |
| 1.3 | Mechanical Specifications..... | 4 |
| 1.3.1 | System Dimensions | 4 |
| 1.3.2 | Weight..... | 5 |
| 1.4 | Power Requirements..... | 5 |
| 1.4.1 | System Power..... | 5 |
| 1.4.2 | RTC Battery | 5 |
| 1.5 | Environmental Specifications | 6 |
| 1.5.1 | Operating Temperature..... | 6 |
| 1.5.2 | Relative Humidity | 6 |
| 1.5.3 | Storage Temperature..... | 6 |
| 1.5.4 | Vibration Tolerance..... | 6 |
| 1.5.5 | Shock Tolerance..... | 6 |
| 1.5.6 | Safety Certification..... | 6 |
| 1.5.7 | EMC Certification | 6 |

Chapter 2 Hardware Installation7

| | | |
|-------|--|----|
| 2.1 | Introduction | 8 |
| 2.2 | Jumpers | 8 |
| 2.2.1 | Jumper Description | 8 |
| 2.2.2 | Jumper List | 8 |
| | Table 2.1: Jumper Setting | 8 |
| 2.2.3 | Jumper Location | 9 |
| | Table 2.2: JPSON1 Auto Power On Setting (A) | 9 |
| | Table 2.3: RECOVERY1 Recovery Button (B) | 9 |
| | Table 2.4: RESET1 Recovery Button (C)..... | 9 |
| | Table 2.5: COM1_SW1 (D)/COM2_SW1 (F) COM Port Setting .. | 10 |
| | Table 2.6: COM1_SW2 (E)/COM2_SW2 (G) COM Port Debug... | 10 |
| | Table 2.7: MPWR_SEL1 mPCIE Voltage Setting (H)..... | 10 |
| 2.3 | I/O Introduction..... | 11 |
| 2.4 | External I/O | 12 |
| 2.4.1 | Power On/Off Button..... | 12 |
| | Figure 2.1 Power On/Off Button | 12 |
| 2.4.2 | Power Input Connector | 12 |
| 2.4.3 | Ethernet Connector (LAN) | 12 |
| | Figure 2.2 Ethernet Connector (LAN) | 12 |
| | Table 2.8: Ethernet Connector (LAN) Pin Definition..... | 12 |
| 2.4.4 | USB 3.0 Connector | 13 |
| | Figure 2.3 USB Connector..... | 13 |
| | Table 2.9: USB Connector Pin Definition | 13 |
| 2.4.5 | COM Connector | 13 |
| | Figure 2.4 COM Connector..... | 13 |
| | Table 2.10: COM Connector Pin Definition | 13 |

| | | |
|--------|---|----|
| 2.4.6 | HDMI Connector..... | 14 |
| | Figure 2.5 HDMI Connector..... | 14 |
| | Table 2.11: HDMI Connector Pin Definition | 14 |
| 2.4.7 | Antenna Socket | 14 |
| | Figure 2.6 Antenna Socket..... | 14 |
| 2.4.8 | USB Type C..... | 15 |
| 2.4.9 | Micro USB for OTG..... | 16 |
| 2.4.10 | Digital I/O..... | 16 |
| 2.4.11 | CANBUS Port and Pin Definition | 17 |
| 2.5 | Installation..... | 18 |
| 2.5.1 | M.2 Installation..... | 18 |
| 2.5.2 | Mini PCIe Installation | 20 |

Chapter 1

General Introduction

This chapter gives background information on AIR-020 series.

1.1 Introduction

Advantech's AIR-020 is an ultra-compact series of edge AI systems powered by NVIDIA Jetson. Featuring a small footprint of just 138 x 109.8 x 43.6 mm (5.43 x 4.32 x 1.72 in), the AIR-020 series delivers low-power computing with powerful AI inferring capabilities utilizing NVIDIA Jetson Nano, TX2 NX, and Xavier NX SoM.

Scalable and powerful AI performance with NVIDIA Jetson family

AIR-020X is powered by the NVIDIA Xavier NX SoM. Conversely, AIR-020T is powered by Jetson TX2 NX. And, AIR-020N is powered by Jetson Nano. These three ultra-compact offerings weigh just 0.85 kg (1.87 lb). AIR-020X supports up to 21 TOPS (Tera Operations per Second) and 1058 frames per second (FPS) targeting high-resolution imaging processes. AIR-020T and AIR-020N support 1.33/0.5 TFLOPS and up to 109/48 frames per second (FPS). The AIR-020 series provides wide-range 12 ~ 24Vdc input and wide operating temperatures (-10 ~ 55 °C; 14 ~ 131 °F). This durability is buttressed by advanced vibration and humidity resistance.

Robust I/O and connectivity: camera, wireless, and peripheral integration

Advantech's AIR-020 series features diverse I/O ports — including 2 x USB 3.2 Type A, USB 3.2 Type C, 1 or 2 x GbE, 1 or 2 x RS-232/422/485, 8-bit DIO, and CANBus for data acquisition and communication. The ultra-compact AI boxes are pre-installed with 4GB/8GB LPDDR4 and 16GB eMMC 5.1. Moreover, AIR-020 series provides 128GB of M.2 storage as standard offering for data storage in diverse AI applications.

1.2 Product Features

1.2.1 General

| | AIR-020X | AIR-020T | AIR-020N |
|--------------------|------------------------------------|--|-----------------------------------|
| CPU | ARM v8.2 | Dual-core NVIDIA Denver 2 64-bit CPU and quad-core ARM A57 Complex | Quad core ARM Cortex® A57 |
| GPU | Volta 384 CUDA and 48 Tensor cores | Pascal 256 CUDA | Maxwell 128 CUDA |
| Memory | 8GB LPDDR4 | 4GB LPDDR4 | 4GB LPDDR4 |
| Storage | 16GB eMMC 5.1 128GB M.2 | 16GB eMMC 5.1 128GB M.2 | 16GB eMMC 5.1 128GB M.2 |
| Serial Port | 2 x RS-232/422/485 | 1 x RS-232/422/485 | 1 x RS-232/422/485 |
| USB Type A | 2 x USB 3.2 Gen 2 | 2 x USB 3.2 Gen 1 | 2 x USB 3.2 Gen 1 |
| USB Type C | 1 x USB 3.2 Gen 2 | 1 x USB 3.2 Gen 1 | 1 x USB 3.2 Gen 1 |
| Expansion | Full-size mPCIe | Full-size mPCIe | Full-size mPCIe (USB signal only) |

1.2.2 Display

- **Resolution:** 1x HDMI 2.0, max. 3840x2160@30Hz

1.2.3 Ethernet

- **Chipset:**
 - LAN1 NVIDIA Jetson SoM series
 - LAN2 Intel® i210AT
- **Speed:** 10/100/1000 Mbps
- **Interface:** 2 x RJ45 (AIR-020X/T), 1 x RJ45 (AIR-020N, LAN1)
- **Standard:** Compliant with IEEE 802.3, IEEE 802.3u, IEEE 802.3ab.

1.2.4 I/O Ports and Expansion

- 1 x HDMI 2.0b, max. 3840x2160@30Hz
- 2 x USB 3.2 Type A/1 x USB 3.2 Type C
- 1 x 8-bit DI/DO
- 2/1 x RS-232/RS-422/RS-485 (AIR-020X/AIR-020T & AIR-020N)
- 1 x CANBus (AIR-020X)
- 1 x OTG Micro USB
- 1 x Full-size mPCIe
- 1 x M.2 2280 M key, 128GB storage built-in

1.2.5 CPU

- **AIR-020X:** ARM v8.2
- **AIR-020T:** Dual-core NVIDIA Denver2 and quad-core ARM A57 Complex
- **AIR-020N:** Quad core ARM Cortex® A57

1.2.6 GPU

- **AIR-020X:** Volta 384 CUDA and 48 Tensor cores
- **AIR-020T:** Pascal 256 CUDA
- **AIR-020N:** Quad core ARM Cortex® A57

1.3 Mechanical Specifications

1.3.1 System Dimensions

138 x 109.8 x 43.6 mm (5.43 x 4.32 x 1.72 in)

AIR-020X:

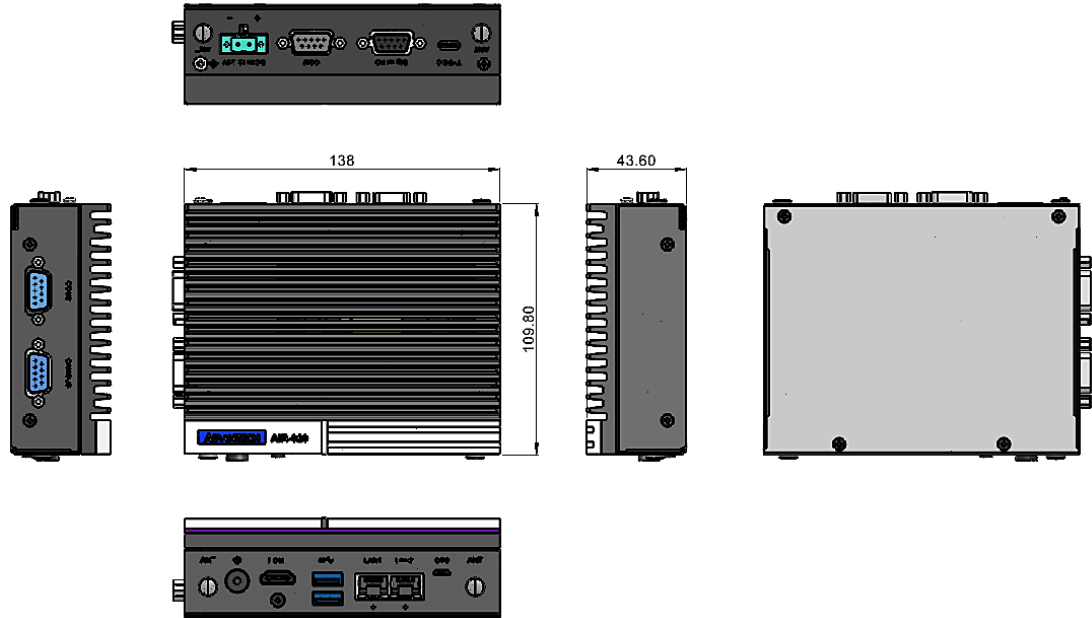

AIR-020T:

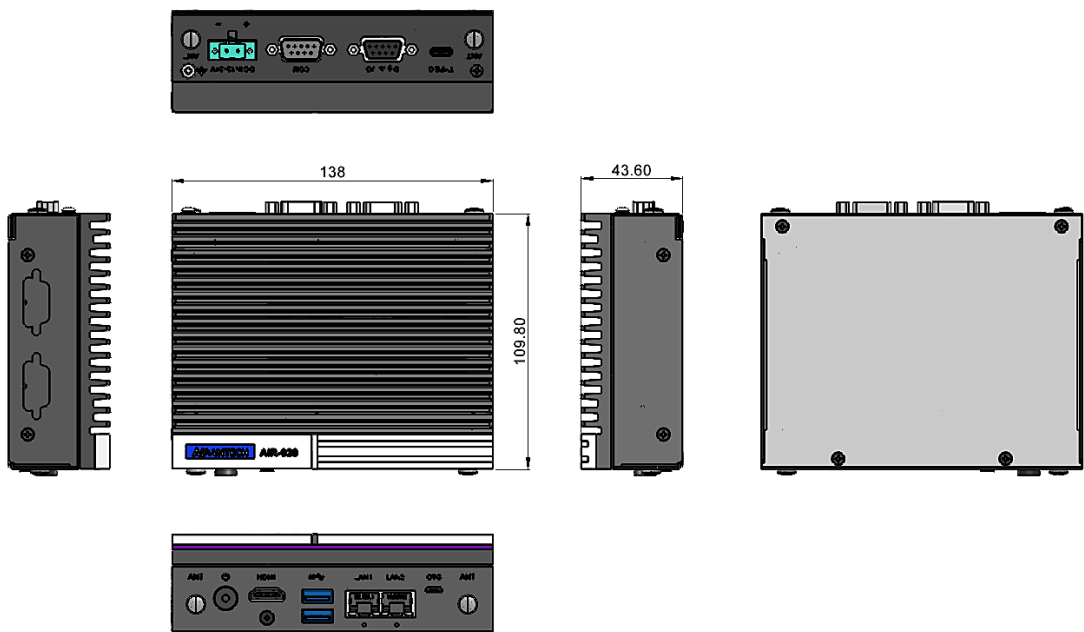

AIR-020N:

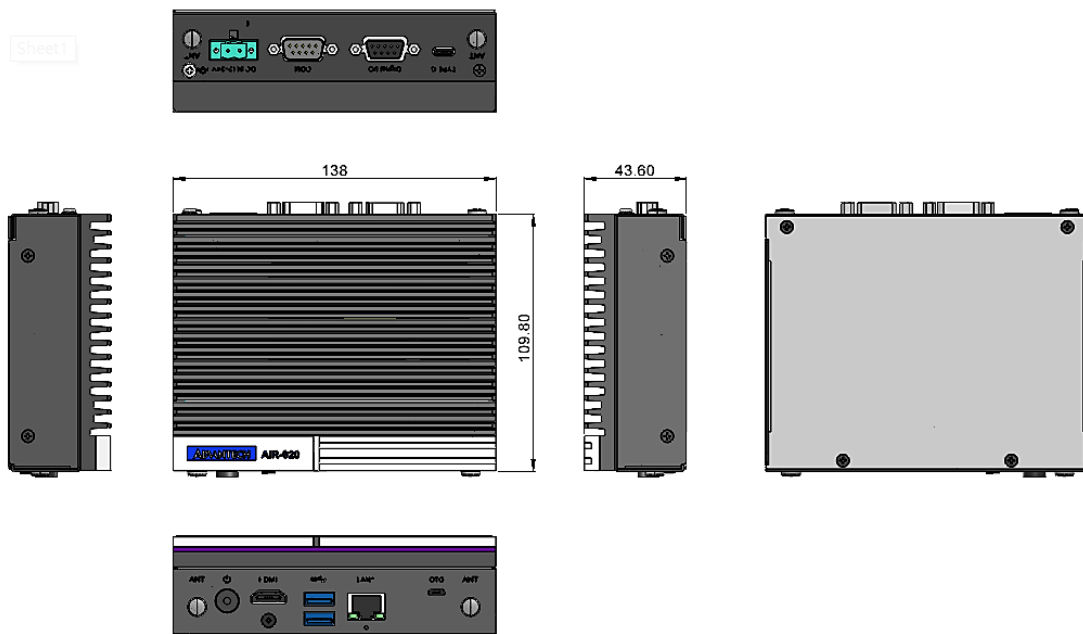

Wall mounting Kit:

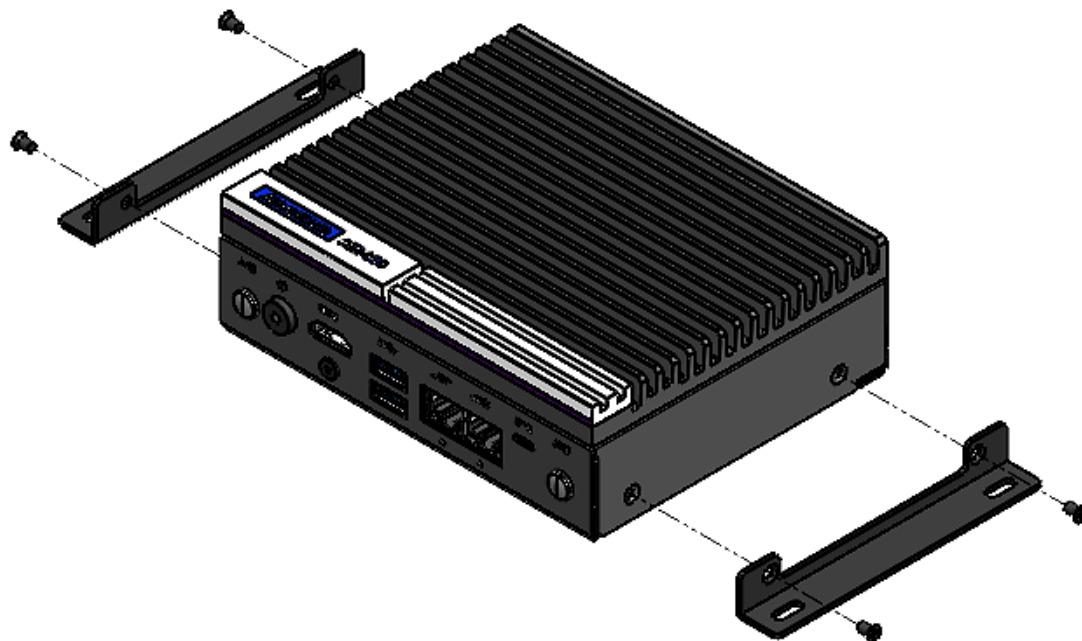

1.3.2 Weight

0.85 kg (1.87 lb)

1.4 Power Requirements

1.4.1 System Power

- Power Input: DC In 12 ~ 24V

1.4.2 RTC Battery

- Lithium: 3 V/210 mA

1.5 Environmental Specifications

1.5.1 Operating Temperature

- -10 ~ 55 °C (-14 ~ 131 °F), with 0.7m/s air flow

1.5.2 Relative Humidity

- 95% @ 40 °C (104 °F) (non-condensing)

1.5.3 Storage Temperature

- -40 ~ 85 °C (-40 ~ 185 °F)

1.5.4 Vibration Tolerance

- When the system is equipped with an SSD/mSATA: 3 Grms, IEC 60068-2-64, random, 5 ~ 500 Hz, 1 hr/axis, (x, y, z) 3 axes

1.5.5 Shock Tolerance

- When the system is equipped with an SSD/mSATA: 30 G, IEC 60068-2-27, half sine, 11 ms duration

1.5.6 Safety Certification

- UL, CB, and CCC

1.5.7 EMC Certification

- CE, FCC Class B, CCC, and BSMI

Chapter 2

Hardware Installation

This chapter details instructions for installing AIR-020 hardware and external I/O

2.1 Introduction

The following sections demonstrate the internal jumper settings and the external connector pin assignments.

2.2 Jumpers

2.2.1 Jumper Description

AIR-020 can be configured to satisfy specific application requirements by setting jumpers. A jumper is a metal bridge used to close an electric circuit. It consists of two metal pins and a small metal clip (often protected by a plastic cover) that slides over the pins to connect them. To close a jumper, connect the pins with the clip. To open a jumper, remove the clip. Sometimes a jumper will have three pins, labeled 1, 2, and 3. For these jumpers, connect either pins 1 and 2, or 2 and 3.

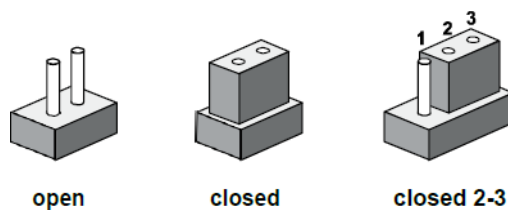

The jumper settings are schematically diagrammed in this manual as follows:

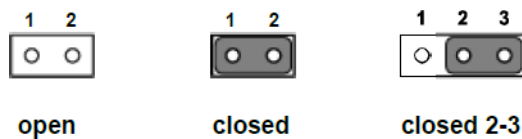

A pair of needle-nose pliers may be necessary when working with jumpers. Users with concerns regarding the ideal hardware configuration for your application should contact your local distributor or sales representative before making any changes. Usually, only a standard cable is required to make most connections.

2.2.2 Jumper List

Table 2.1: Jumper Setting

| Location | Function |
|-------------------|------------------------|
| JPERSON1 | Auto Power On Setting |
| RECOVERY1 | System recovery button |
| RESET1 | System reset button |
| COM1_SW1/COM2_SW1 | COM port setting |
| COM1_SW2/COM2_SW2 | COM port debug |
| MPWR_SEL1 | mPCIE voltage setting |

2.2.3 Jumper Location

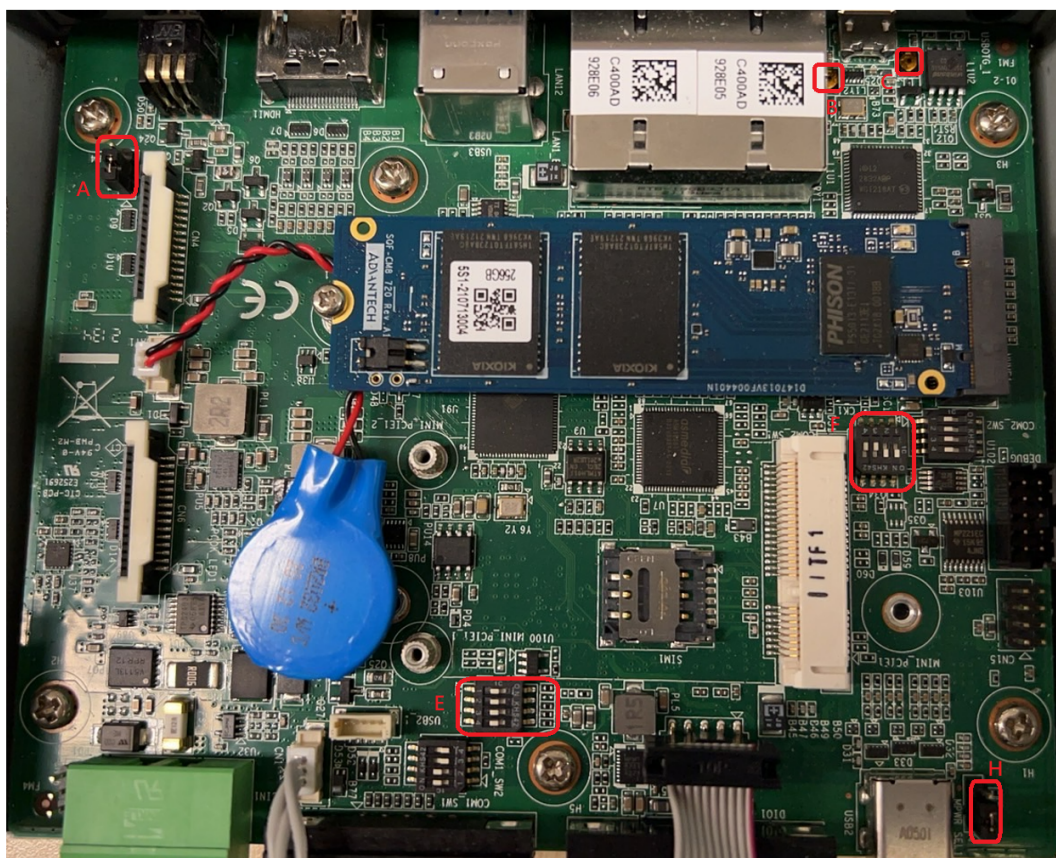

Table 2.2: JPSON1 Auto Power On Setting (A)

| | |
|--------------------|---|
| Part Number | 1653003101 |
| Description | PIN HEADER 3 x 1P 2.0 mm 180D(M) DIP 2000-13 WS |
| Default Setting | (2-3): ATX mode |
| Jumper Setting | (1-2): AT mode |

Table 2.3: RECOVERY1 Recovery Button (B)

| | |
|-------------|----------------------------|
| Description | Button for system recovery |
|-------------|----------------------------|

Table 2.4: RESET1 Recovery Button (C)

| | |
|-------------|-------------------------|
| Description | Button for system reset |
|-------------|-------------------------|

Table 2.5: COM1_SW1 (D)/COM2_SW1 (F) COM Port Setting

| | |
|-----------------|------------------|
| Description | COM mode setting |
| Default Setting | RS-232 |

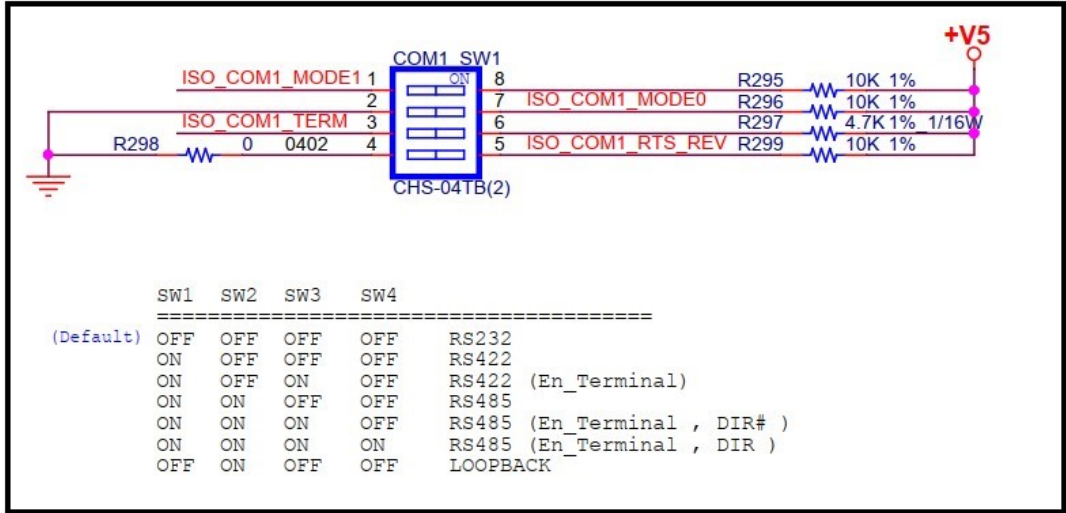

Table 2.6: COM1_SW2 (E)/COM2_SW2 (G) COM Port Debug

| | |
|-------------|---------------------------|
| Description | Terminal resistor for COM |
|-------------|---------------------------|

Table 2.7: MPWR_SEL1 mPCIE Voltage Setting (H)

| | |
|--------------------|---|
| Part Number | 1653003101 |
| Description | PIN HEADER 3x1P 2.0mm 180D(M) DIP 2000-13 WS |
| Default setting | (1-2): 3.3V |
| Jumper setting | (2-3): 3.8V for specific 5G module (eg: AIW-355 series) |

2.3 I/O Introduction

**Front View
AIR-020N**

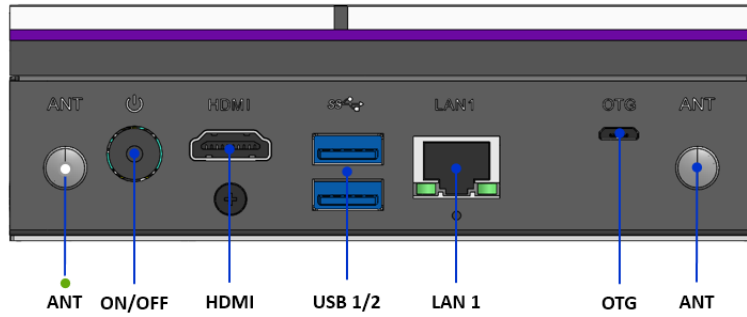

AIR-020T/AIR-020X

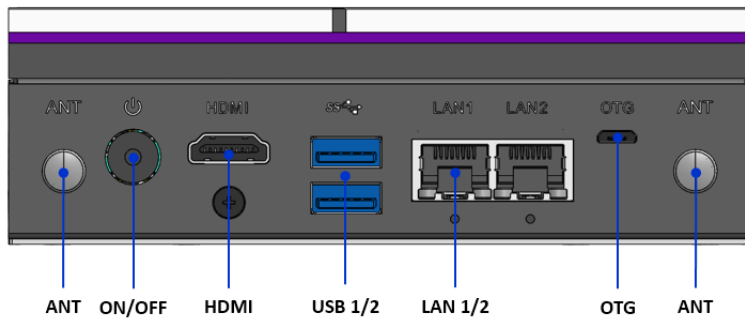

Rear View

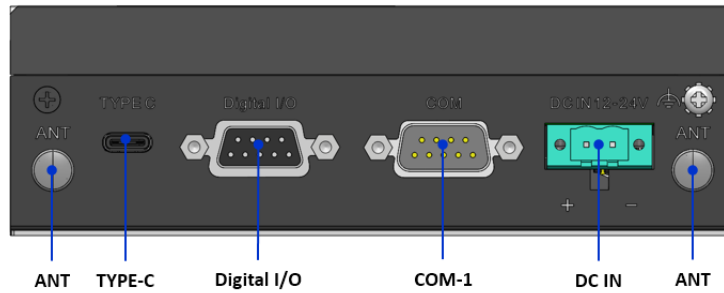

**Side View
AIR-020X**

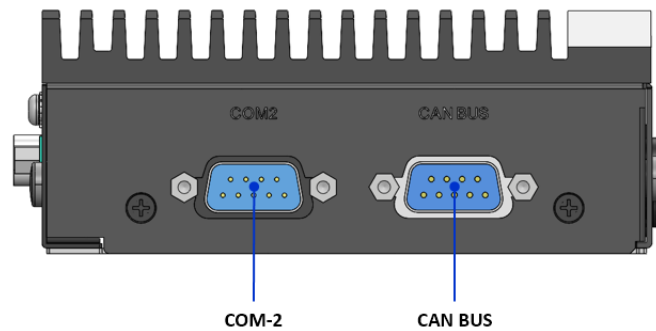

2.4 External I/O

2.4.1 Power On/Off Button

AIR-020 features a Power On/Off button with an LED indicators on the top side that show On status (Green LED).



Figure 2.1 Power On/Off Button

2.4.2 Power Input Connector

The power input connector supports DC in 12 ~ 24V, 19V adapter built-in.

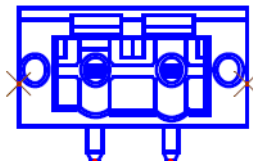

2.4.3 Ethernet Connector (LAN)

AIR-020 is equipped with GbEs and the Ethernet controllers are fully compliant with IEEE 802.3u 10/100/1000 Mbps CSMA/CD standards and connected to LAN1 and LAN2. The Ethernet port provides a standard RJ45 jack connector with LED indicators on the front side to show its Active/Link (Green LED) and Speed statuses (Yellow LED).

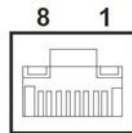

Figure 2.2 Ethernet Connector (LAN)

Table 2.8: Ethernet Connector (LAN) Pin Definition

| Pin | 10/100/1000 Mbps Signal Name |
|-----|------------------------------|
| 1 | BI_DA+(GHz) |
| 2 | BI_DA-(GHz) |
| 3 | BI_DB+(GHz) |
| 4 | BI_DC+(GHz) |
| 5 | BI_DC-(GHz) |
| 6 | BI_DB-(GHz) |
| 7 | BI_DD+(GHz) |
| 8 | BI_DD-(GHz) |
| H3 | GND |
| H4 | GND |

2.4.4 USB 3.0 Connector

AIR-020 supports 2 x USB 3.2 Type A interfaces. These support Plug-and-Play functionality and hot swapping for up to 127 x external devices.



Figure 2.3 USB Connector

Table 2.9: USB Connector Pin Definition

| Pin | Signal Name |
|-----|-------------|
| 1 | +5V |
| 2 | D-_0 |
| 3 | D+_0 |
| 4 | GND |
| 5 | USB0_SSRX- |
| 6 | USB0_SSRX+ |
| 7 | GND |
| 8 | USB0_SSTX- |
| 9 | USB0_SSTX+ |

2.4.5 COM Connector

AIR-020 provides two 9-pin D-sub connector, which supports RS232/422/485 serial communication interface ports. The default setting is RS-232, if you want to use RS-422/485, you can use the BIOS manual to change settings.

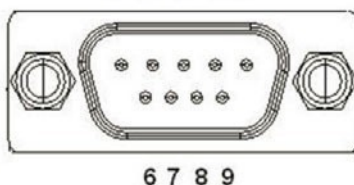

Figure 2.4 COM Connector

Table 2.10: COM Connector Pin Definition

| Pin | RS-232 | RS-422 | RS-485 |
|-----|--------|--------|--------|
| 1 | DCD | Tx- | DATA- |
| 2 | RxD | Tx+ | DATA+ |
| 3 | TxD | Rx+ | NC |
| 4 | DTR | Rx- | NC |
| 5 | GND | GND | GND |
| 6 | DSR | NC | NC |
| 7 | RTS | NC | NC |
| 8 | CTS | NC | NC |
| 9 | RI | NC | NC |

NC represents "No Connection".

2.4.6 HDMI Connector

AIR-020 offers integrated 19-pin receptacle connector HDMI 2.0b interfaces. The HDMI link supports resolutions up to 4096 x 2304 @ 60 Hz.

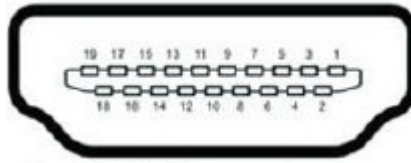

Figure 2.5 HDMI Connector

Table 2.11: HDMI Connector Pin Definition

| Pin | Signal Name |
|-----|--------------|
| 1 | HDMI_TX2+ |
| 2 | GND |
| 3 | HDMI_TX2- |
| 4 | HDMI_TX1+ |
| 5 | GND |
| 6 | HDMI_TX1- |
| 7 | HDMI_TX0+ |
| 8 | GND |
| 9 | HDMI_TX0- |
| 10 | HDMI_CLK+ |
| 11 | GND |
| 12 | HDMI_CLK- |
| 13 | NC |
| 14 | NC |
| 15 | HDMI_DCLK |
| 16 | HDMI_DDAT |
| 17 | GND |
| 18 | +V5_HDMI-HPD |
| 19 | DDP0_HPD |

NC represents "No Connection".

2.4.7 Antenna Socket

AIR-020 reserves four antenna sockets for installing wireless/LTE device antennas. Each antenna socket is labeled "ANT" for easy identification.



Figure 2.6 Antenna Socket

2.4.8 USB Type C

AIR-020 supports USB Type-C 24 pin USB connector with a rotationally symmetrical connector.

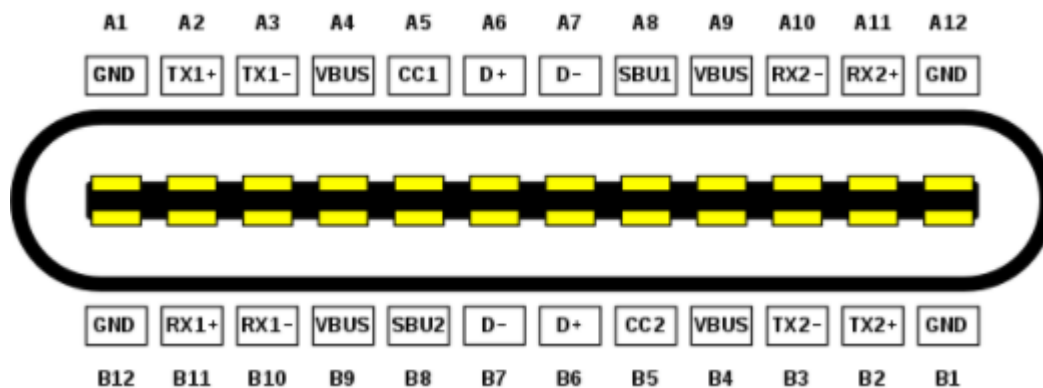

Type-C receptacle A pin layout

| Pin | Name | Description |
|-----|------------------|---|
| A1 | GND | Ground return |
| A2 | SSTXp1 | SuperSpeed differential pair #1, TX, positive |
| A3 | SSTXn1 | SuperSpeed differential pair #1, TX, negative |
| A4 | V _{BUS} | Bus power |
| A5 | CC1 | Configuration channel |
| A6 | Dp1 | USB 2.0 differential pair, position 1, positive |
| A7 | Dn1 | USB 2.0 differential pair, position 1, negative |
| A8 | SBU1 | Sideband use (SBU) |
| A9 | V _{BUS} | Bus power |
| A10 | SSRXn2 | SuperSpeed differential pair #4, RX, negative |
| A11 | SSRXp2 | SuperSpeed differential pair #4, RX, positive |
| A12 | GND | Ground return |

Type-C receptacle B pin layout

| Pin | Name | Description |
|-----|------------------|---|
| B12 | GND | Ground return |
| B11 | SSTXp1 | SuperSpeed differential pair #2, RX, positive |
| B10 | SSTXn1 | SuperSpeed differential pair #2, RX, negative |
| B9 | V _{BUS} | Bus power |
| B8 | SBU2 | Sideband use (SBU) |
| B7 | Dn2 | USB 2.0 differential pair, position 2, negative [a] |
| B6 | Dp2 | USB 2.0 differential pair, position 2, positive [a] |
| B5 | CC2 | Configuration channel |
| B4 | V _{BUS} | Bus power |
| B3 | SSRXn2 | SuperSpeed differential pair #3, TX, negative |
| B2 | SSRXp2 | SuperSpeed differential pair #3, TX, positive |
| B1 | GND | Ground return |

2.4.9 Micro USB for OTG

Micro USB port is supported by OTG for system recovery only.



| Pin | Signal Name |
|-----|-------------|
| 1 | +5V |
| 2 | DATA- |
| 3 | DATA+ |
| 4 | GND_1 |
| 5 | GND_2 |

2.4.10 Digital I/O

AIR-020 offers 8-bit DI/O and pin definition as below.

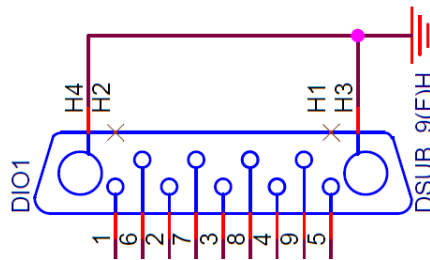

| Pin | Signal Name |
|-----|-------------|
| 1 | DI/O bit 0 |
| 2 | DI/O bit 1 |
| 3 | DI/O bit 2 |
| 4 | DI/O bit 3 |
| 5 | DI/O bit 4 |
| 6 | DI/O bit 5 |
| 7 | DI/O bit 6 |
| 8 | DI/O bit 7 |
| 9 | GND |

2.4.11 CANBUS Port and Pin Definition

AIR-020X offers CANBUS port and pin definition as below.

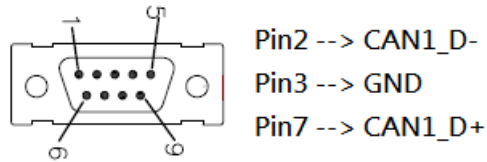

| Pin | Signal |
|-----|---------|
| 1 | Blank |
| 2 | CAN1_D- |
| 3 | GND |
| 4 | Blank |
| 5 | Blank |
| 6 | Blank |
| 7 | CAN1_D+ |
| 8 | Blank |
| 9 | Blank |

2.5 Installation

2.5.1 M.2 Installation

1. Unscrew the 4 x screws and open the bottom cover.



2. Replace the M.2 2280 M key module.(Default 128GB built-in).

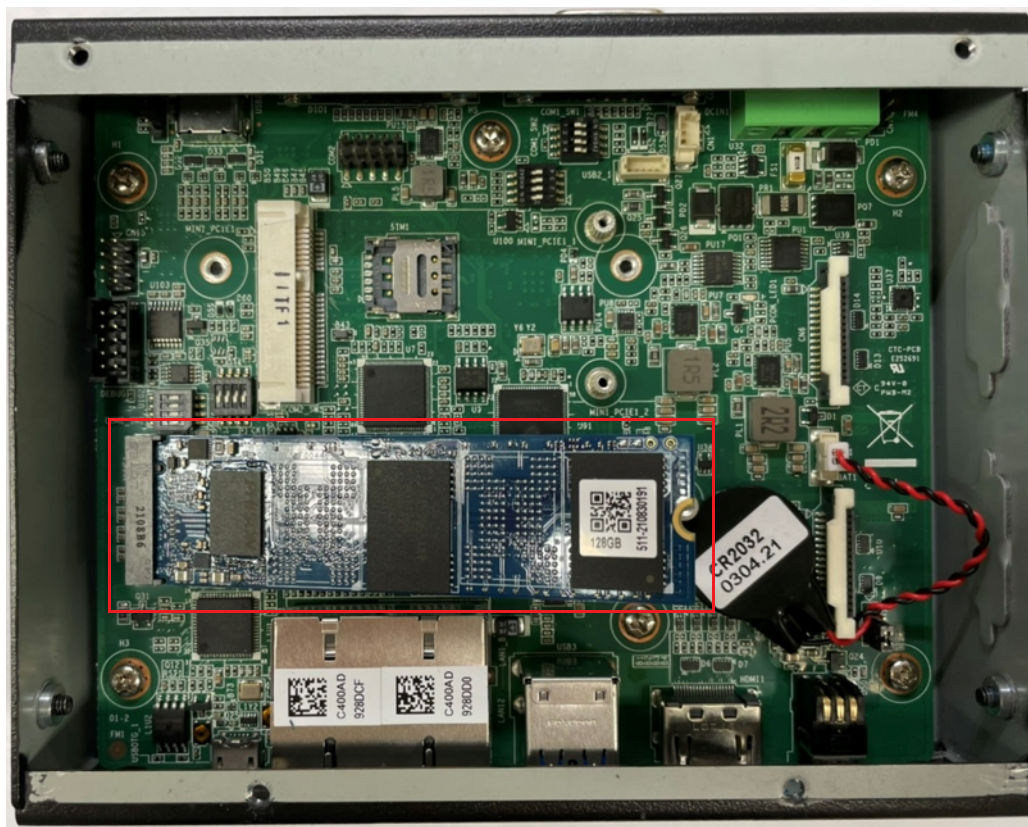

3. Screw back the bottom cover.



2.5.2 Mini PCIe Installation

1. Unscrew the 4 x screws and open the bottom cover.



2. Install full-size mPCIe module.

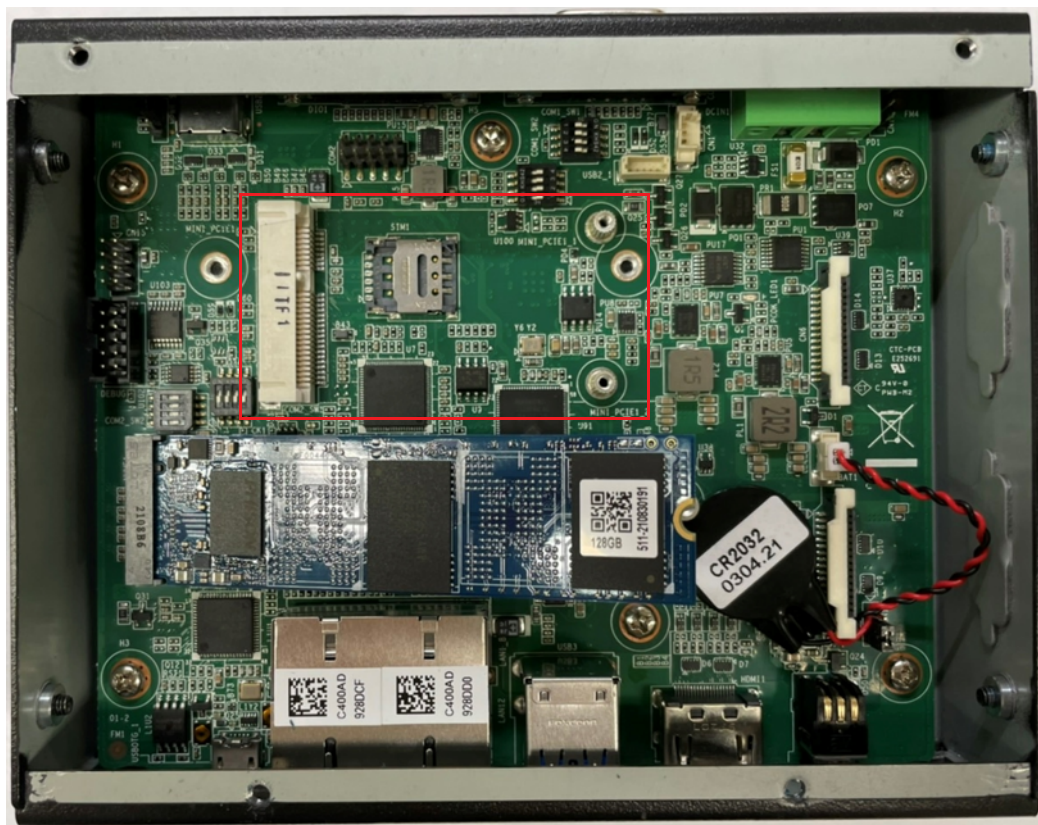

3. Screw back the bottom cover.



ADVANTECH

Enabling an Intelligent Planet

www.advantech.com

Please verify specifications before quoting. This guide is intended for reference purposes only.

All product specifications are subject to change without notice.

No part of this publication may be reproduced in any form or by any means, such as electronically, by photocopying, recording, or otherwise, without prior written permission from the publisher.

All brand and product names are trademarks or registered trademarks of their respective companies.

© Advantech Co., Ltd. 2022