

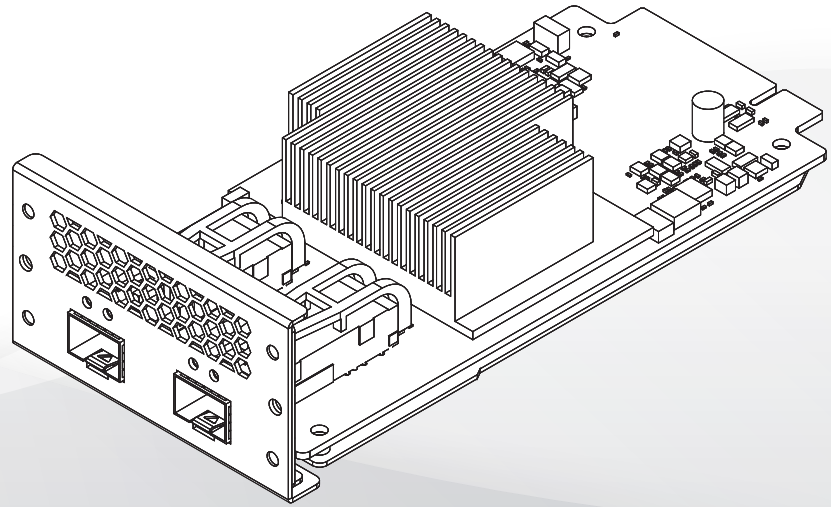

PuIM Series

PuIM-25G2SF-MLX



www.ieiworld.com

Package Contents

PuIM-25G2SF-MLX

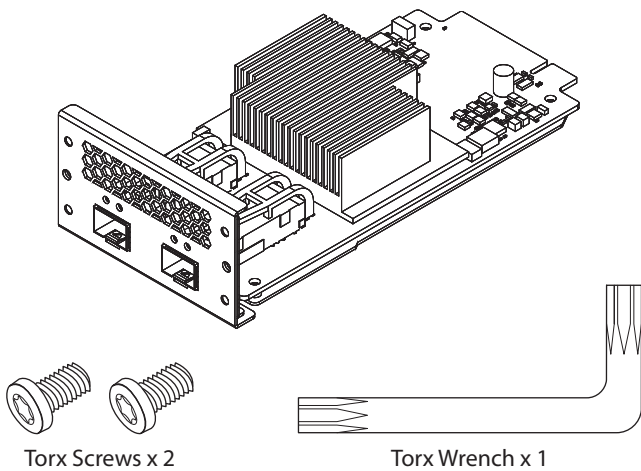

PuIM-25G2SF-MLX Block Diagram

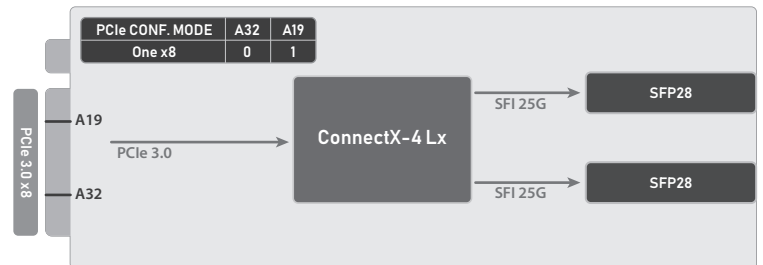

LAN LED Status

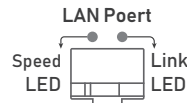

LED	State	Description
Link (Right)	Yellow	Active
Speed (Left)	Green	25 Gbps data rate
	Orange	10Gbps/1Gbps data rate

Hardware Installation

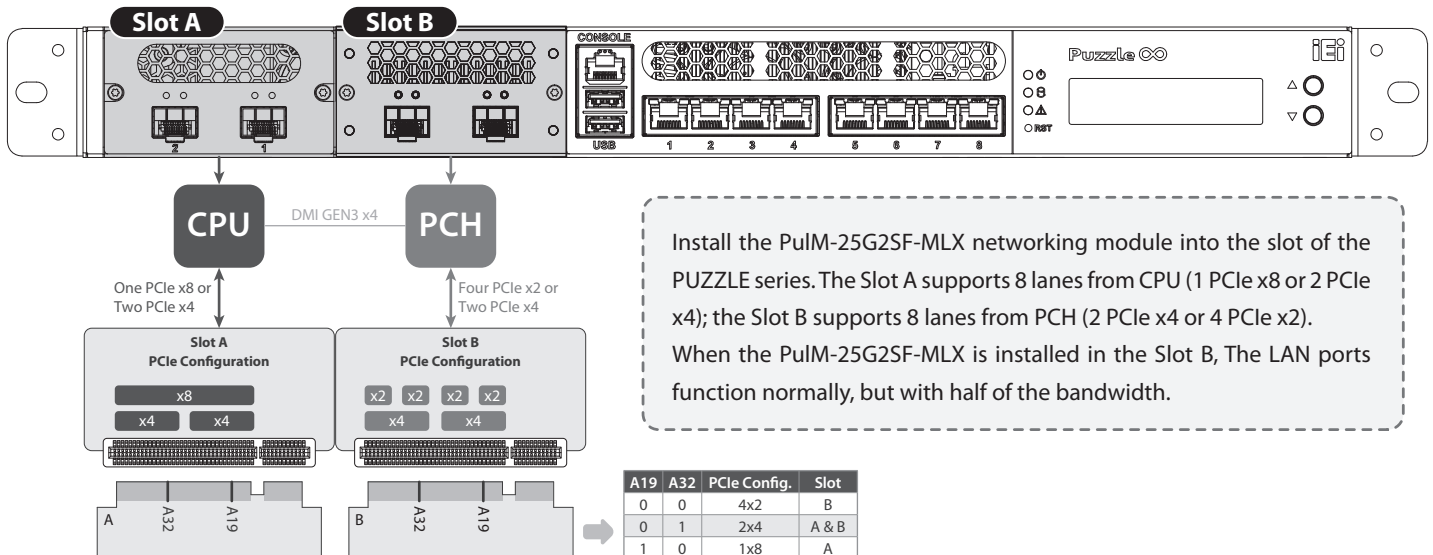

Networking Module Installation

Step 1

Use the Torx wrench to remove the two Torx screws.

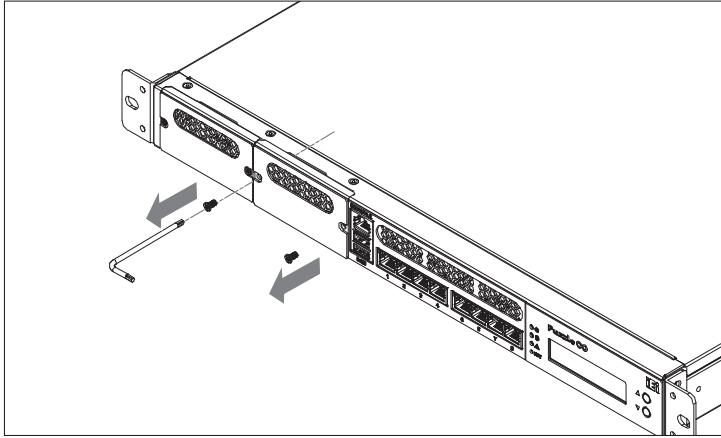

Step 2

Remove the slot cover. Save the slot cover screws.

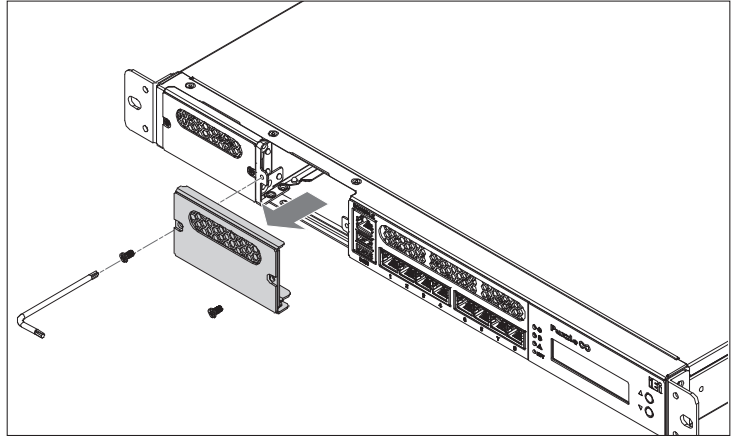

Step 3

Slide an IEI networking module into the slot until the module is seated in the slot correctly and securely.

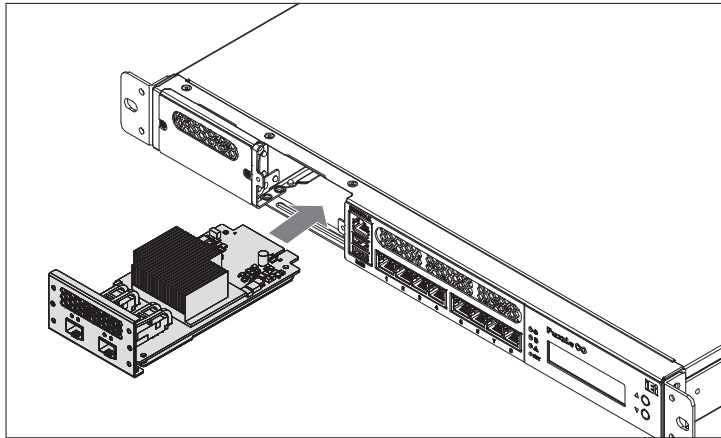

Step 4

Install the previously-removed Torx screws to secure the module to the chassis.

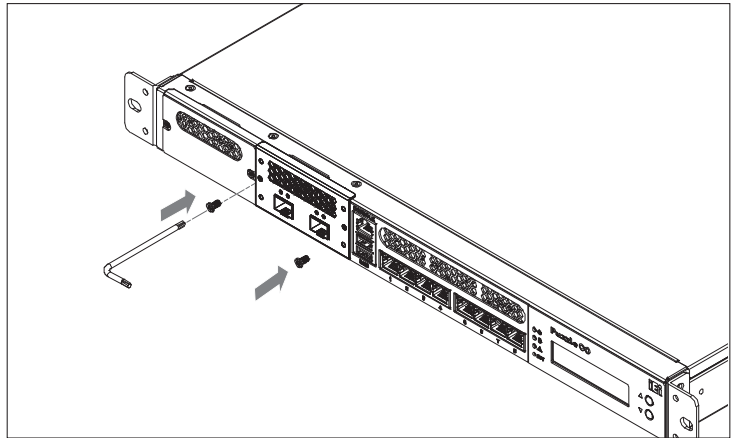

威強電工業電腦 IEI Integration Corp.

No. 29, Zhongxing Rd., Xizhi Dist., New Taipei City 221, Taiwan

TEL : +886-2-86916798 / +886-2-26902098 FAX : +886-2-66160028

sales@ieiworld.com www.ieiworld.com

