

IT32 Motherboard

3.5" SBC with Intel® 11th Generation Core i5 Processor, HDMI, LVDS,
Dual 2.5Giga Ethernet, and M.2 NGFF Interface



User Manual

Contents

Preface	3
About This User Manual	5
Chapter 1: General Information	6
1.1 Introduction.....	7
1.2 Features	7
1.3 Motherboard Specifications	8
1.4 Functional Description	10
1.5 Physical Description	11
Chapter 2: Hardware Installation	12
2.1 Motherboard Components	13
2.1.1 Component Side	13
2.1.2 I/O Side	14
2.1.3 Solder Side.....	14
2.2 Memory Module (SO-DIMM) Installation.....	15
2.3 I/O Equipment Installation	16
2.3.1 12V DC in.....	16
2.3.2 Serial COM Port	16
2.3.3 HDMI	16
2.3.4 Ethernet Interface	16
2.3.5 USB Port	16
2.3.6 Audio.....	16
2.4 Jumper Settings.....	17
2.4.1 JP2: Panel Power Selector.....	17
2.4.2 JP3: VR/Chipset Control Selector	18
2.4.3 JP4: Backlight Power Selector	18
2.4.4 JP5: PWM/DC Mode Control Selector	18
2.5 Mainboard Connectors	19
2.5.1 External I/O Side Connectors.....	19
2.5.2 Internal I/O Side Connectors.....	21
Chapter 3: Driver Installation	28
3.1 Chipset Driver	29
3.2 Graphic Driver.....	32
3.3 Management Engine (ME)	34
3.4 Audio Driver	36
3.5 Ethernet Driver.....	38
3.6 DTT Driver	40
3.7 GNA Driver.....	42
3.8 Serial IO Driver.....	43

3.9 Resistive Touch Driver for Windows 11 System	46
3.10 Thermal Control AP	50
Chapter 4: INSYDE H20 BIOS Setup.....	57
4.1 How and When to Use BIOS Setup	58
4.2 BIOS Functions	59
4.2.1 Main Menu	59
4.2.2 Advanced	60
4.2.3 Security	79
4.2.4 Power	80
4.2.5 Boot.....	81
4.2.6 Exit	84
4.3 Using Recovery Wizard to Restore Computer	85
4.4 How to Enable Watchdog.....	86
Chapter 5: Technical Support	87
5.1 Drivers	88
5.2 Software Development Kit (SDK).....	88

Preface

Copyright Notice

No part of this document may be reproduced, copied, translated, or transmitted in any form or by any means, electronic or mechanical, for any purpose, without the prior written permission of the original manufacturer.

Trademark Acknowledgement

Brand and product names are trademarks or registered trademarks of their respective owners.

Disclaimer

We reserve the right to make changes, without notice, to any product, including circuits and/or software described or contained in this manual in order to improve design and/or performance. We assume no responsibility or liability for the use of the described product(s), conveys no license or title under any patent, copyright, or masks work rights to these products, and makes no representations or warranties that these products are free from patent, copyright, or mask work right infringement, unless otherwise specified. Applications that are described in this manual are for illustration purposes only. We make no representation or warranty that such application will be suitable for the specified use without further testing or modification.

Warranty

We warrant that each of its products will be free from material and workmanship defects for a period of one year from the invoice date. (Standard is one-year, extended warranty will need to discuss with our sales representatives. If the customer discovers a defect, we will, at its option, repair or replace the defective product at no charge to the customer, provided it is returned during the warranty period of one year, with transportation charges prepaid. The returned product must be properly packaged in its original packaging to obtain warranty service.

If the serial number and the product shipping data differ by over 30 days, the in- warranty service will be made according to the shipping date. In the serial numbers the third and fourth two digits give the year of manufacture, and the fifth digit means the month (e. g., with A for October, B for November and C for December).

For example, the serial number 1W16Axxxxxxx means October of year 2016.

Packing List

Before using this Motherboard, please make sure that all the items listed below are present in your package:

- IT32 Motherboard
- User Manual

If any of these items are missing or damaged, contact your distributor or sales representative immediately.

Customer Service

We provide a service guide as below for any problem by the following steps:

First, contact your distributor, sales representative, or our customer service center for technical support if you need additional assistance.

You need to prepare the following information before you call:

- Product serial number
- Peripheral attachments
- Software (OS, version, application software, etc.)
- Detailed problem description
- The exact wording of any error messages

In addition, free technical support is available from our engineers every business day. We are always ready to give advice on application requirements or specific information on the installation and operation of any of our products. Please do not hesitate to call or e-mail us.

Advisory Conventions

Four types of advisories are used throughout the user manual to provide helpful information or to alert you to the potential for hardware damage or personal injury. These are Notes, Important, Cautions, and Warnings. The following is an example of each type of advisory.

**NOTE:**

A note is used to emphasize helpful information

**IMPORTANT:**

An important note indicates information that is important for you to know.

**CAUTION**

A Caution alert indicates potential damage to hardware and explains how to avoid the potential problem.

**WARNING!**

An Electrical Shock Warning indicates the potential harm from electrical hazards and how to avoid the potential problem.

Safety Precautions



CAUTION

Always ground yourself to remove any static charge before touching the CPU card. Modern electronic devices are very sensitive to static electric charges. As a safety precaution, use a grounding wrist strap at all times. Place all electronic components in a static-dissipative surface or static-shielded bag when they are not in the chassis.

Safety and Warranty

1. Please read these safety instructions carefully.
2. Please keep this user manual for later reference.
3. Please disconnect this equipment from any AC outlet before cleaning. Do not use liquid or spray detergents for cleaning. Use a damp cloth.
4. For pluggable equipment, the power outlet must be installed near the equipment and must be easily accessible.
5. Keep this equipment away from humidity.
6. Put this equipment on a reliable surface during installation. Dropping it or letting it fall could cause damage.
7. Make sure the voltage of the power source is correct before connecting the equipment to the power outlet.
8. Position the power cord so that people cannot step on it. Do not place anything over the power cord.
9. All cautions and warnings on the equipment should be noted.
10. If the equipment is not used for a long time, disconnect it from the power source to avoid damage by transient over-voltage.
11. If any of the following situations arises, get the equipment checked by service personnel:
 - A. The power cord or plug is damaged.
 - B. Liquid has penetrated into the equipment.
 - C. The equipment has been exposed to moisture.
 - D. The equipment does not work well, or you cannot get it to work according to the user's manual.
 - E. The equipment has been dropped and damaged.
 - F. The equipment has obvious signs of breakage.

About This User Manual

This User Manual provides information about using the IT32 Motherboard. The documentation set for the IT32 Motherboard provides information for specific user needs, and includes:

- **IT32 Motherboard User Manual** – contains detailed description on how to use the motherboard, its components and features.



NOTE:

Some pictures in this guide are samples and can differ from actual product.

Chapter 1: General Information

This chapter includes the IT32 Motherboard background information.

- 1.1 Introduction
 - 1.2 Features
 - 1.3 Motherboard Specifications
 - 1.4 Functional Description
 - 1.5 Physical Description
-

1.1 Introduction

Thank you for choosing the IT32 Motherboard. This motherboard can be integrated with Intel® Core i5-1135G7 4 Core 2.4GHz (up to 4.2GHz) which offers a high-performance computing platform with low power consumption. The new motherboard supports 260-pin SO-DIMM DDR4 at speeds of 3200 MHz, up to 32GB. This motherboard supports Intel® Core™ processor: Intel® 11th Generation Core™ based on 64-bit, multi-core processor and built on 10-nanometer processor technology.

In peripheral connectivity, IT32 Motherboard features one M.2 Key-E with PCIe x1, USB 2.0 for wireless, one M.2 Key-M, 2242/2280 with SATAIII or PCIe SSD, one Serial ATA III (6Gb/s) connectors, one RS232/422/485 (Default RS232) DB9 connector, three serial ports (internal connectors), 2 super-speed USB 3.2 Gen2x1 (10Gbps) connectors and four hi-speed USB 2.0 connectors (four pin headers). Additionally, IT32 SBC features build-in a 12V DC in power adapter.

Abundant I/O connectors and expandability makes IT32 Motherboard to be the right fit in the majority of industrial computer applications such as machine vision and control, gaming, POS, KIOSK systems, industrial automation, and others. Powerful processor in 3.5" form-factor meets the demanding performance requirements of modern industrial applications.

1.2 Features

IT32 Motherboard features:

- 3.5" Form Factor (146mm x 102mm)
- Intel® 11th. Tiger Lake Core i5-1135G7 processor
- Intel® Iris® Xe Graphics supports DirectX 12.1 and OpenGL 4.6
- 1 x SODIMM, DDR4 3200MHz, support up to 32GB
- Integrated Dual Gigabit Ethernet
- 1 x M.2 (Key E) with PCIe x1+USB 2.0 for wireless
- 1 x M.2 (Key M, 2242/2280) with PCIe or SATAIII for SSD
- 2 x USB 3.2 Gen2x1
- 1 x SATA III

1.3 Motherboard Specifications

		Model Name
		IT32
System Specifications	CPU	Intel Core i5-1135G7 2.4GHz (up to 4.2GHz)
	Chipset	Intel® SoC Integrated
	System Memory	1 x Non ECC SO-DIMM, DDR4 3200 MHz, Max. 32GB
	Storage	1 x M.2 M-Key 2242 SATA SSD, Max. 512GB or 1 x M.2 M-Key 2280 NVMe SSD, Max. 4TB 1 x SATA III, Max. 2TB (Optional)
	BIOS	Insyde System BIOS
	Graphic	Intel® Iris® Xe Graphics
	Audio	Realtek HD Audio Codec
	LAN	2 x Intel® Ethernet controller
	USB	2 x USB 3.2 Gen2x1 (10Gbps)
Display Specifications	Display Interface	Supports DirectX 12.1 and OpenGL 4.6
		HDMI supports HDMI 2.0 , Max resolution up to 4096x2304 @60Hz
		eDp: supports eDP 1.4a , Max resolution up to 1920 x 1200@60Hz
I/O Ports Specification	External I/O	2 x USB 3.2 Gen2x1 (10Gbps) 2 x RJ-45 for 2.5Giga LAN with LED 1 x HDMI 2.0 1 x RS232/422/485 (Default RS232) 1 x (+12V) Power Input with 2.5φ DC jack
	Internal I/O	3 x RS232 Serial Console to 2x5 Pin Header 1 x Power 6P Wafer 1 x SPK R / SPK L 2 x USB 2.0 Pin Wafer (4 Ports) 1 x Digital I/O (12-bit GPIO) / 14-pin (2x7) 1 x CPU FAN Connector 1 x SATA III Connectors 1 x SATA Power Connector 1 x +12V for external power (Yellow) / 2-pin 1 x +5V for external power (Red) / 2-pin 1 x +3.3V for external power (Blue) / 2-pin 1 x RTC battery wafer 1 x Panel inverter / 7-pin 1 x LVDS / 40-pin(2x20) DF-13 connector 1 x eDP / 30-pin(2x15) DF-13 connector 1 x Brightness control /3-pin 1 x 3pin(1x3) for Digital panel backlight brightness control 1 x 3pin(1x3) VR/Software brightness switch jumper 1 x 3pin(1x3) PWM/DC brightness switch jumper 1 x 3pin(1x3) 3.3V/5V PWM Level switch jumper 1 x Front panel / 10-pin(2x5) 1 x Audio (Mic-in / Line-in / Line-out) / 12-pin(2x6)
	Expansions	1 x M.2 (Key E) with PCIe x1+USB 2.0 for wireless

		Model Name
		IT32
Security Mechanical Specifications	Slot	1 x M.2 (Key M, 2242/2280) with SATAIII SSD or PCIe Gen3 x4 SSD
	TPM	TPM 2.0
	Dimensions	146 (W)x 102(L) mm
Environment Considerations	Operating Temp.	0°C ~ 60°C
	Storage Temp.	-40°C ~ 70°C
	Operating Humidity	10% ~ 95%, non-condensing
Power Management	Power Input	+12V Power Input
	Power Consumption	Maximum 80W
Packing List	Standard	IT32 Single Board Computer IT32 Manual-

1.4 Functional Description

Function block

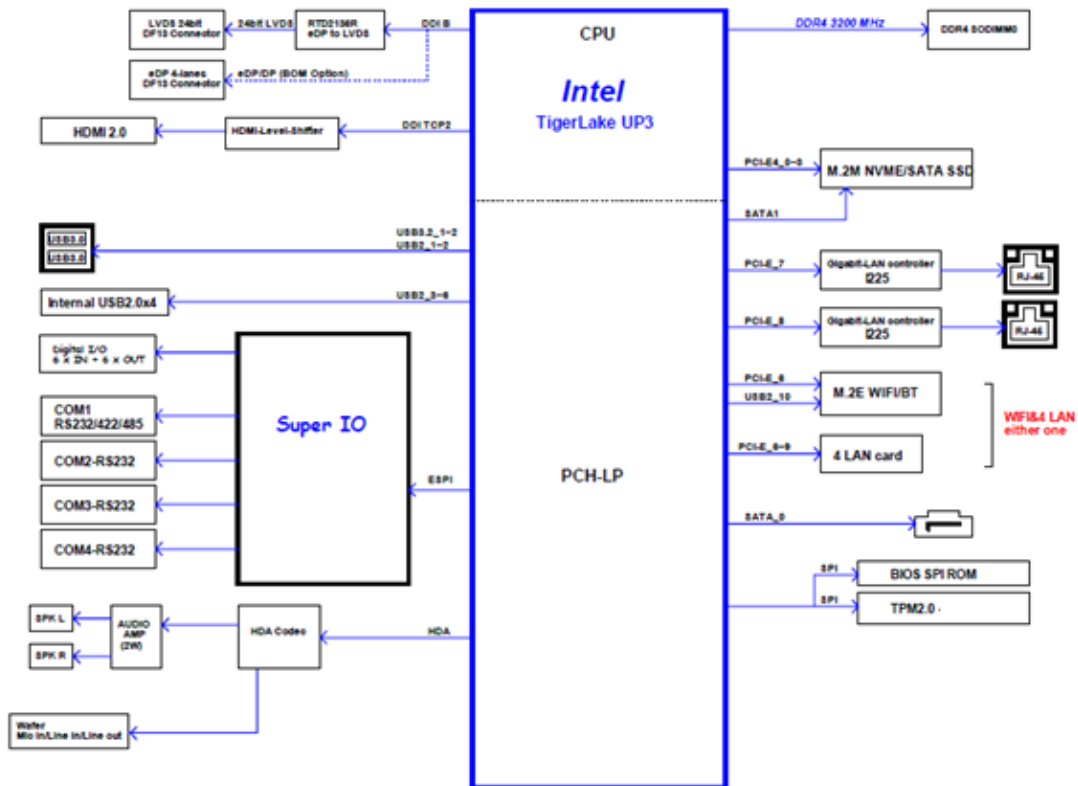

1.5 Physical Description

Board Dimensions

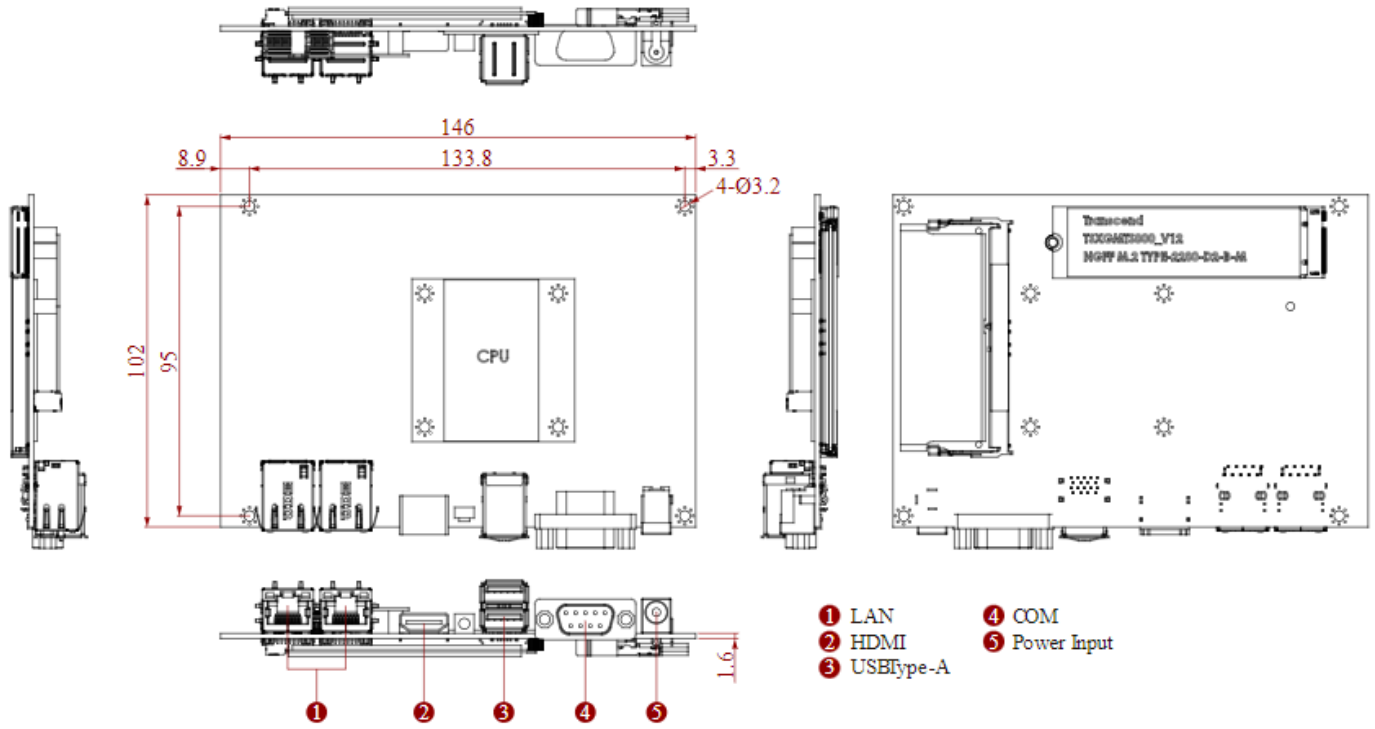

Chapter 2: Hardware Installation

This chapter provides information on how to use jumpers and connectors on the IT32 motherboard.

- 2.1 Motherboard Components
 - 2.2 Memory Module Installation
 - 2.3 I/O Equipment Installation
 - 2.4 Jumper Settings
 - 2.5 Motherboard Connectors
-

This chapter provides information on how to use jumpers and connectors on the IT32 Motherboard. Be cautious while working with these modules. Carefully read the content of this chapter in order to avoid any damages.

2.1 Motherboard Components

2.1.1 Component Side

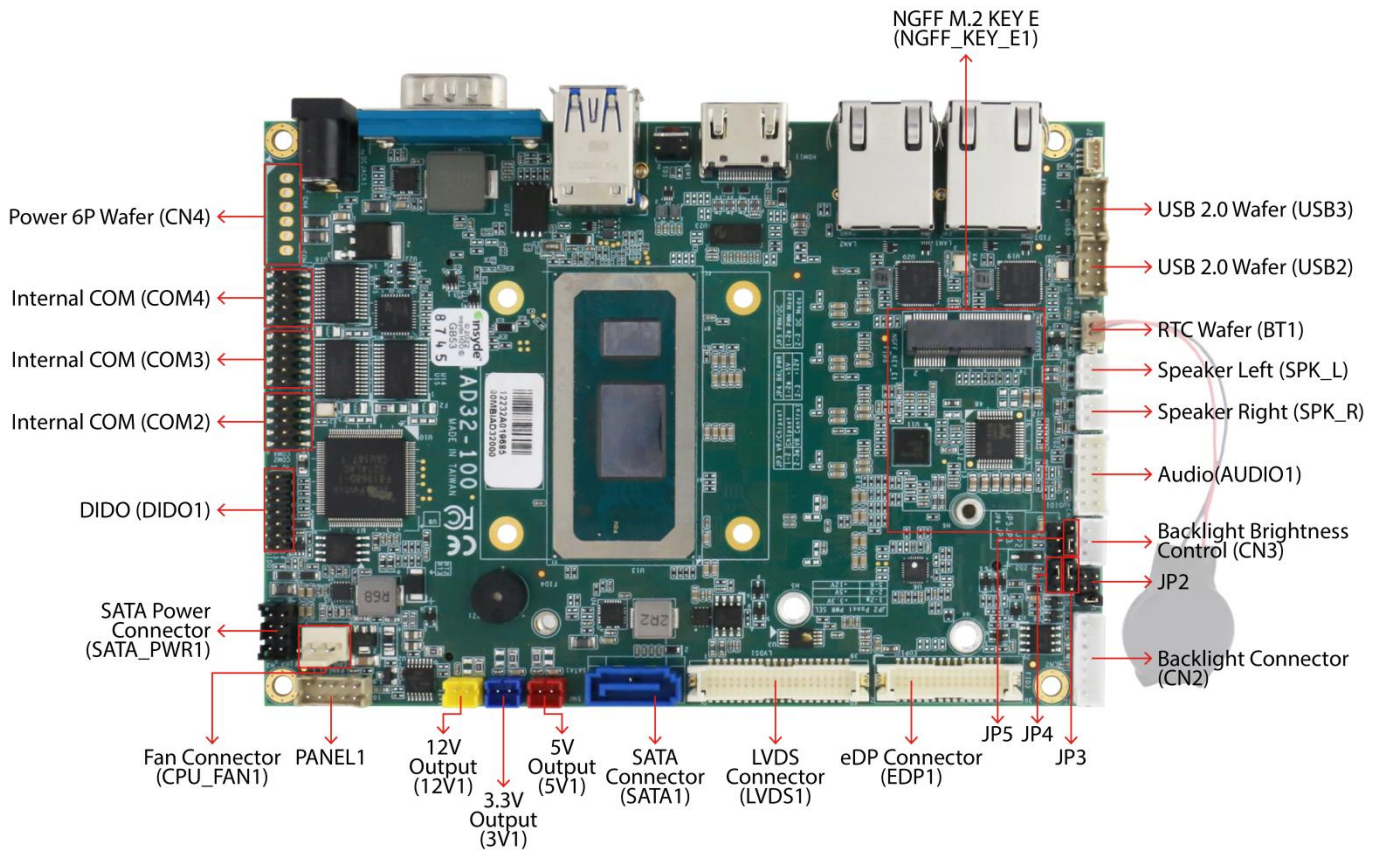

2.1.2 I/O Side

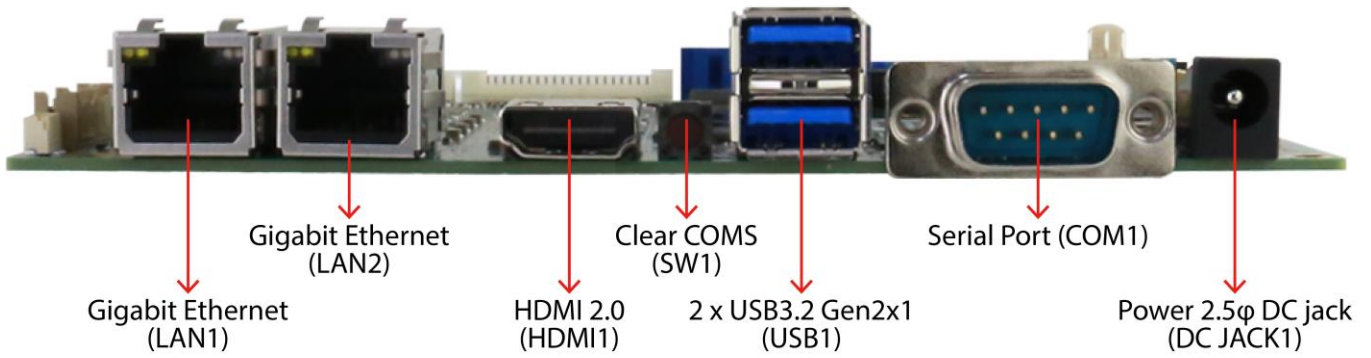

2.1.3 Solder Side

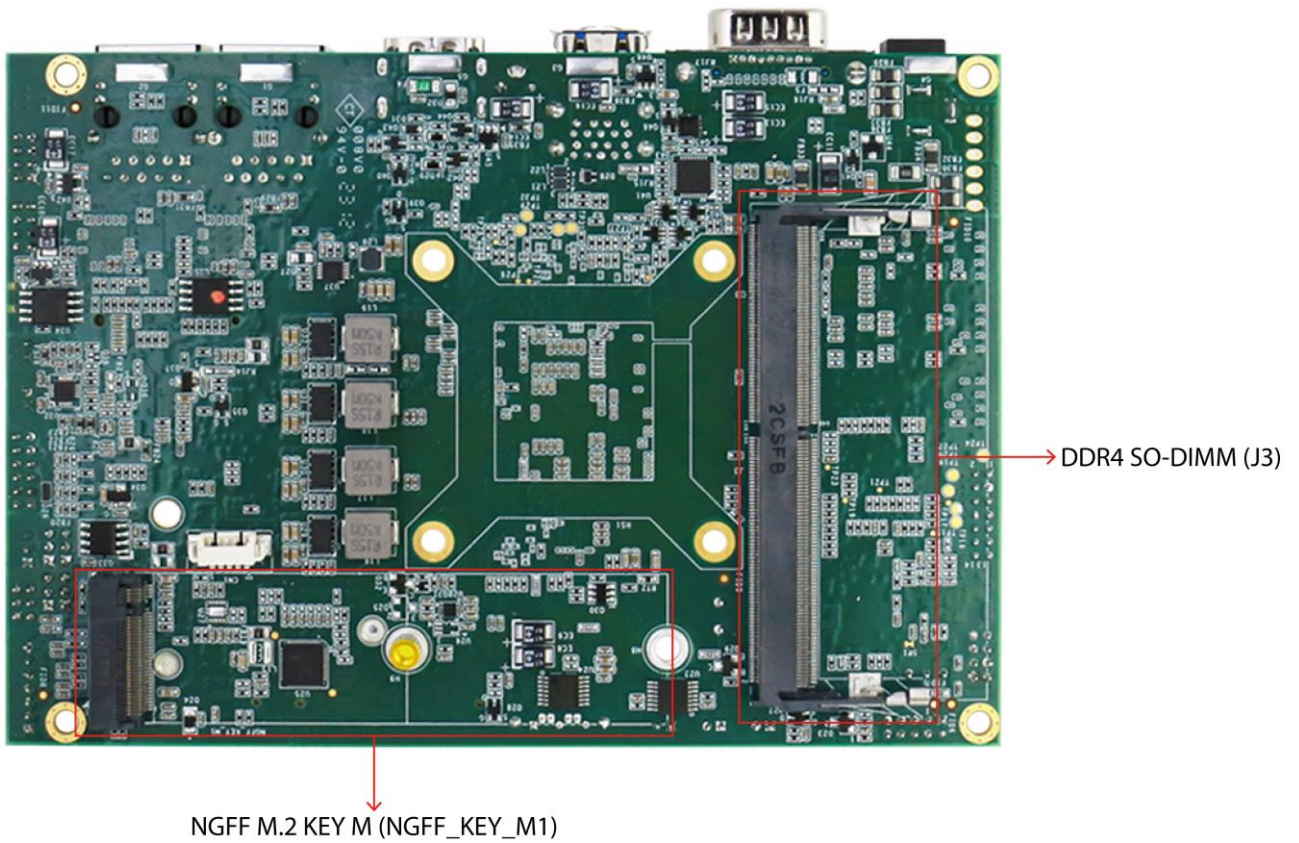

2.2 Memory Module (SO-DIMM) Installation

The IT32 SBC Motherboard has one 260-pin SODIMM slot. The socket supports DDR4. When installing the memory unit, please follow the steps below:

1. Firmly insert the SO-DIMM at an angle of about 30-degree into the slot. Align the SO-DIMM with the slot until it is fully inserted. The notch on the SO-DIMM should match the break on the slot.
2. Press downwards on SO-DIMM until the retaining clips at both ends fully snap closed and the SO-DIMM is properly seated.

Pull the tabs away with your thumbs, bracing your forefingers against the rails. The memory module will be released. Then raise the memory module to a vertical position.

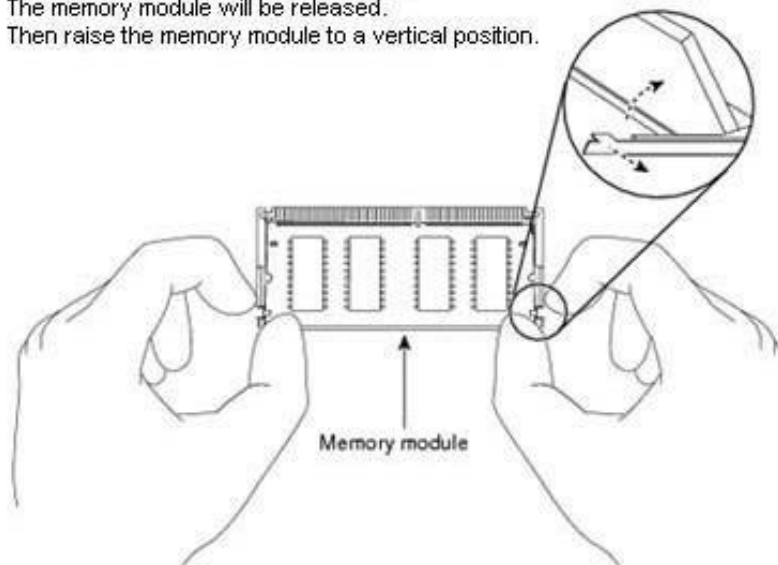

CAUTION

The SO-DIMM only fits in one correct orientation. It will cause permanent damage to the development board and the SO-DIMM if the SO-DIMM is forced into the slot at the incorrect orientation.

2.3 I/O Equipment Installation

2.3.1 12V DC in

The IT32 Motherboard allows plugging 12V DC-IN jack on the board without another power module converter under power consumption by Intel® 11th Generation Core i5 Processor.

2.3.2 Serial COM Port

One RS-232 connectors build-in the rear I/O can optional supports RS-422/ 485. You can change serial COM port setting through BIOS. Three RS232 (2x5, 10pin) wafers build-in the internal I/O.

*When an optional touch-screen ordered with PPC, serial COM port can be connected to a serial or an optional touch-screen.

2.3.3 HDMI

The Motherboard has one HDMI port that can be connected to an external LCD monitor. Use HDMI cable to connect to an external LCD monitor, and connect the power cable to the outlet. The HDMI connector is a standard 19-pin HDMI connector.

2.3.4 Ethernet Interface

The Motherboard is equipped with Intel® Gigabit-LAN Controller. It is supported by major network operating systems. The Ethernet ports provide two standard RJ-45 jacks.

2.3.5 USB Port

Six USB devices (four with pin headers) may be connected to the system though an adapter cable. Various adapters may come with USB ports. USB usually connect the external system to the system. The USB ports support hot plug-in connection. Whatever, you should install the device driver before you use the device.

2.3.6 Audio

The High-Definition Audio Codec capabilities are provided by a Realtek chipset supporting digital audio outputs. The audio interface includes three jacks: line-in, line-out and mic-in.

2.4 Jumper Settings

This section explains how to set jumpers for correct configuration of the motherboard.



NOTE:

A pair of needle nose pliers may be helpful when working with jumpers. If you have any doubts about the best hardware configuration for your application, contact your local distributor or sales representative before you make any changes. Generally, you simply need a standard cable to make most connections.

The jumper setting diagram is shown below. When the jumper cap is placed on both pins, the jumper is SHORT. The illustration below shows a 3-pin jumper; pins 1 and 2 are short. If you remove the jumper cap, the jumper is OPEN.

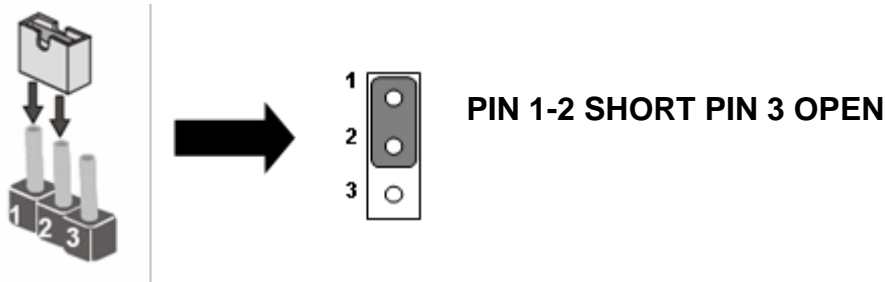

CAUTION

To avoid damaging the module, always turn off the power supply before setting jumpers or clearing CMOS.

Label	Function	Note
Jumpers		
JP2	Panel Power Selector	2x3 header, pitch 2.0mm
JP3	VR/Chipset Control Selector	1x3 header, pitch 2.0mm
JP4	Backlight Power Selector	1x3 header, pitch 2.0mm
JP5	PWM/DC Mode Control Selector	1x3 header, pitch 2.0mm

2.4.1 JP2: Panel Power Selector

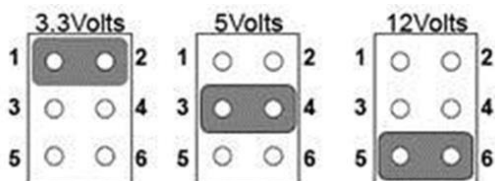

Pin No	Signal Name
1-2 (Default)	+3.3V
3-4	+5V
5-6	+12V

2.4.2 JP3: VR/Chipset Control Selector

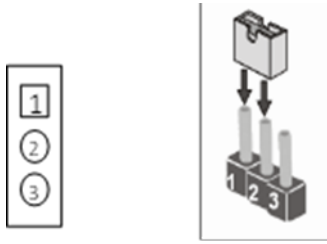

Pin No	Signal Name
1-2	Chipset
2-3(Default)	VR Control

2.4.3 JP4: Backlight Power Selector

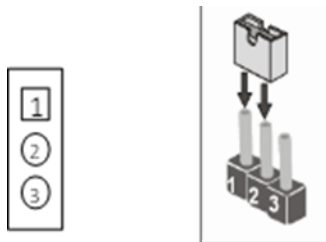

Pin No	Signal Name
1-2 (Default)	+5V
2-3	+12V

2.4.4 JP5: PWM/DC Mode Control Selector

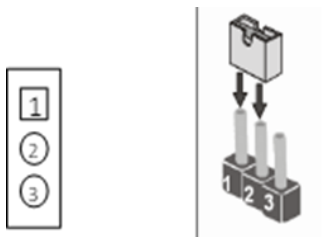

Pin No	Signal Name
1-2 (Default)	PWM Mode
2-3	DC Mode

2.5 Mainboard Connectors

2.5.1 External I/O Side Connectors

Label	Function	Note
Connector		
DCJACK1	DC Jack	2.5 ϕ DC Jack
COM1	Serial port (RS232/422/485)	D-Sub9 (Male)
USB1	2 x USB 3.2 Gen2 x1 (10Gbps)	USB Type A
HDMI1	HDMI 2.0 Signal	HDMI Type A
LAN1, LAN2	2.5Gigabit Ethernet	RJ45+LED
SW1	Clear CMOS, Reset	Button

2.5.1.1 DCJACK1: Power 2.5 ϕ DC Jack Connector

The DC power input for the IT32 Motherboard allows a voltage input of 12V DC.

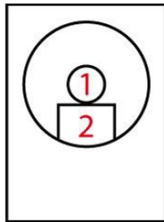

Pin №	Signal Name	Pin №	Signal Name
1	12VDC	2	GND

2.5.1.2 COM1: D-Sub9 (Male)

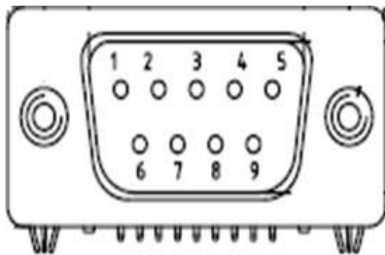

Pin №	RS232	RS422	RS485
1	DCD	TxD-	D-
2	RXD	TxD+	D+
3	TXD	RxD+	NC
4	DTR	RxD-	NC
5	GND	GND	GND
6	DSR	NC	NC
7	TRTD	NC	NC
8	CTS	NC	NC
9	RI	NC	NC

Note: Refer to BIOS to change serial COM port settings.

2.5.1.3 USB1, USB2: USB 3.2

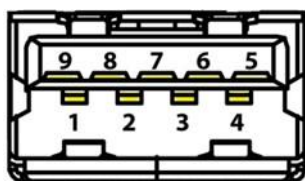

Pin №	Signal Name	Pin №	Signal Name
1	+5V	2	USB_D-
3	USB_D+	4	GND
5	STDA_SSRX-	6	STDA_SSRX+
7	GND_DRAIN	8	STDA_SSTX-
9	STDA_SSTX+		

2.5.1.4 HDMI1 : HDMI 2.0 Type A

Use HDMI connector to connect the IT32 to an external monitor.

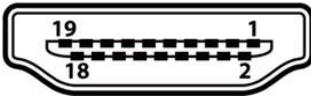

Pin №	Signal Name	Pin №	Signal Name
1	HDMI_DET	2	NV
3	HDMI_D2P	4	GND
5	HDMI_D2M	6	HDMI_D1P
7	GND	8	HDMI_D1M
9	HDMI_D0P	10	GND
11	HDMI_D0M	12	HDMI_CLKP
13	GND	14	HDMI_CLKM
15	HDMI_CEC_OUT	16	GND
17	DDC_CLOCK	18	DDC_DATA
19	+5V	20	GND

2.5.1.5 LAN1, LAN2: 2.5Gigabit Ethernet

IT32 has two Ethernet connectors located on the front. Ethernet ports provide a standard RJ45 jack connector with LED indicators on the front side to show its Active/ Link status and Speed status.

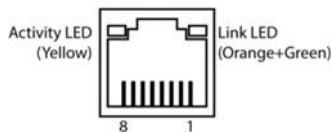

Pin №	Signal Name	Pin №	Signal Name
1	TX1+	2	TX1-
3	TX2+	4	TX2-
5	TX3+	6	TX3-
7	TX4+	8	TX4-

2.5.2 Internal I/O Side Connectors

Label	Function	Note
Connectors		
CN2	Backlight Connector	7p P:2.0mm DIP 180°
CN3	Backlight Brightness Control	3p P:2.0mm DIP 180°
CN4	Power 6P Wafer	Wafer 6p DIP
USB2	USB2.0 Wafer	2*4p P:2.0mm DIP 180°
USB3	USB2.0 Wafer	2*4p P:2.0mm DIP 180°
BT1	RTC Battery Wafer	2P wafer, pitch 1.25 mm
SPK_L	Speaker Left	Wafer/2p P:2.0mm SIP 180°
SPK_R	Speaker Right	Wafer/2p P:2.0mm SIP 180°
AUDIO1	Audio	2x6 wafer, pitch 2.0mm
EDP1	eDP Connector	DF13 2*15p P:1.25mm SMD 180° White color
LVDS1	LVDS Connector	2*20p P:1.25mm SMD 180° White color
SATA1,	SATA Connector	WATM-07ABN4A2B8UW
SATA_PWR1	SATA Power Connector	2*4p P:2.0mm DIP 180°
5V1	5V Power Output Wafer	2p P:2.0mm DIP 180°, red color (5V Output)
3V1	3.3V Power Output Wafer	2p P:2.0mm DIP 180°, blue color (3.3V Output)
12V1	12V Power Output Wafer	2p P:2.0mm DIP 180°, yellow color (12V Output)
PANEL 1	Front Panel Pin Header	2*5p P:2.0mm SMD 180°
CPU_FAN1	CPU Fan	3P wafer, pitch 2.54mm
DIDO1	Digital Input / Digital Output	2x7 wafer, pitch 2.0mm
COM2	Internal COM Port (RS232)	2*5p P:2.0mm SMD 180°
COM3	Internal COM Port (RS232)	2*5p P:2.0mm SMD 180°
COM4	Internal COM Port (RS232)	2*5p P:2.0mm SMD 180°
NGFF_KEY_E1	NGFF M.2 KEY E Connector	NXSE0-S6705-TP50
NGFF_KEY_M1	NGFF M.2 KEY M Connector	NGFF M.2 KEY M Connector
J3	DDR4 SO- DIMM slot	ASAAC26-J2SB0-7H 5.2mm STD

2.5.2.1 CN2: Backlight Connector

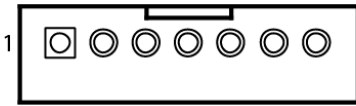

Pin №	Signal Name	Pin №	Signal Name
1	+BKLPWR_R	2	+BKLPWR_R
3	+BKLPWR_R	4	GND
5	BRIGHT	6	GND
7	BLON_5V		

Note: Please refer to JP1 settings to select Power Rating.

2.5.2.2 CN3: Backlight Brightness Control

VR Knob

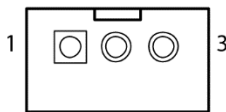

Pin №	Signal Name	Pin №	Signal Name
1	+V5S	2	VRD_ADC
3	GND		

2.5.2.3 CN4: Power 6P Wafer



Pin №	Signal Name	Pin №	Signal Name
1	+12V	2	+12V
3	+12V	4	DC_GND
5	DC_GND	6	DC_GND

2.5.2.4 USB2, USB3: USB2.0 Wafer

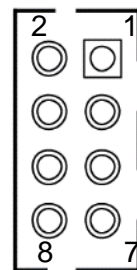
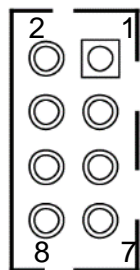

Pin №	Signal Name	Pin №	Signal Name
1	USB_VCC	2	USB_VCC
3	USB_DN	4	USB_DN
5	USB_DP	6	USB_DP
7	GND	8	GND

Pin №	Signal Name	Pin №	Signal Name
1	USB_VCC	2	USB_VCC
3	USB_DN	4	USB_DN
5	USB_DP	6	USB_DP
7	GND	8	GND

2.5.2.5 BT1: RTC Battery Connector

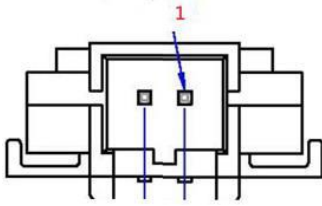

Pin №	Signal Name	Pin №	Signal Name
1	GND	2	+3.3V

2.5.2.6 SPK_L, SPK_R: Speaker Out

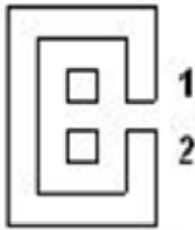

Pin №	Signal Name	Pin №	Signal Name
1	LOUT+	2	LOUT-

2.5.2.7 AUDIO1: Audio

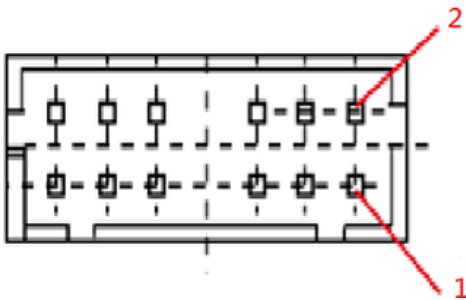

Pin №	Signal Name	Pin №	Signal Name
1	LINE_OUT_R	2	LINE_OUT_L
3	+5V	4	GND
5	LINE_IN_R	6	LINE_IN_L
7	MIC_R	8	MIC_L
9	GND	10	LINE_OUT_JACK
11	MIC_JACK DET	12	LINE_IN_JACK

2.5.2.8 EDP1: eDP Connector

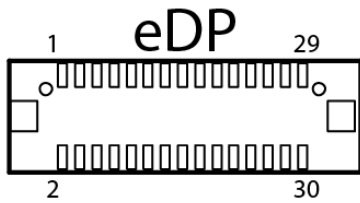

Pin №	Signal Name	Pin №	Signal Name
1	EMB_AUXN	2	NC
3	EMB_AUXP	4	NC
5	GND	6	GND
7	DP_TXN3_C	8	+VCC_EDP_BKLT
9	DP_TXP3_C	10	+VCC_EDP_BKLT
11	GND	12	EPD_HPD
13	DP_TXN2_C	14	GND
15	DP_TXP2_C	16	GND
17	GND	18	GND
19	DP_TXN1_C	20	GND
21	DP_TXP1_C	22	LCDVDD
23	GND	24	LCDVDD
25	DP_TXN0_C	26	LCDVDD
27	DP_TXP0_C	28	LCDVDD
29	GND	30	+VCC_EDP_BKLT

2.5.2.9 LVDS1: LVDS Connector



Pin №	Signal Name	Pin №	Signal Name
1	LCDVDD	2	LVDS0_TX0_N
3	LCDVDD	4	LVDS0_TX0_P
5	LCDVDD	6	LVDS0_TX1_N
7	GND	8	LVDS0_TX1_P
9	GND	10	LVDS0_TX2_N
11	GND	12	LVDS0_TX2_P
13	GND	14	LVDS0_CLK_N
15	GND	16	LVDS0_CLK_P
17	GND	18	LVDS0_TX3_N
19	GND	20	LVDS0_TX3_P
21	GND	22	LVDS1_TX0_N
23	GND	24	LVDS1_TX0_P
25	GND	26	LVDS1_TX1_N
27	GND	28	LVDS1_TX1_P
29	GND	30	LVDS1_TX2_N
31	GND	32	LVDS1_TX2_P
33	GND	34	LVDS1_CLK_N
35	GND	36	LVDS1_CLK_P
37	GND	38	LVDS1_TX3_N
39	GND	40	LVDS1_TX3_P

2.5.2.10 SATA1: SATA Connector

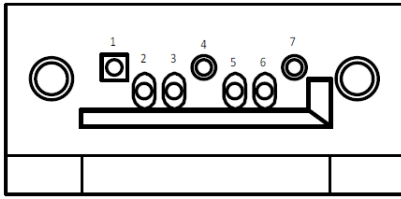

Pin №	Signal Name	Pin №	Signal Name
1	GND	2	SATA_TXP
3	SATA_TXN	4	GND
5	SATA_RXN	6	SATA_RXP
7	GND		

2.5.2.11 SATA_PWR1: SATA Power Connector

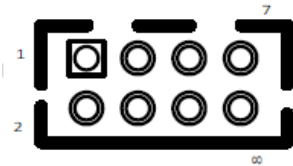

Pin №	Signal Name	Pin №	Signal Name
1	+12V	2	+12V
3	GND	4	GND
5	GND	6	GND
7	+5V	8	+5V

2.5.2.12 5V1: 5V Power Output

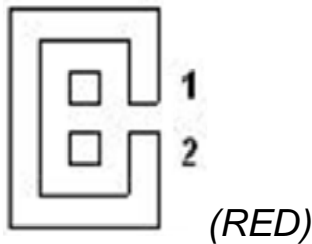

Pin №	Signal Name	Pin №	Signal Name
1	+5V	2	GND

2.5.2.13 3V1: 3.3V Power Output

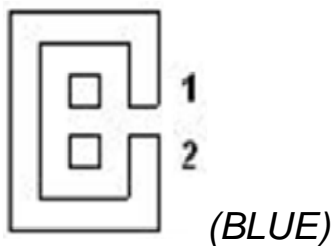

Pin №	Signal Name	Pin №	Signal Name
1	+3.3V	2	GND

2.5.2.14 12V1: 12V Power Output

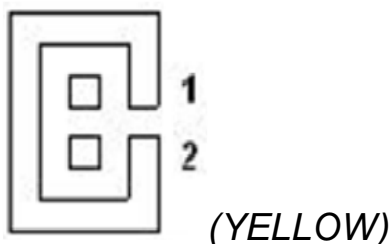

Pin №	Signal Name	Pin №	Signal Name
1	+12V	2	GND

2.5.2.15 PANEL1: Front Panel Pin Header

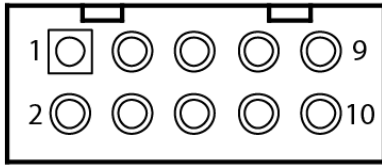

Pin №	Signal Name	Pin №	Signal Name
1	+5V	2	+3.3V
3	GND	4	SATA_LED#
5	PWRBTN#	6	GND
7	Backlight_ADJ+	8	FP_RST_N
9	Backlight_ADJ-	10	+5V

2.5.2.16 CPU_FAN1: Fan Connector



Pin 1 GND
Pin 2 +12V
Pin 3 SENSE

Pin №	Signal Name	Pin №	Signal Name
1	GND	2	+12V
3	SENSE		

2.5.2.17 DIO1: Digital Input / Digital Output

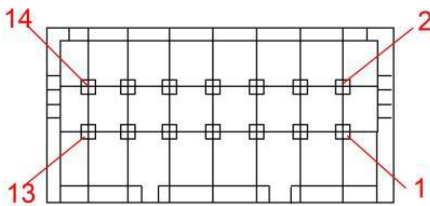

Pin №	Signal Name	Pin №	Signal Name
1	GND	2	DIO_5V
3	DOUT3	4	DOUT1
5	DOUT2	6	DOUT0
7	DINT3	8	DINT1
9	DINT2	10	DINT0
11	GPIO53_IN0	12	GPIO56_OUT0
13	GPIO54_IN1	14	GPIO57_OUT1

2.5.2.18 COM2, COM3, COM4: Serial Ports

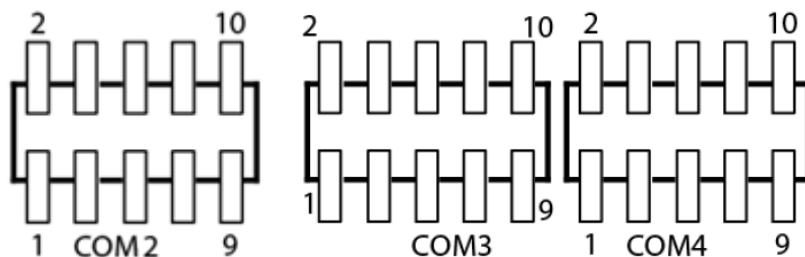

Pin №	Signal Name	Pin №	Signal Name
1	DCDE#	2	DSRE#
3	RXDE	4	RTSE#
5	TXDE	6	CTSE#
7	DTRE#	8	RIE#
9	GND	10	GND

2.5.2.19 NGFF_KEY_E1: NGFF M.2 KEY E Connector

IT32 NGFF M.2 connector supports M.2 card applications:

1. PCIe I/F + USB

2.5.2.20 NGFF_KEY_M1: NGFF M.2 KEY M Connector

IT32 NGFF M.2 connector supports M.2 card applications:

1. PCIe I/F + USB

Chapter 3: Driver Installation

This chapter contains driver installation instructions for IT32 motherboard

- 3.1 Chipset Driver Installation
 - 3.2 Graphic Driver Installation
 - 3.3 Management Engine (ME)
 - 3.4 Audio Driver Installation
 - 3.5 Ethernet Driver Installation
 - 3.6 DTT Installation
 - 3.7 GNA Installation
 - 3.8 Serial IO Driver
 - 3.9 Resistive Touch Driver for Windows 11 System
 - 3.10 Thermal Control AP
-

This chapter contains driver installation guide. Follow the instructions below to complete the installation. You will quickly complete the installation. This chapter provides instructions on how to install drivers on the IT32 Motherboard.

3.1 Chipset Driver

Follow instructions below to install Chipset driver.

1. Open the Driver CD (included in the package) and select **SetupChipset** driver.

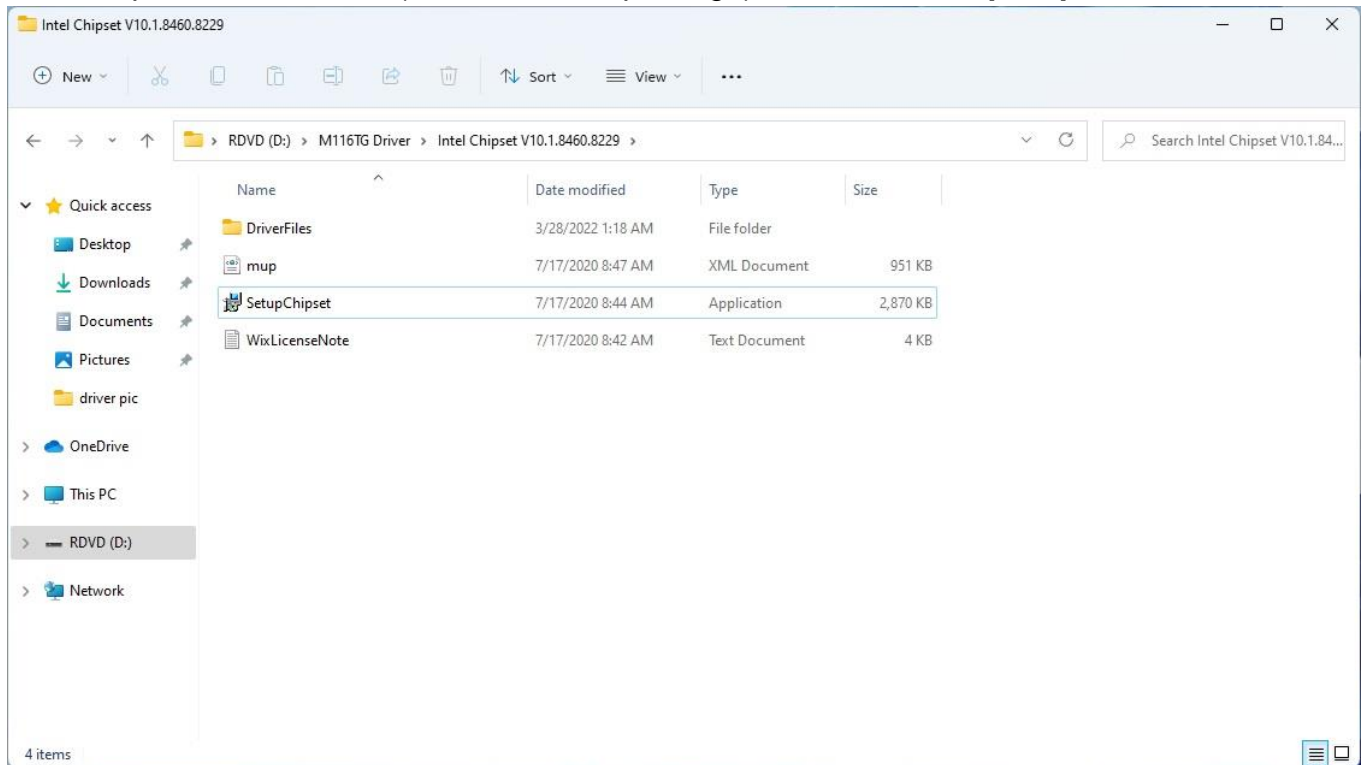

2. Installation window will pop up, select **Next**.



3. Select **Accept** to agree with the terms of license agreement.



4. Check the ReadMe file information, select **Install** to continue.



5. Wait for the driver to be installed. When installation completed, select **Restart Now** to restart your computer.



3.2 Graphic Driver

Follow instructions below to install Graphic driver.

1. Open the Driver CD (included in the package) and select **Installer** driver.

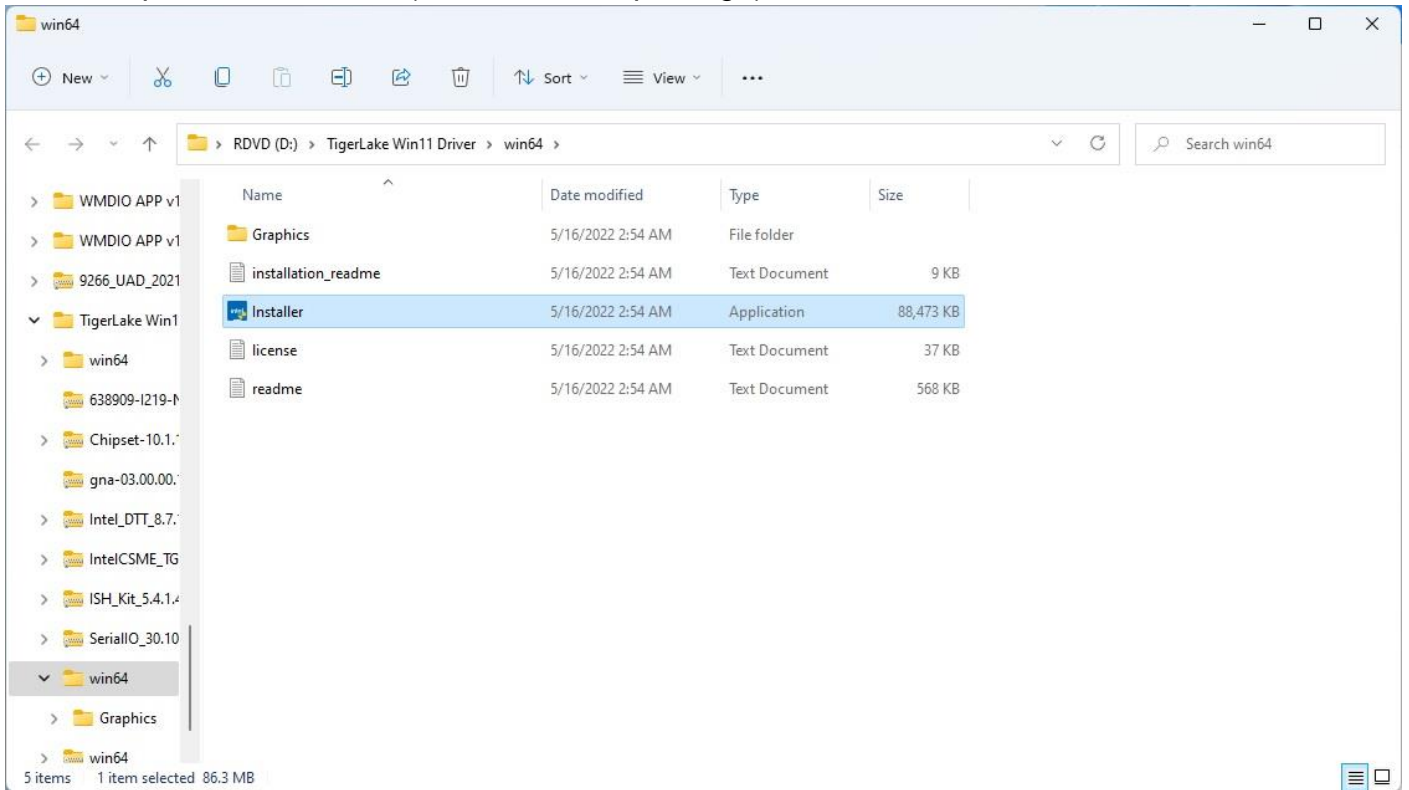

2. Installation window will pop up, click **Begin installation**



3. Check the **I agree to the Intel Terms and Conditions**, then click **Next >**.

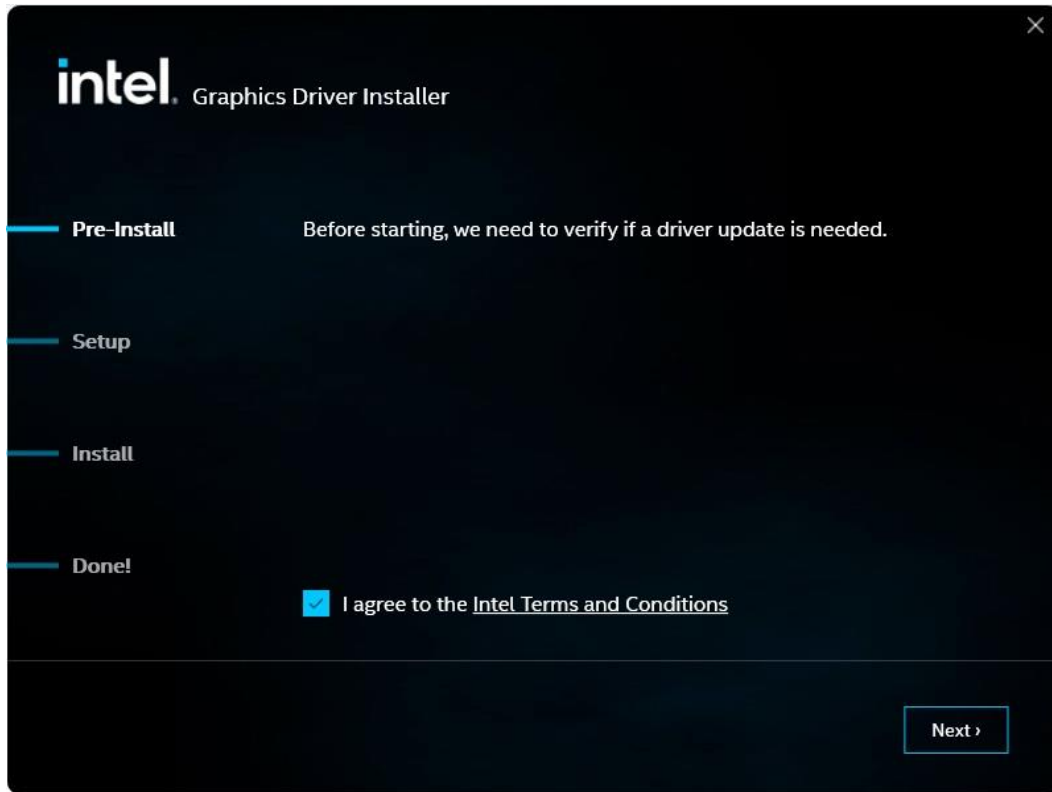

4. After installation is completed, click **Finish**.

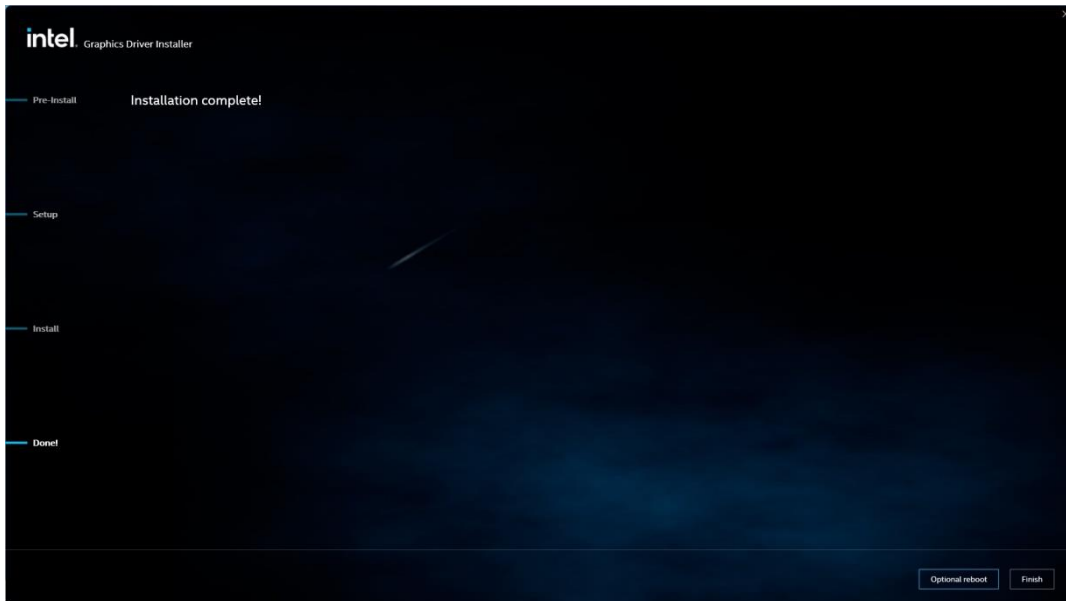

3.3 Management Engine (ME)

Follow instructions below to install Management Engine (ME) .

1. Open the Driver CD (included in the package) and select **MEISetup** driver.

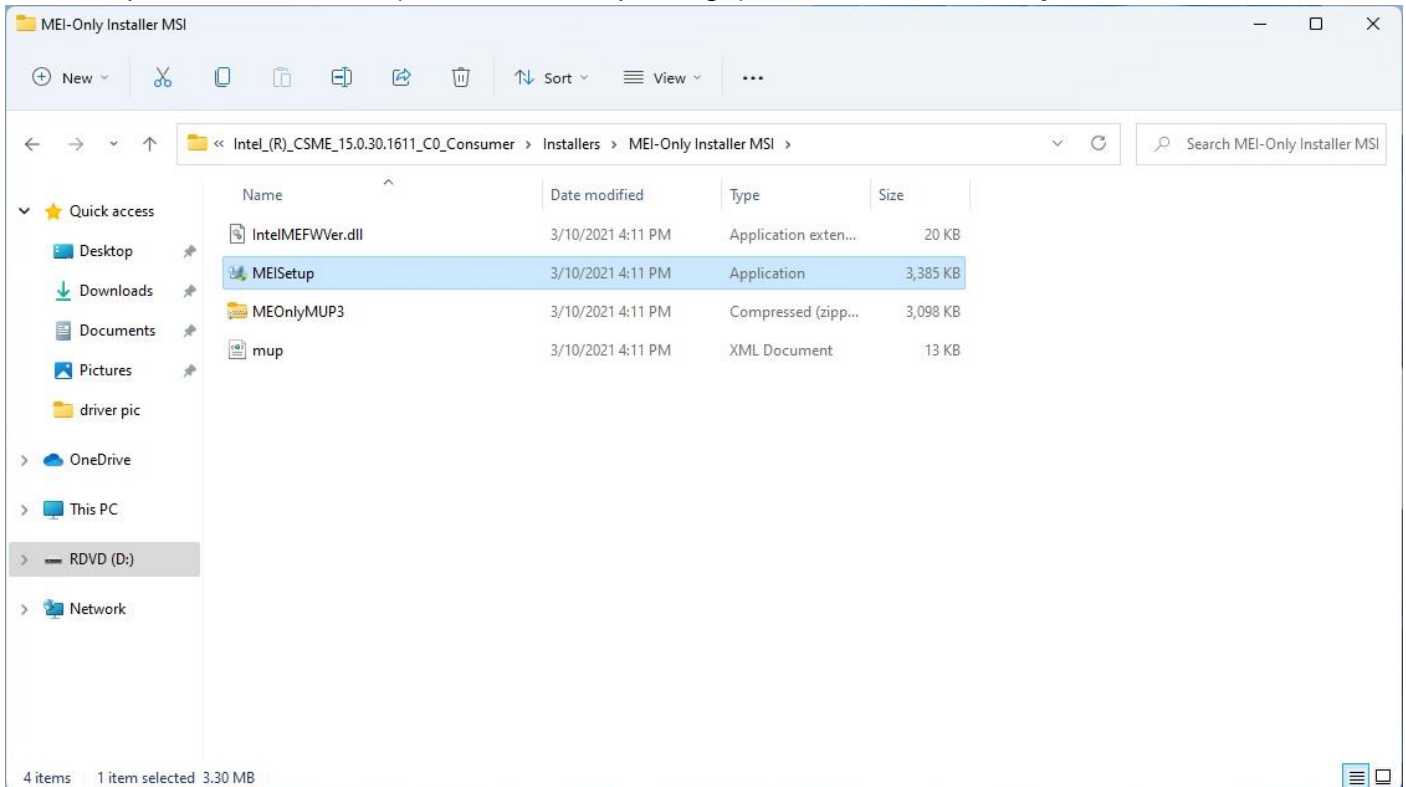

2. Select **Next** to start the installation.

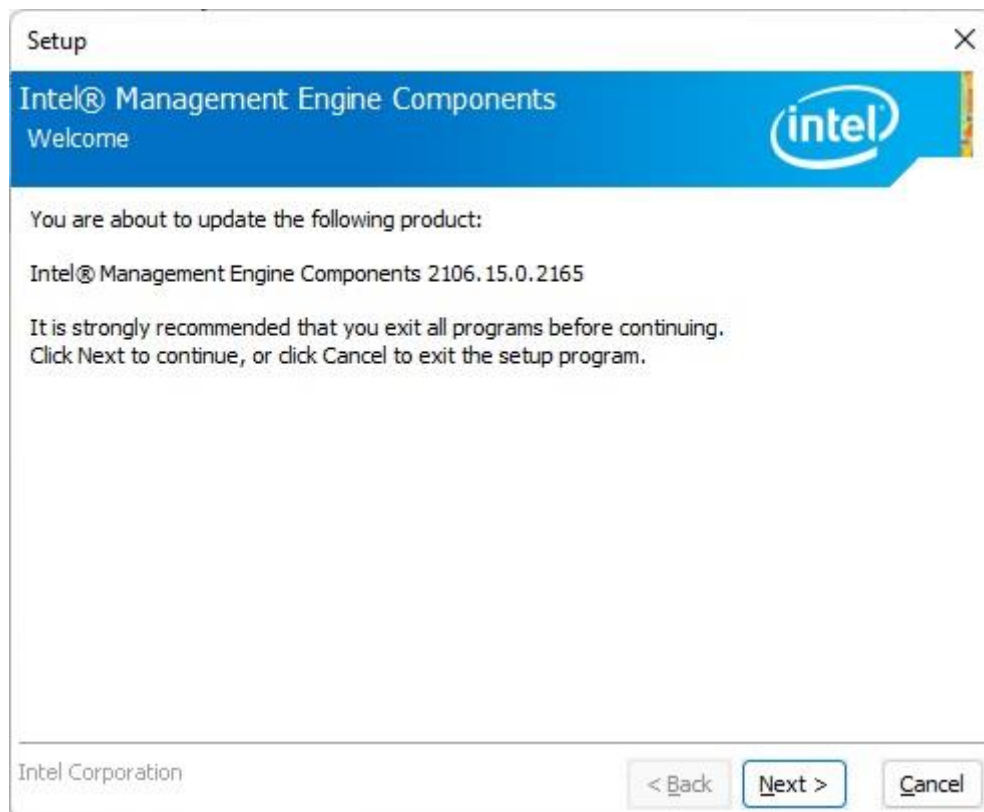

Select **Next** to agree with the terms of license agreement.

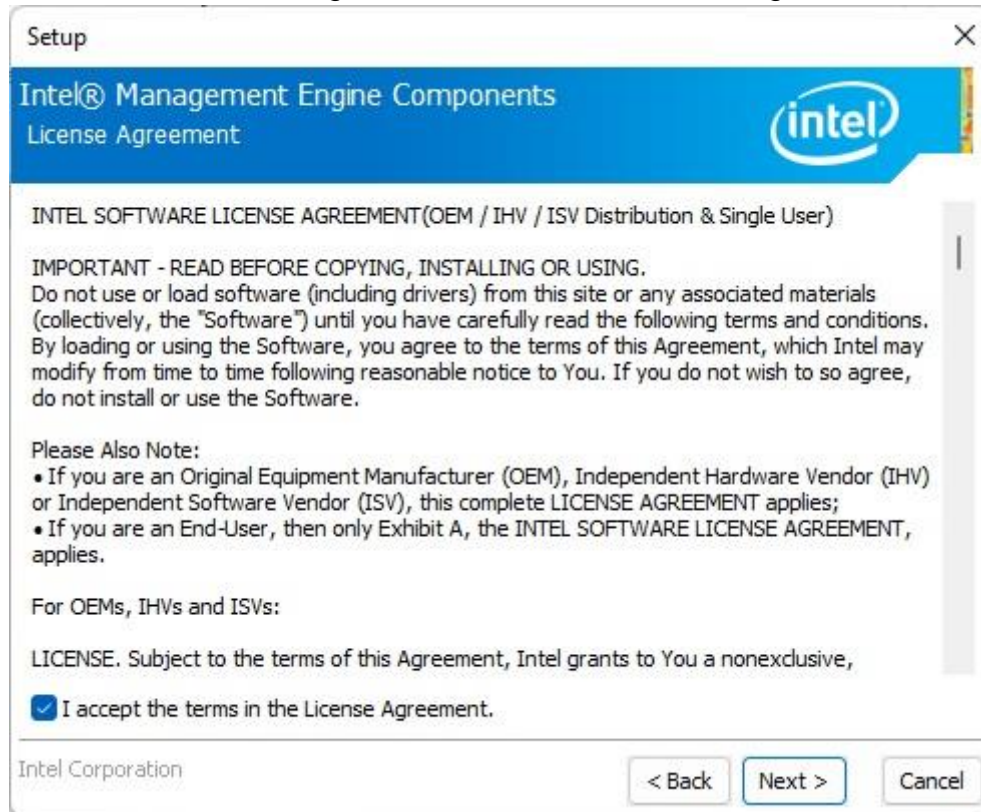

3. When installation completed, select **Finish** complete installation.

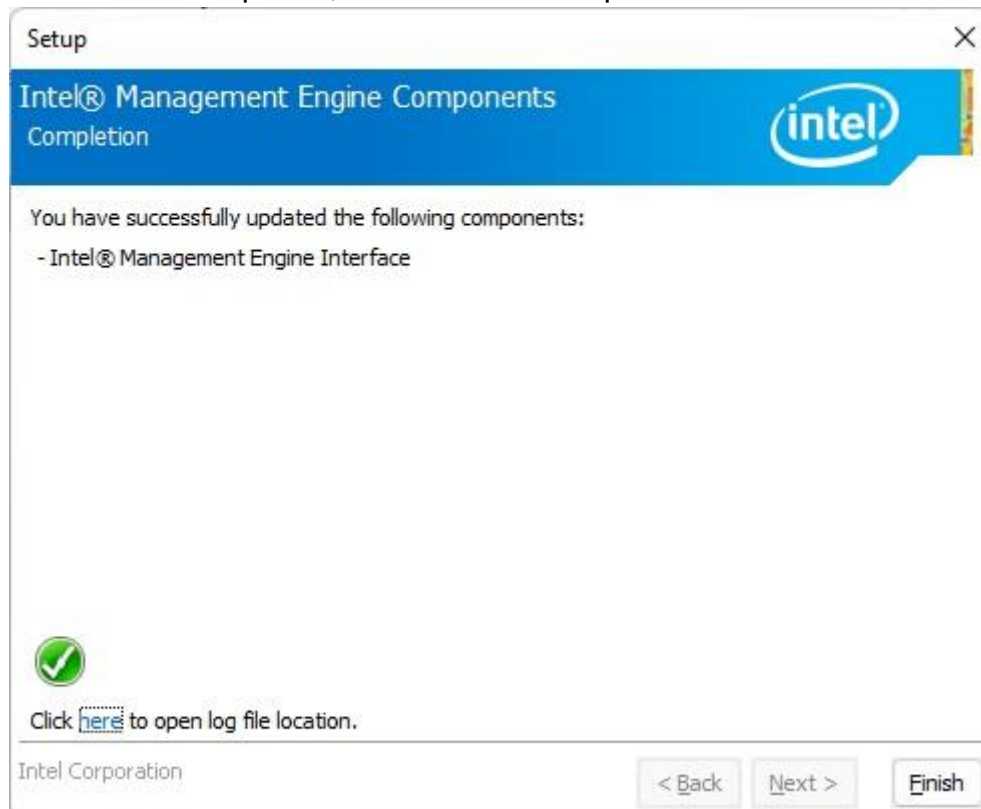

3.4 Audio Driver

Follow instructions below to install Audio driver.

1. Open the Driver CD (included in the package) and select **Setup** driver.

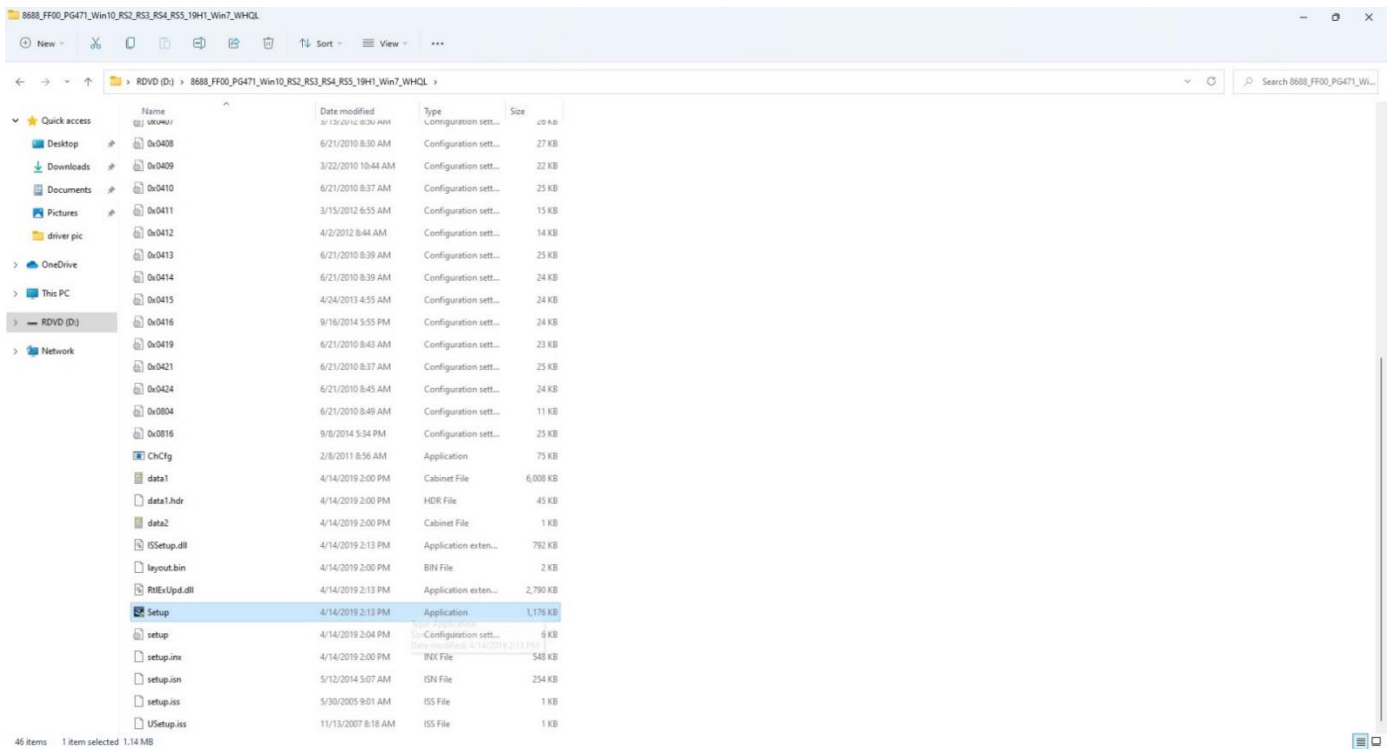

2. Select **Next** to continue.

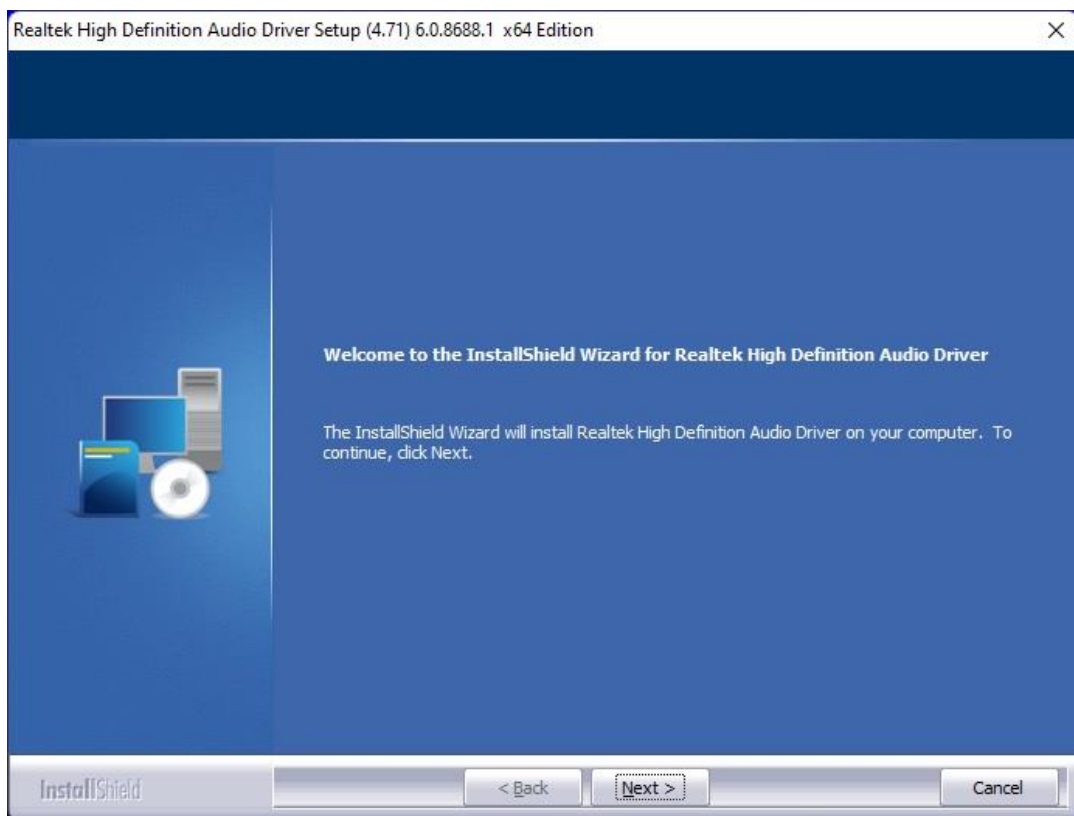

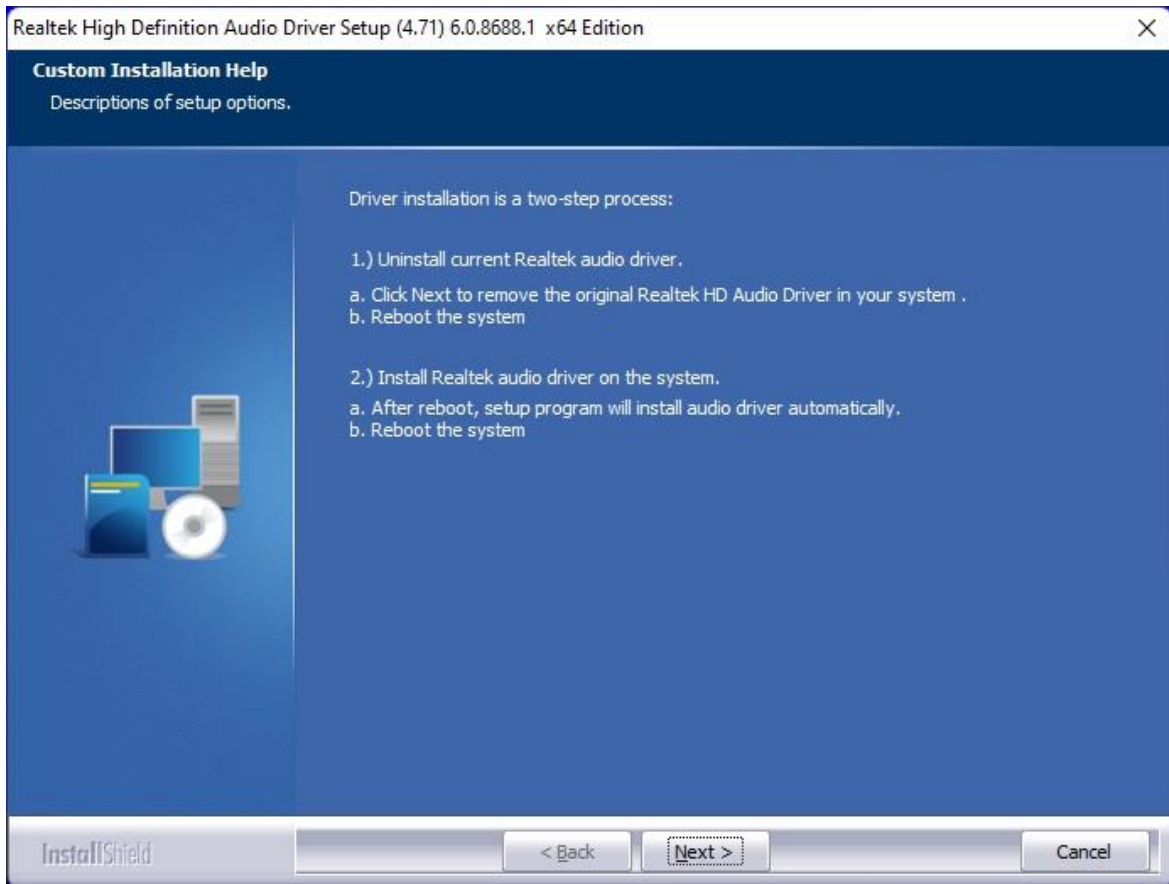

3. When installation completed, select **Yes, I want to restart my computer now**. Then click **Finish**.

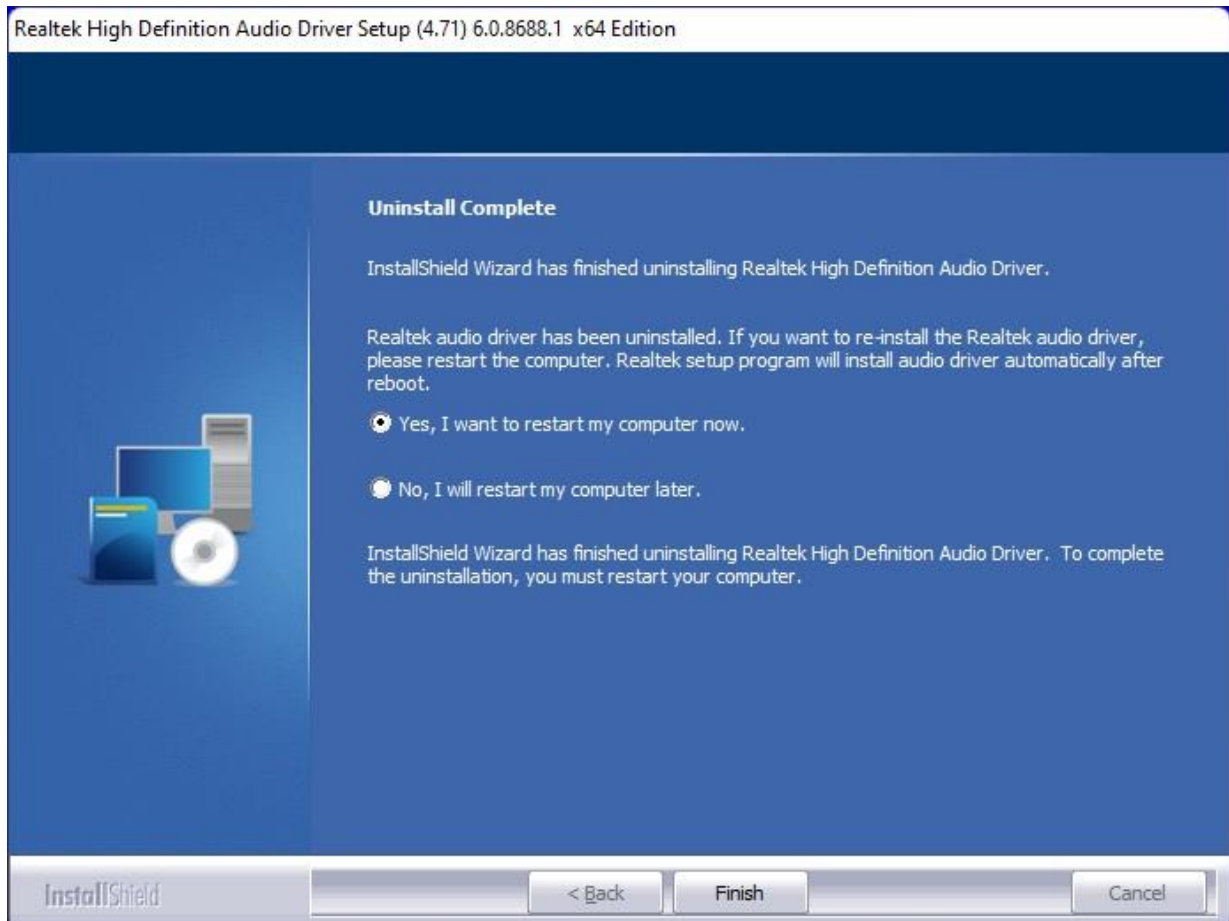

3.5 Ethernet Driver

Follow instructions below to install LAN driver.

1. Open the Driver CD (included in the package) and select **LAN** driver.

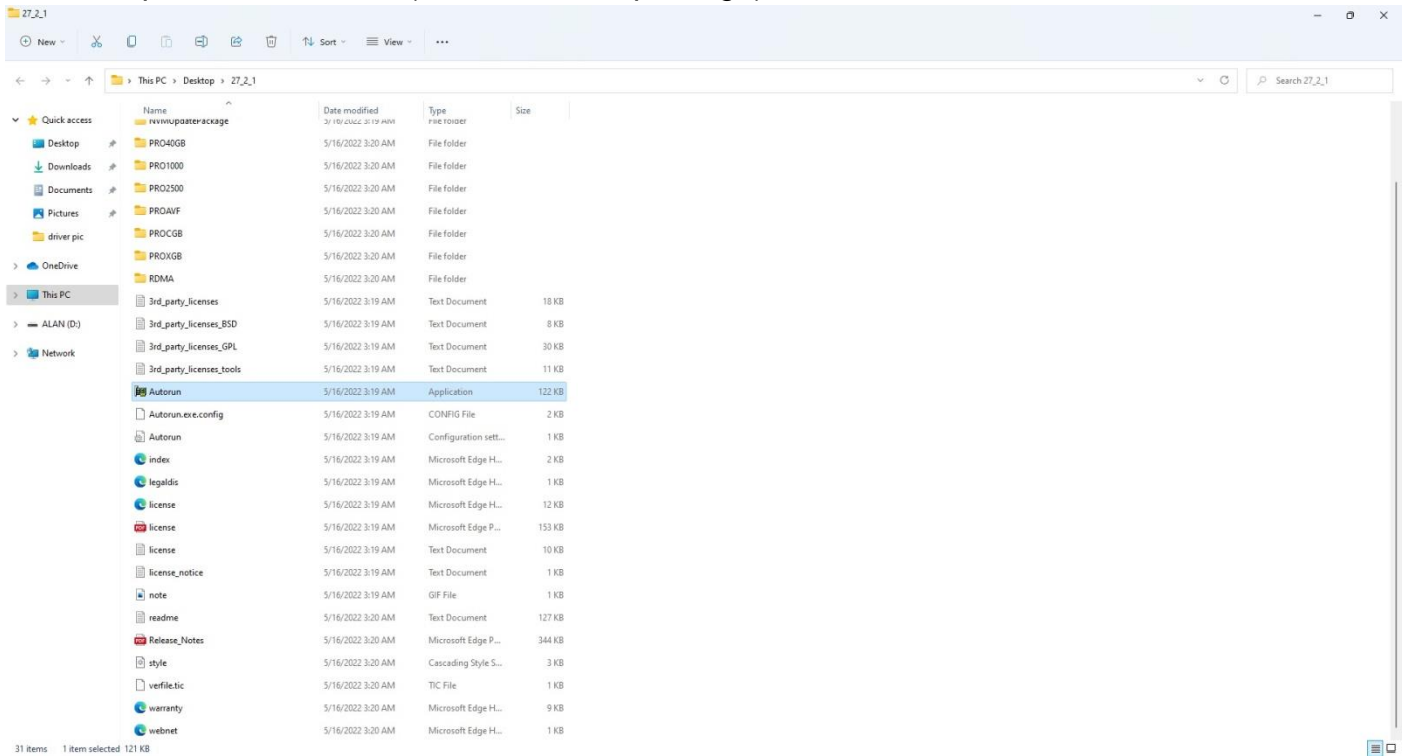

2. When compression is complete, select **Install Drivers**.

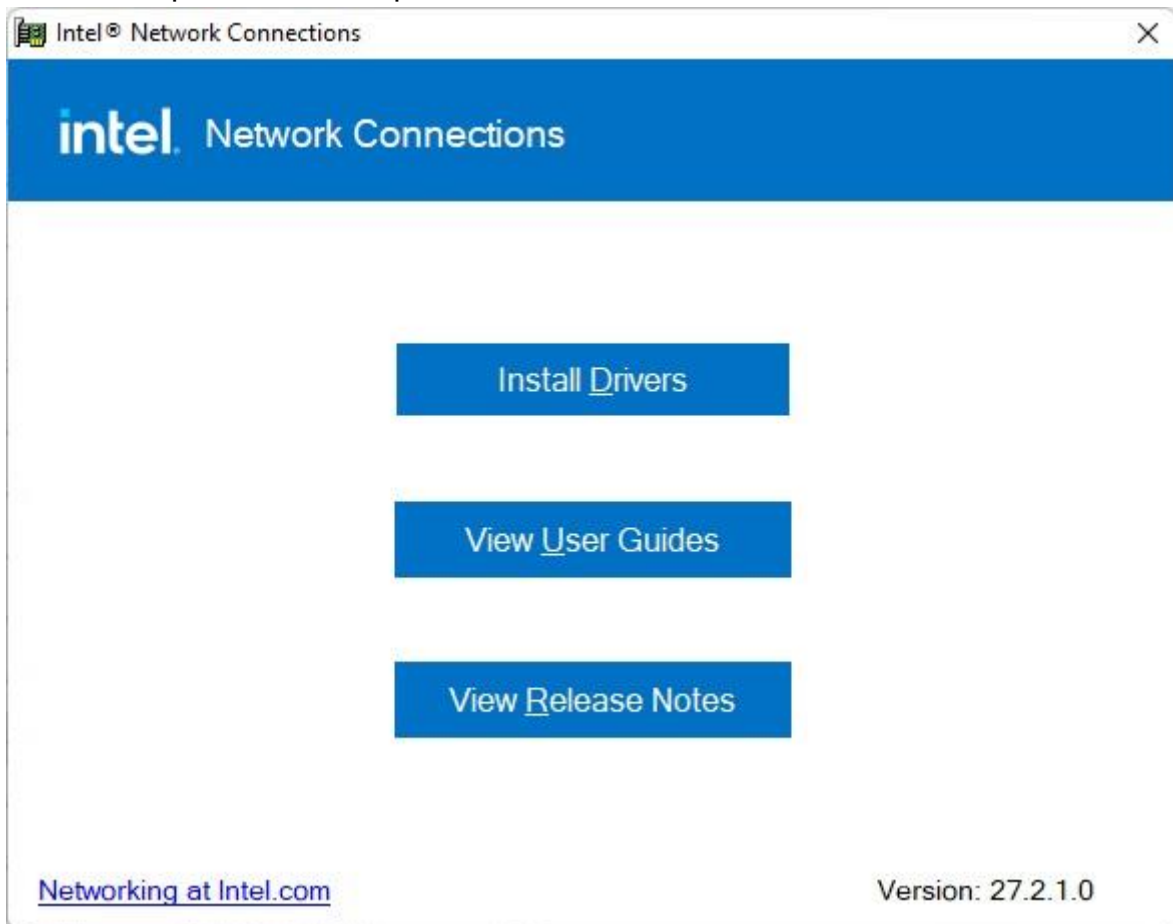

3. Select **OK**.

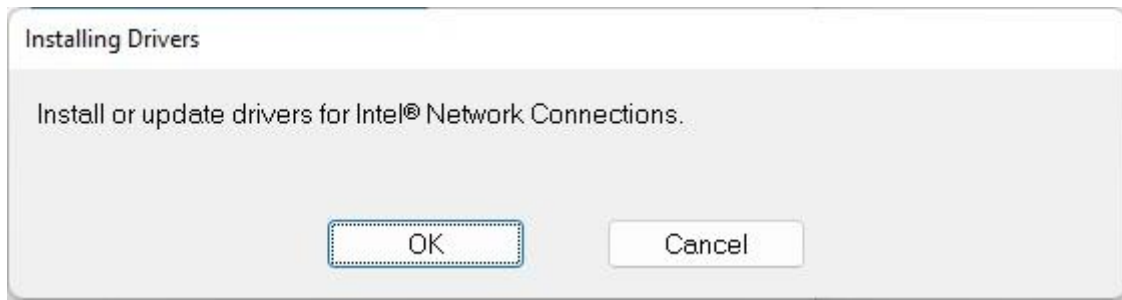

4. Select **Close** to close the window.

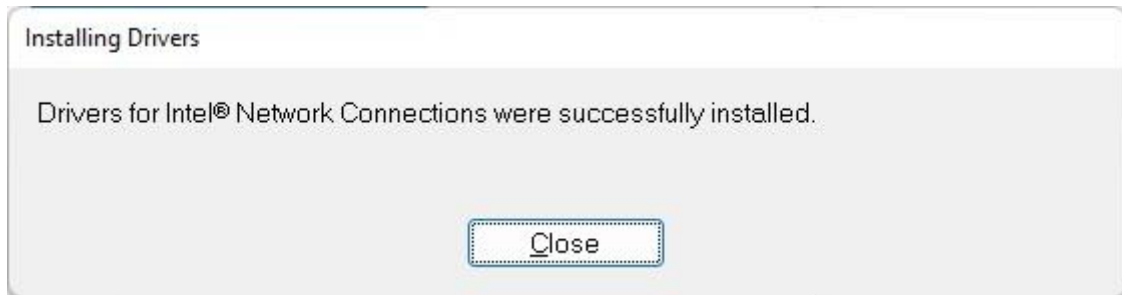

3.6 DTT Driver

Follow instructions below to install DTT driver.

1. Open the Driver CD (included in the package) and select **DTT** driver.

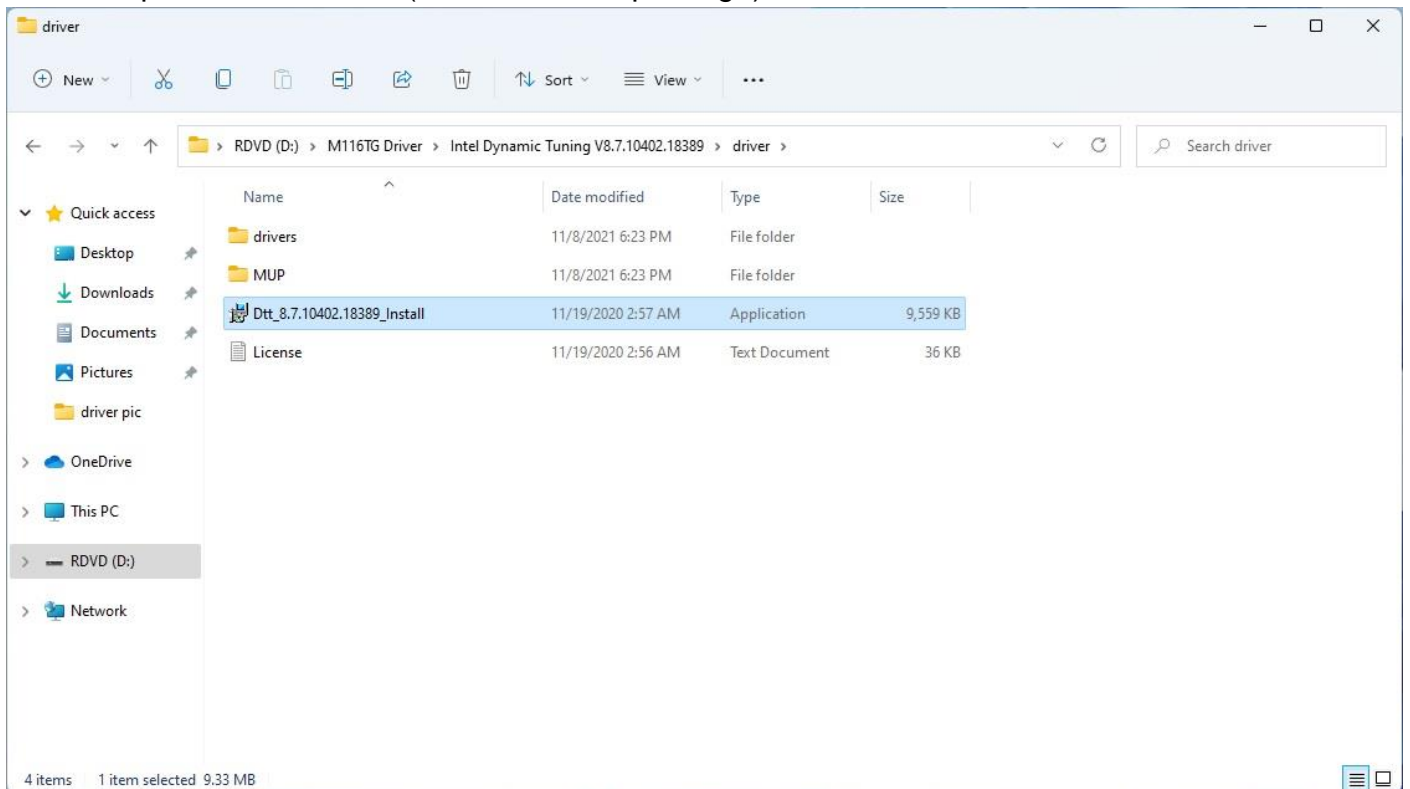

2. When compression is complete, select Next.



3. Read the license agreement, and then select Yes.

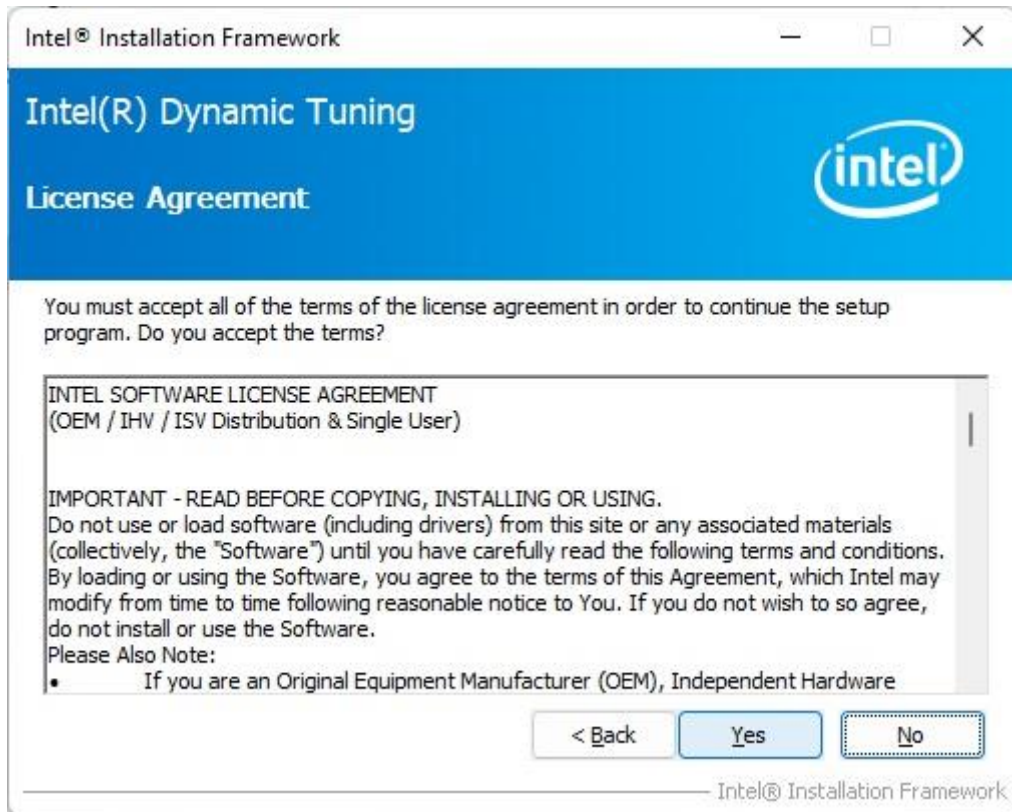

4. System displays the installed packages, select Next.

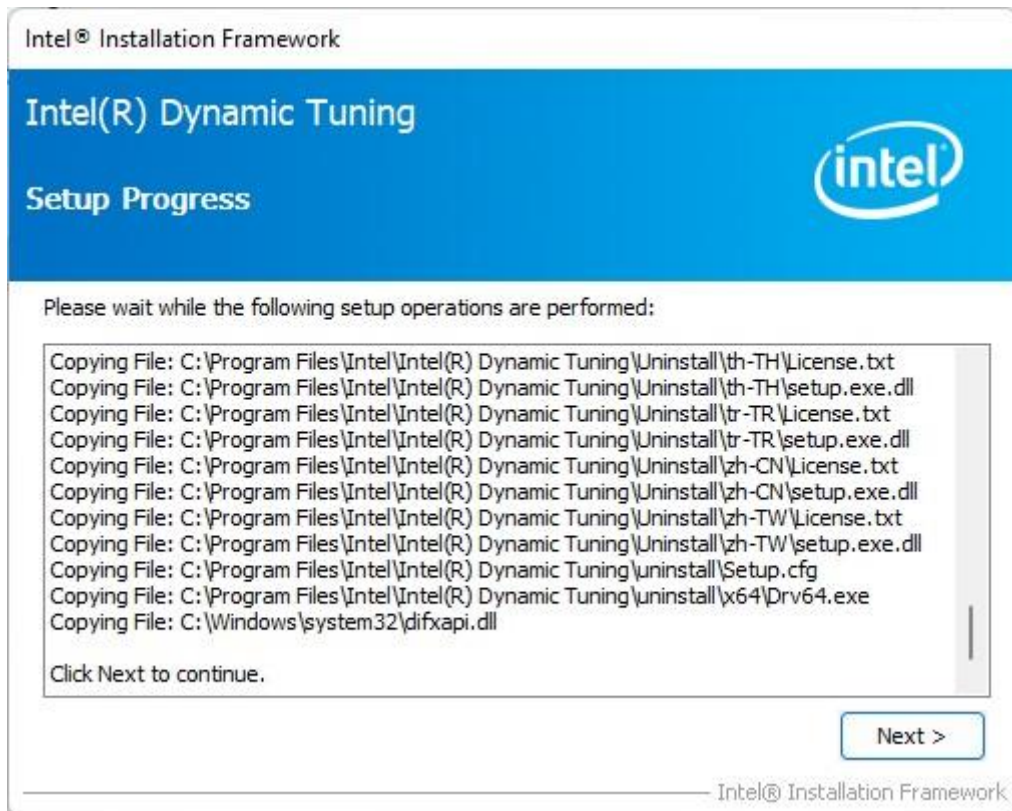

5. When installation is completed, select Finish to close the window.

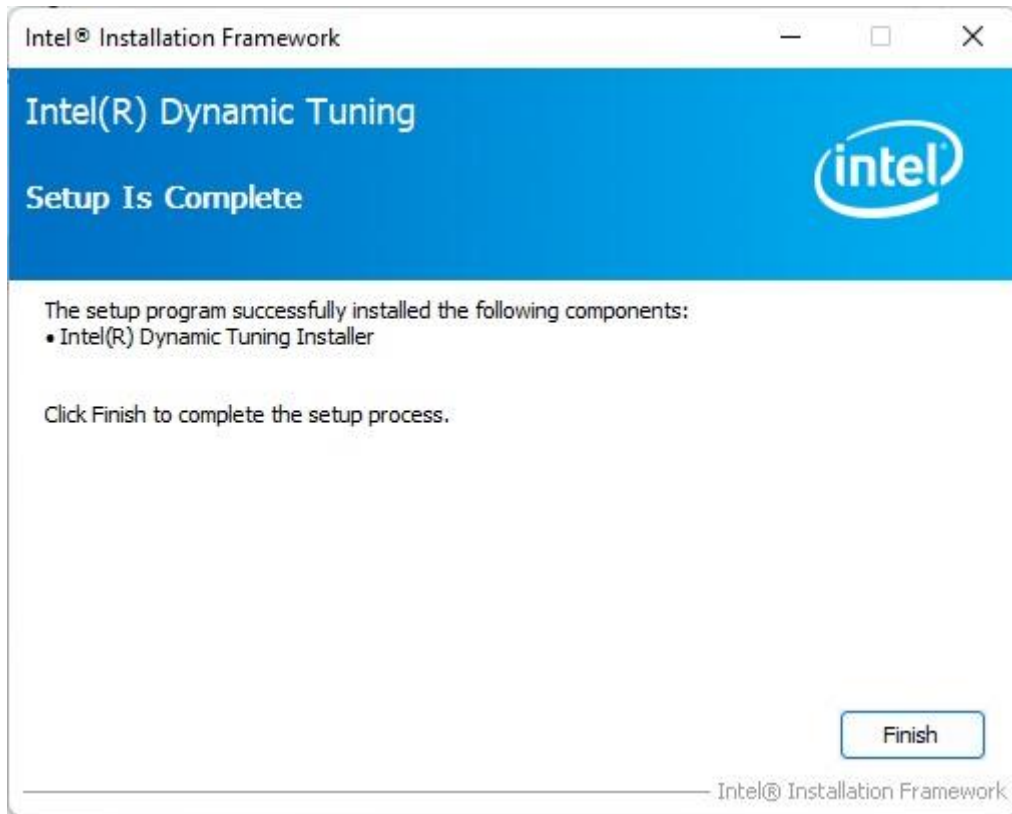

3.7 GNA Driver

Follow instructions below to install GNA driver.

1. Open the Driver CD (included in the package) and select **GNA** driver.

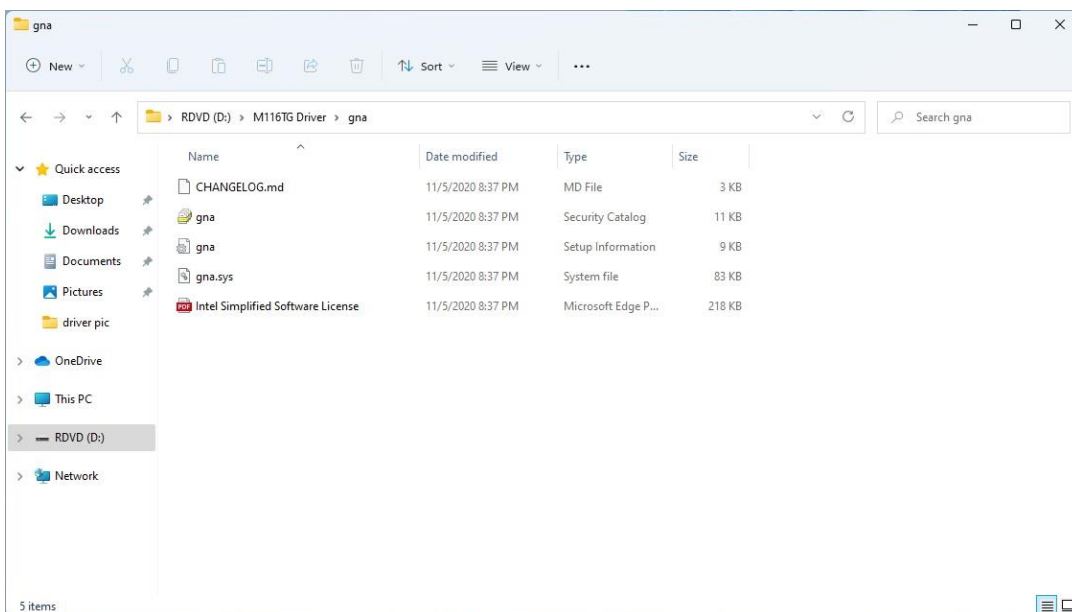

2. Right click, select **Install**.

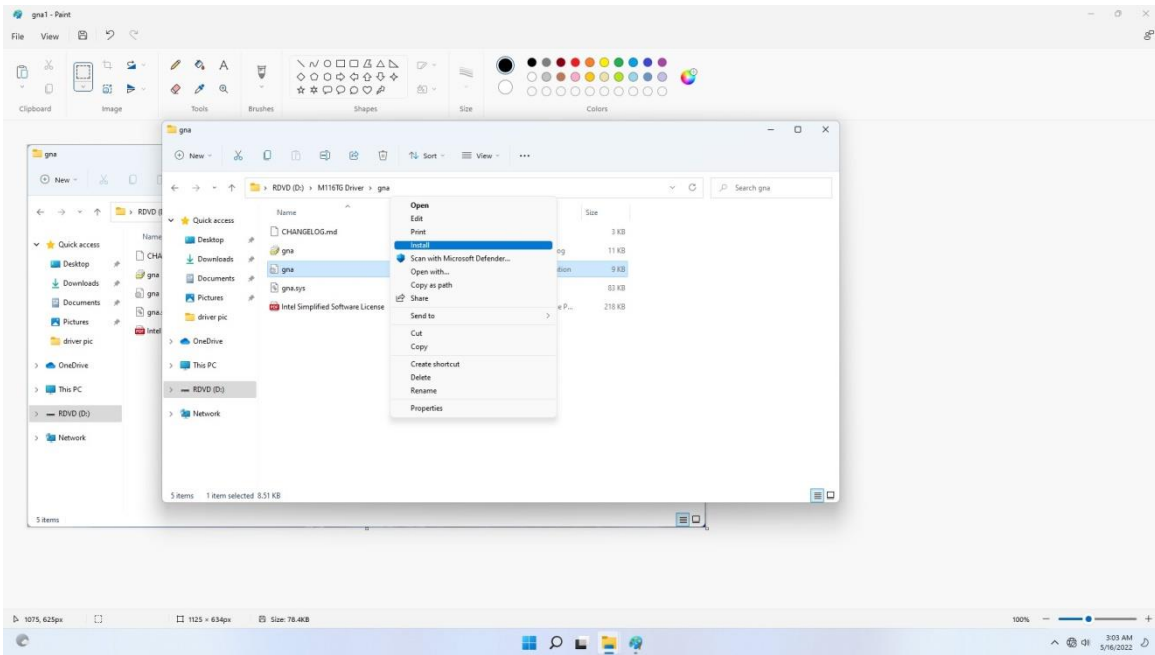

3.8 Serial IO Driver

Follow instructions below to install SIO driver.

1. Open the Driver CD (included in the package) and select **SetupSerialIO** driver.

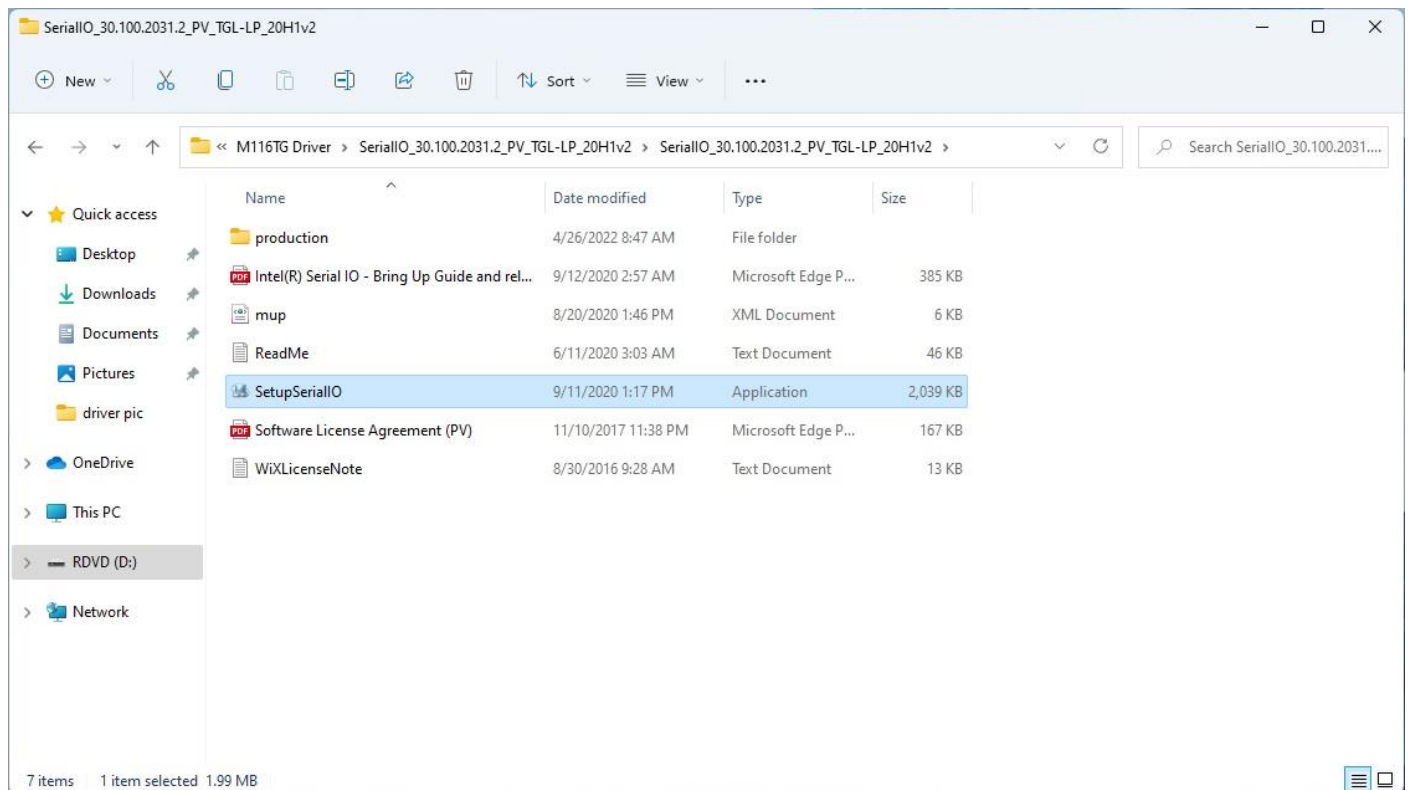

2. Select **Next** to start the installation.



3. Select **Next** to agree with the terms of license agreement.

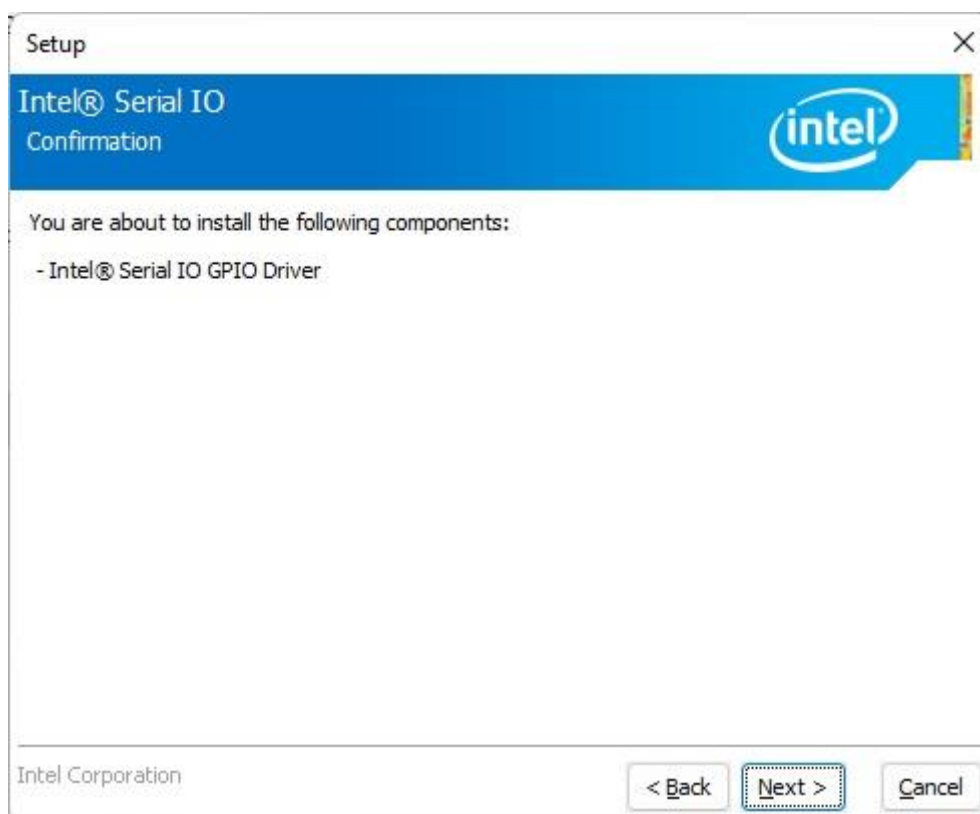
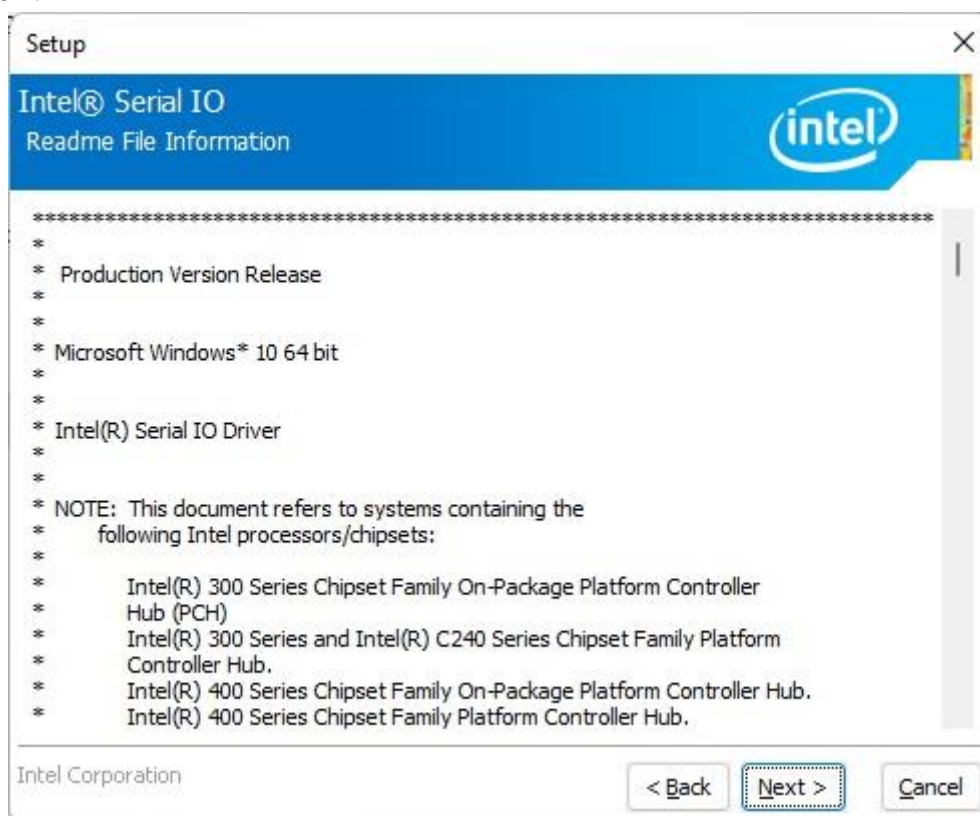

4. Click **Next**.

- When installation completed, select **Yes, I want to restart my computer now**. Then click **Finish**.



3.9 Resistive Touch Driver for Windows 11 System

Follow instructions below to install touch driver.

- Click **setup**

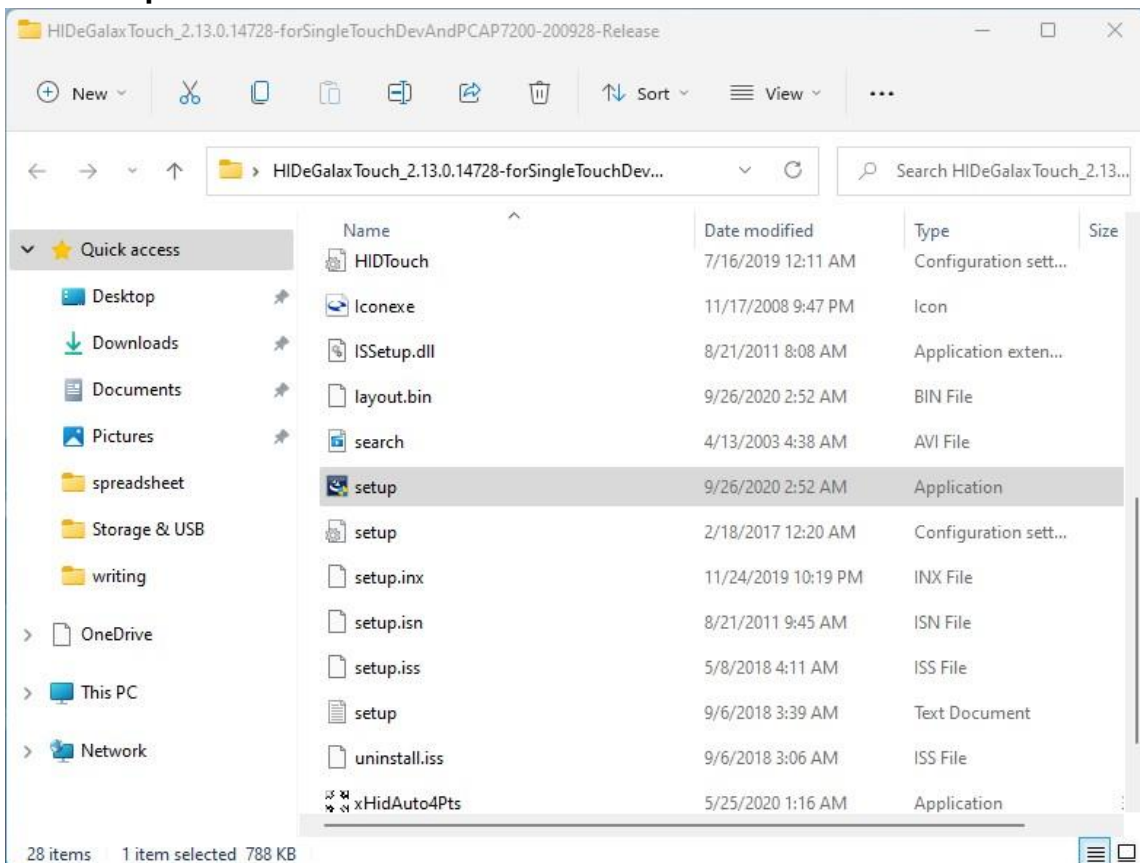

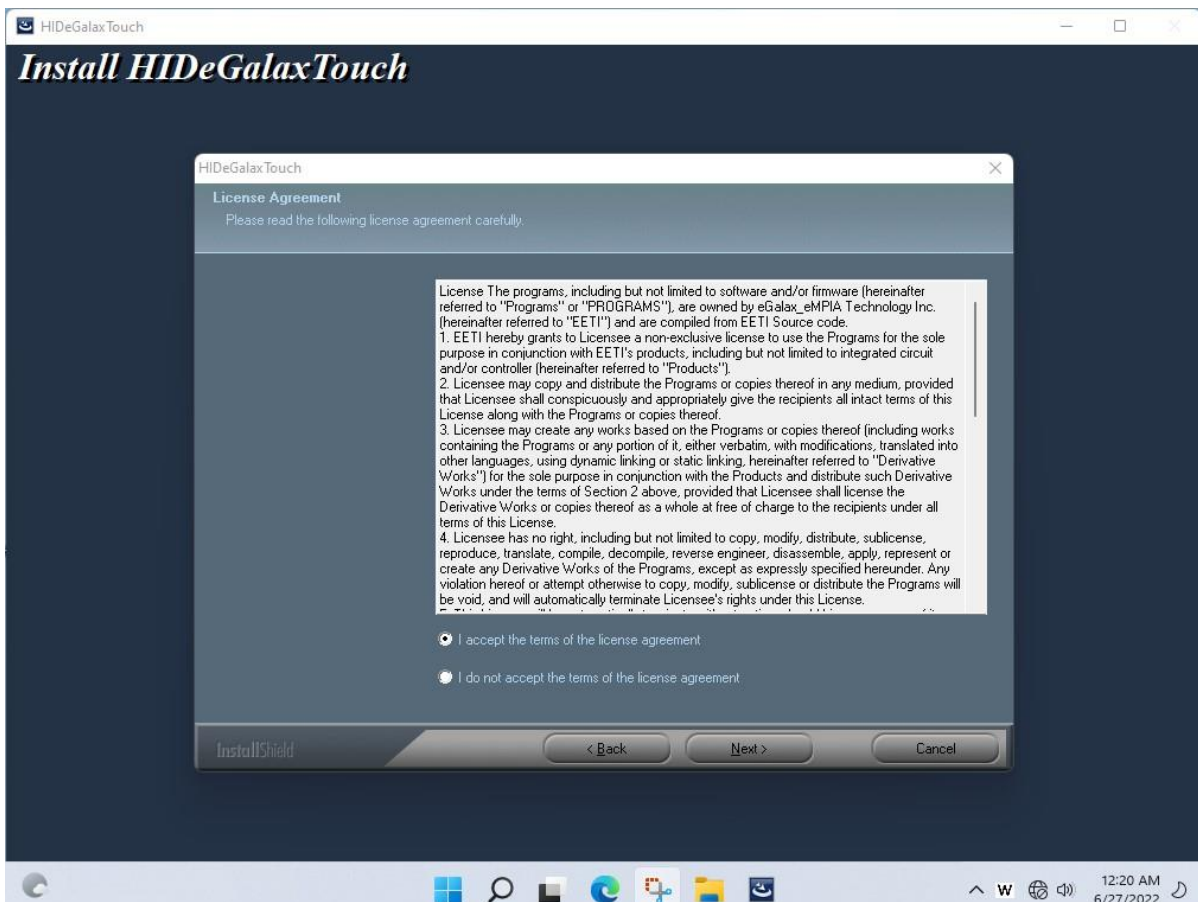
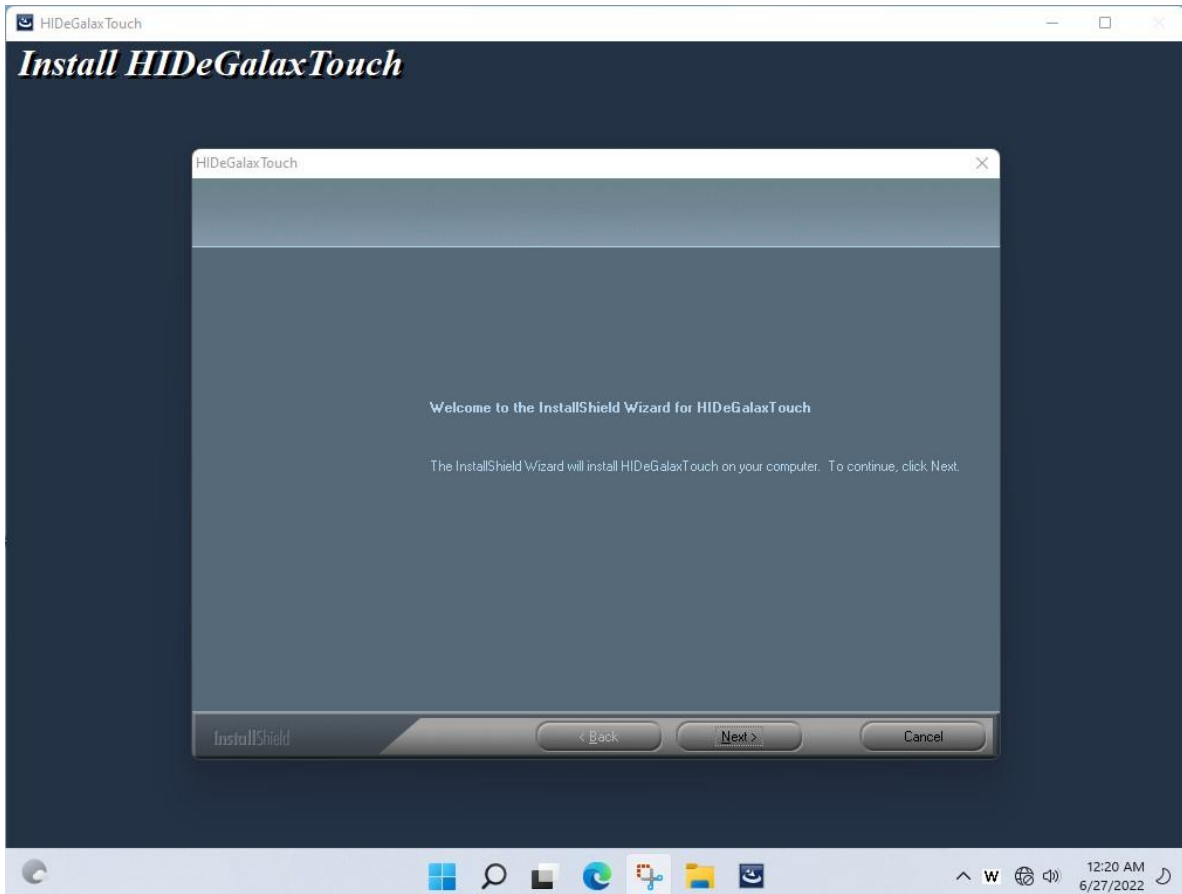
2. Click **Next** to continue

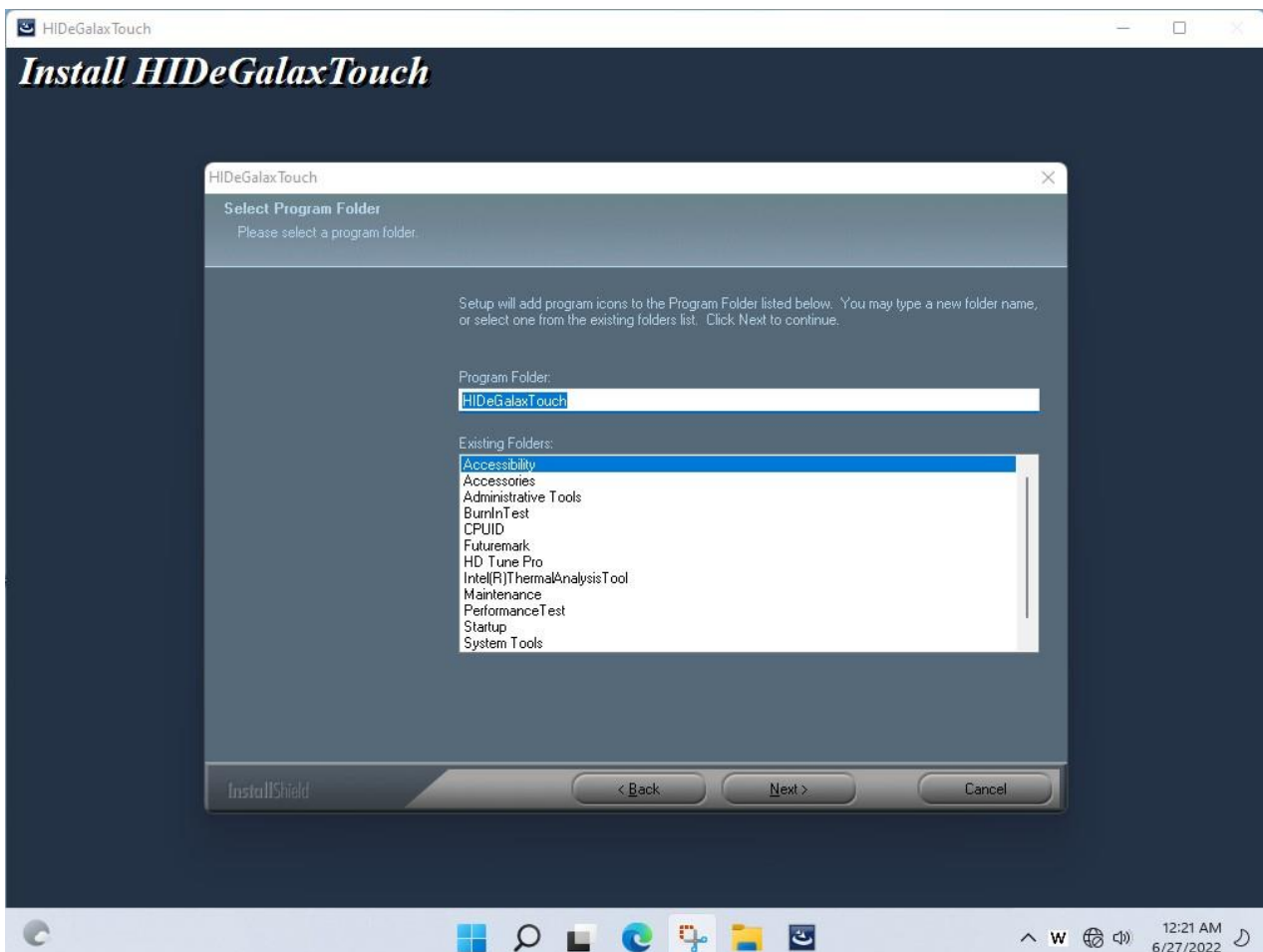
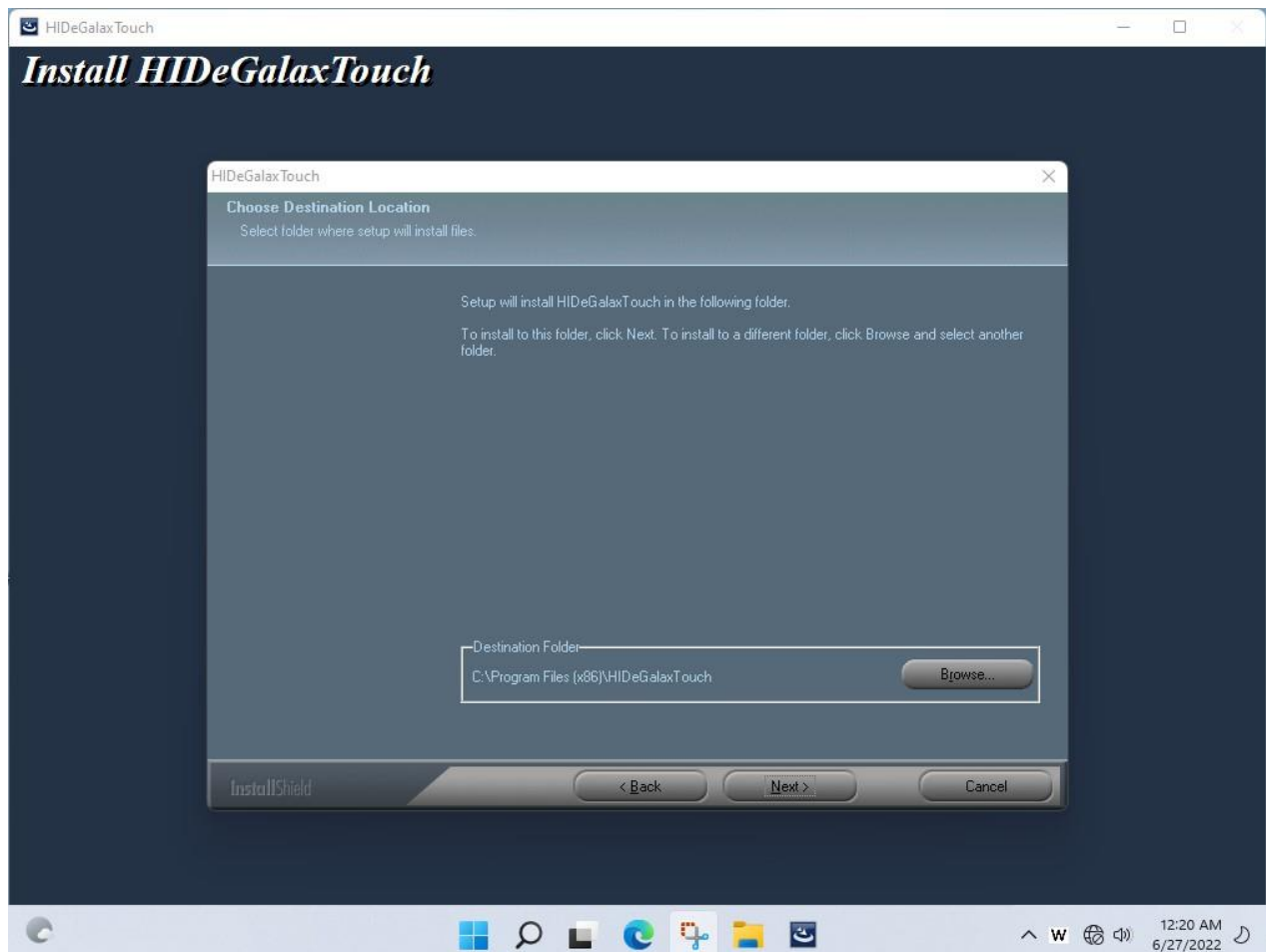

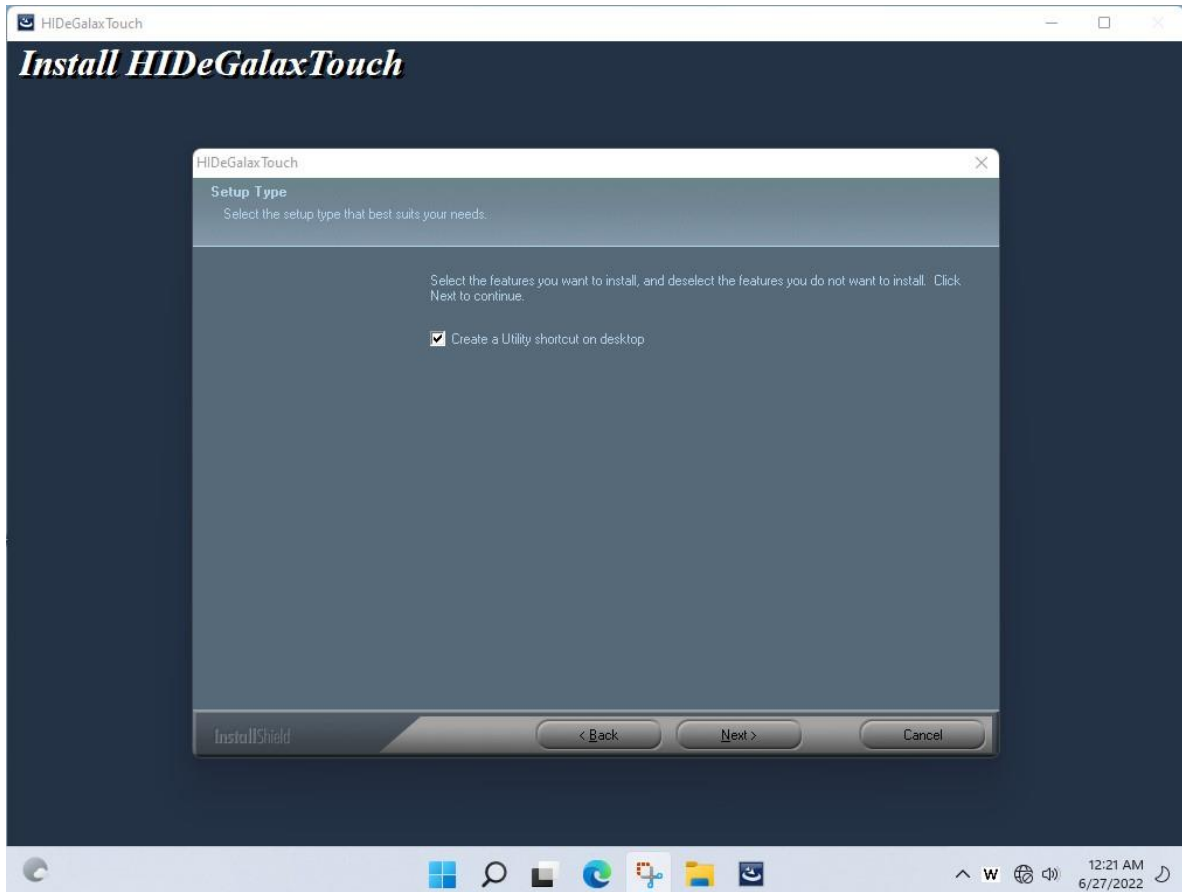

3. Click **Yes** to add this controller.

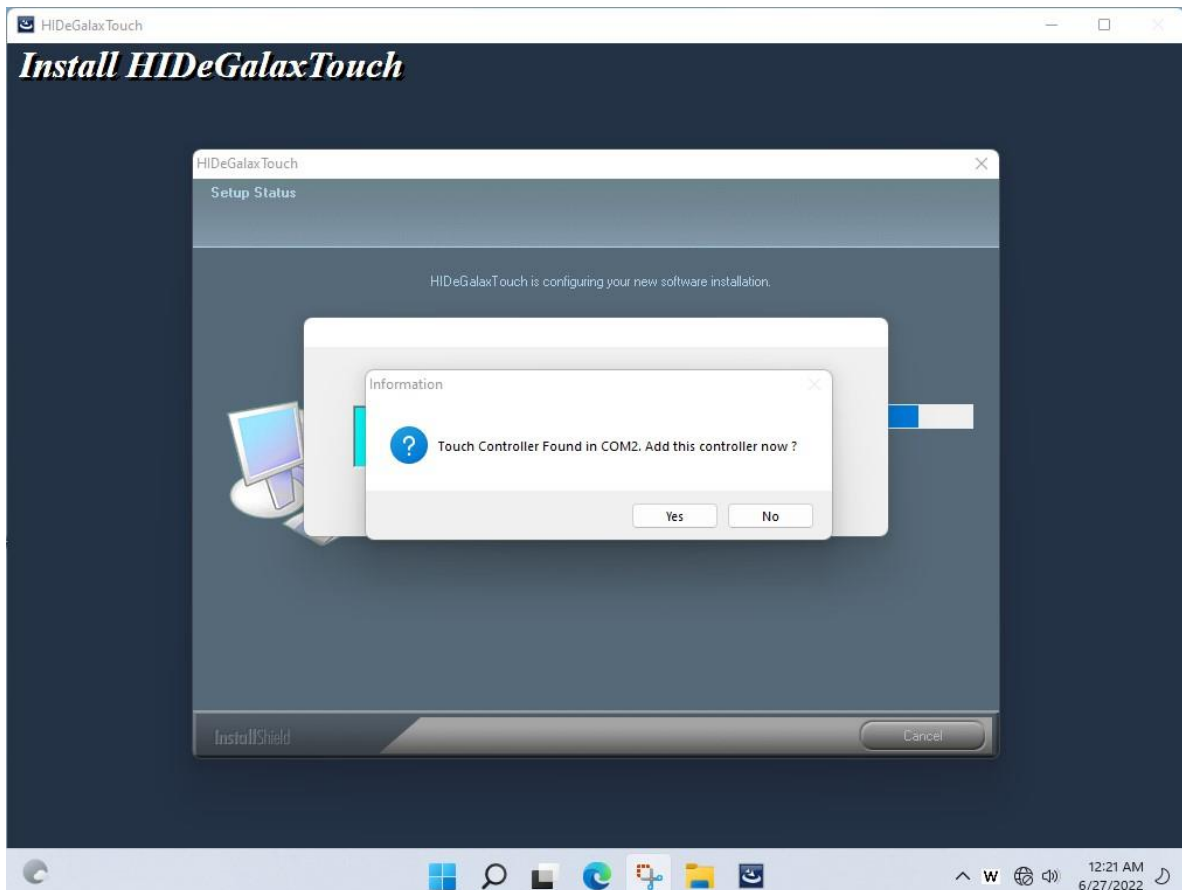

4. Restart the computer now and finish the setup.

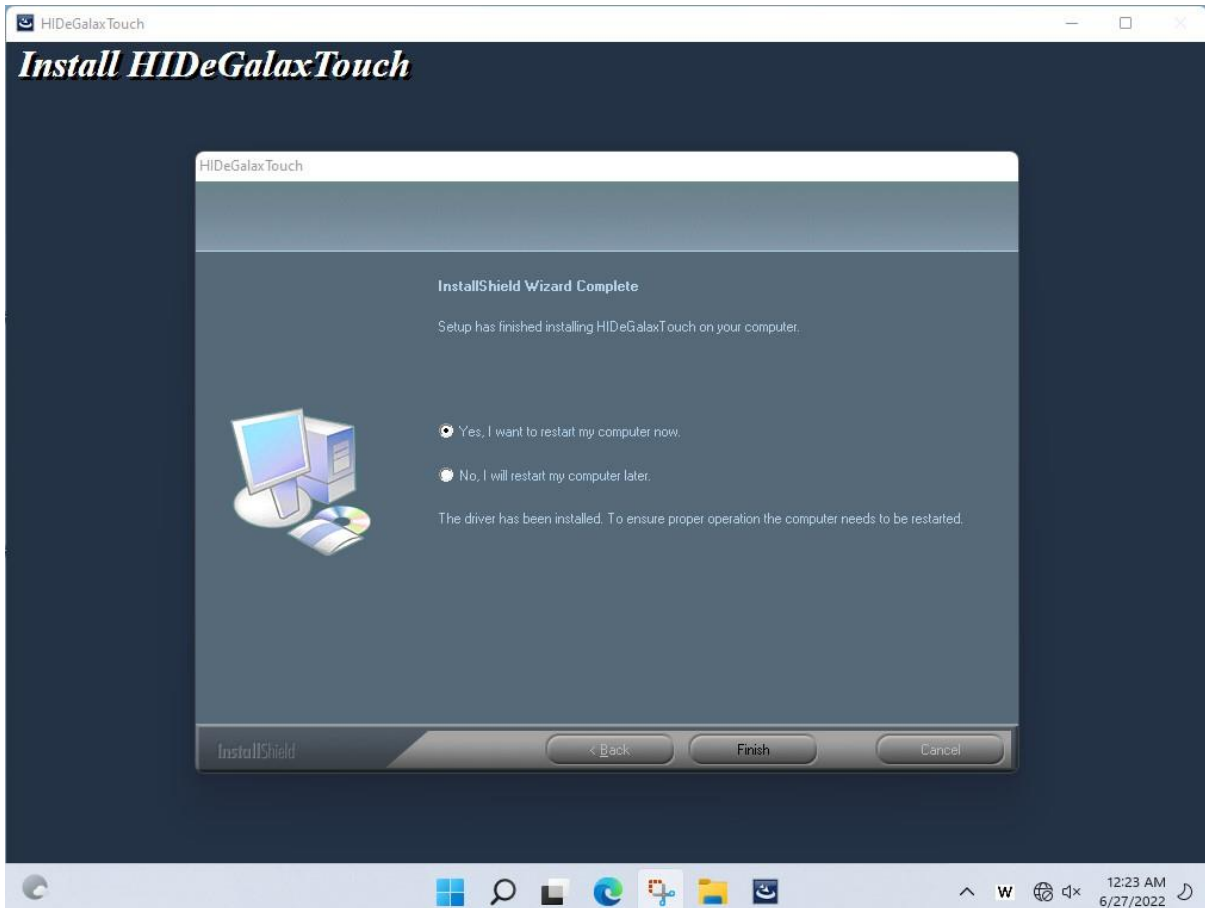

3.10 Thermal Control AP

Follow instructions below to install Thermal Control AP.

1. Click **Driver**.

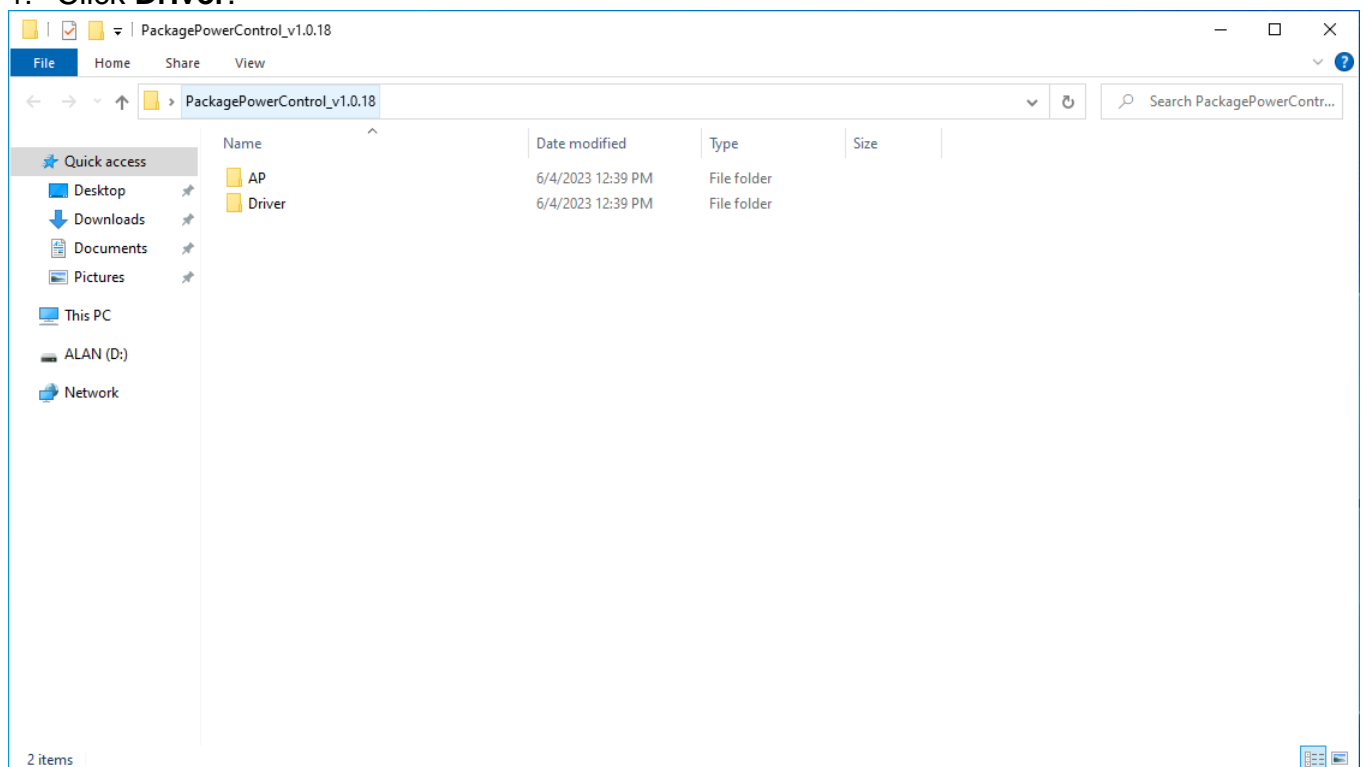

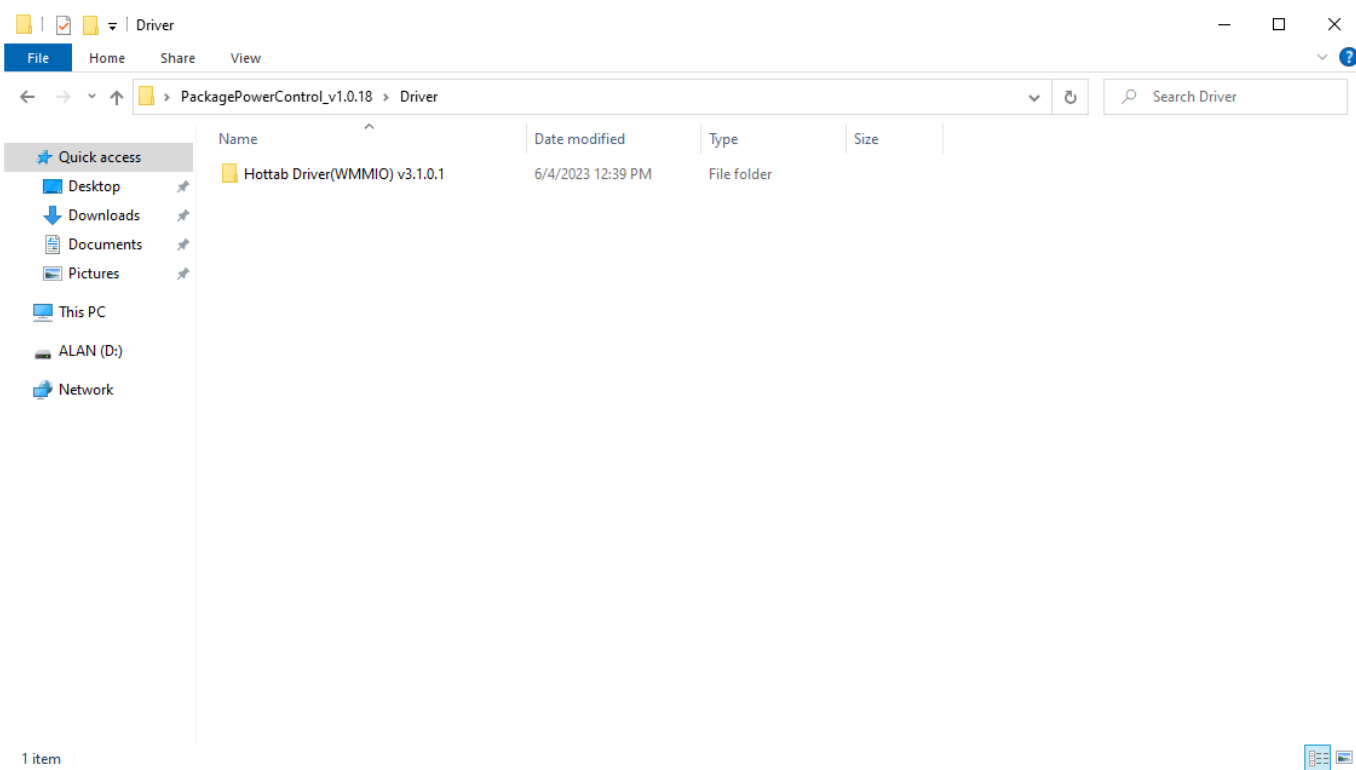

2. Click **WMMIO_64bit**.

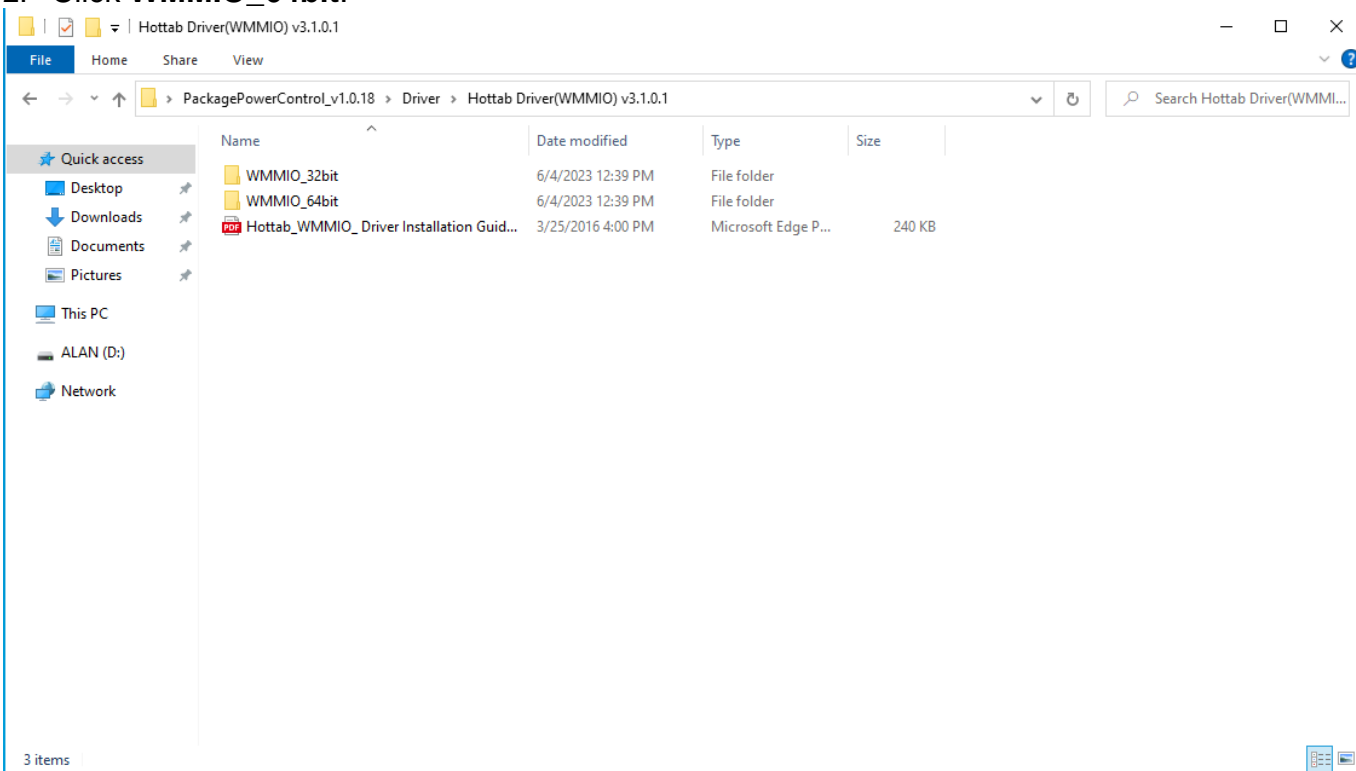

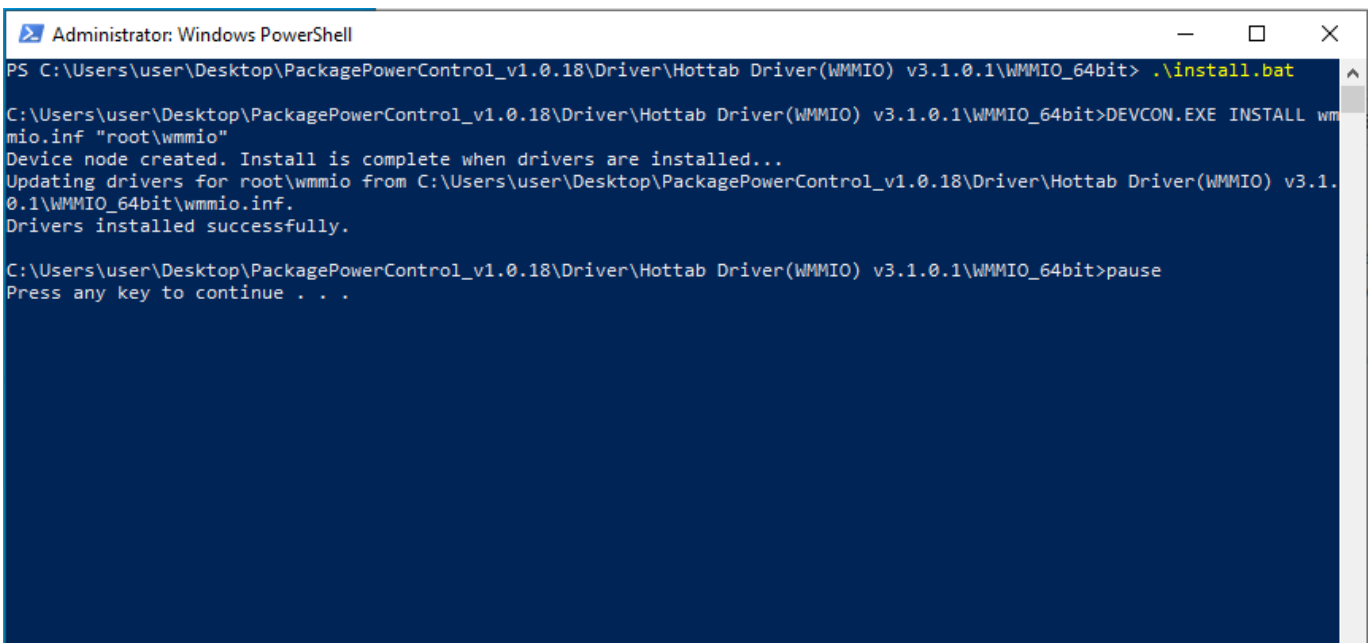
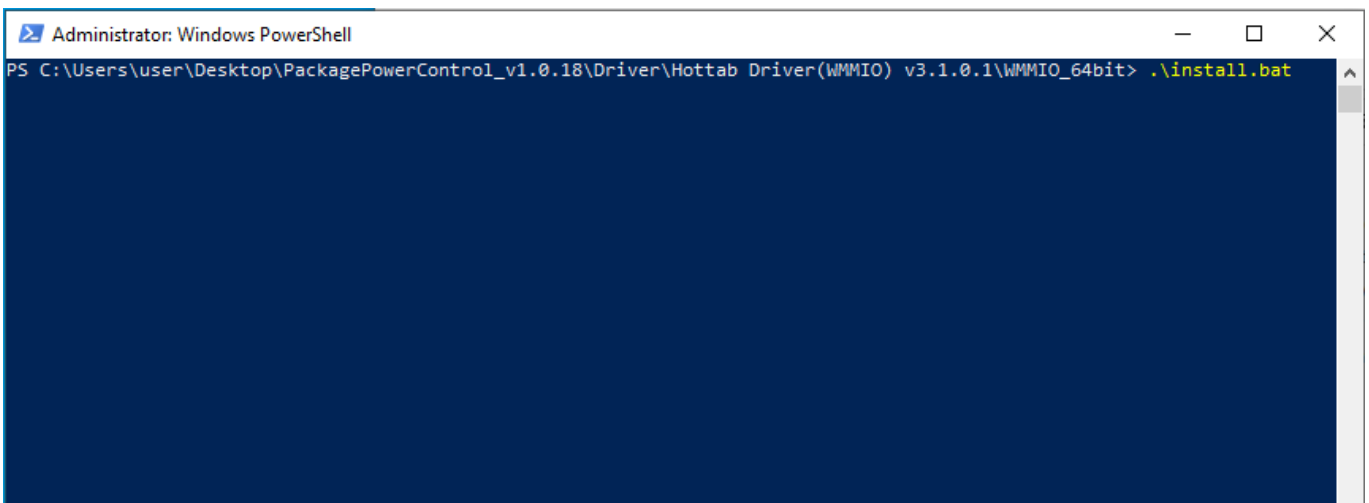
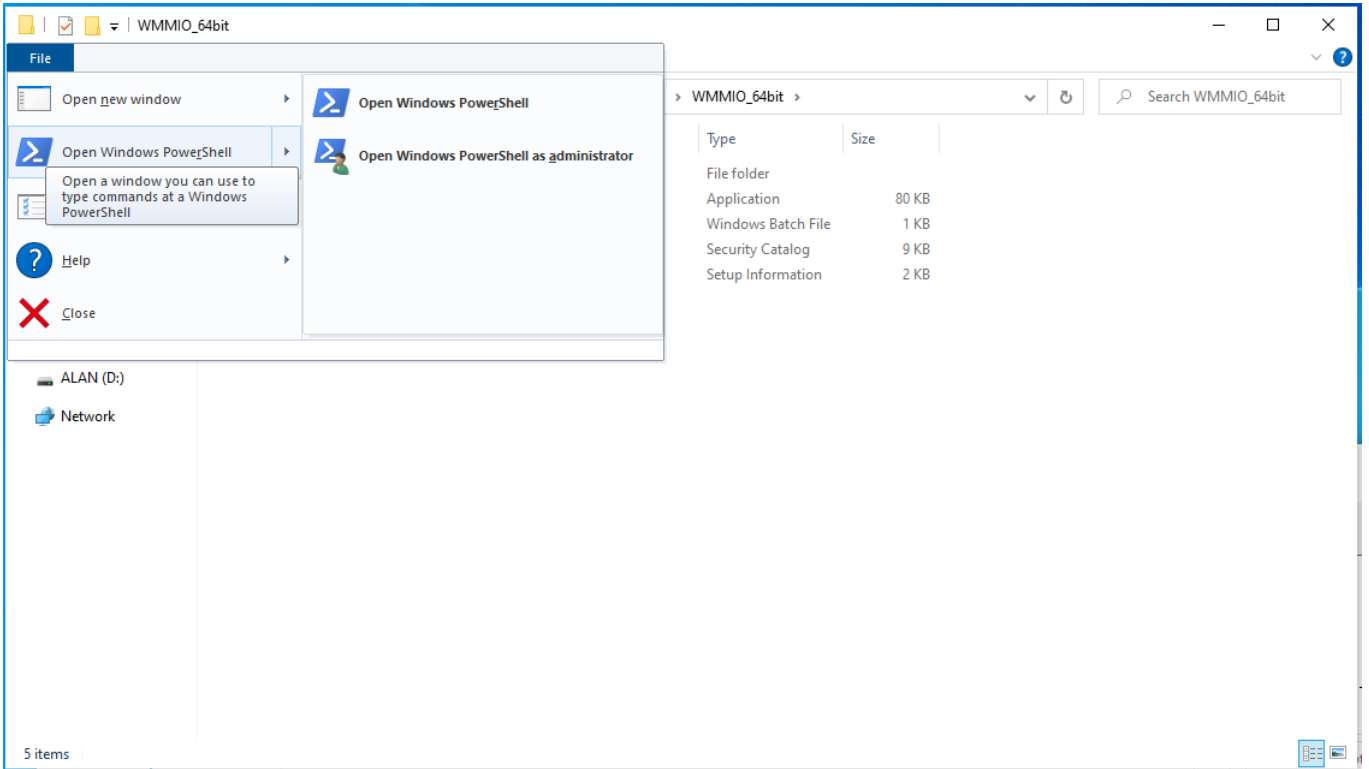

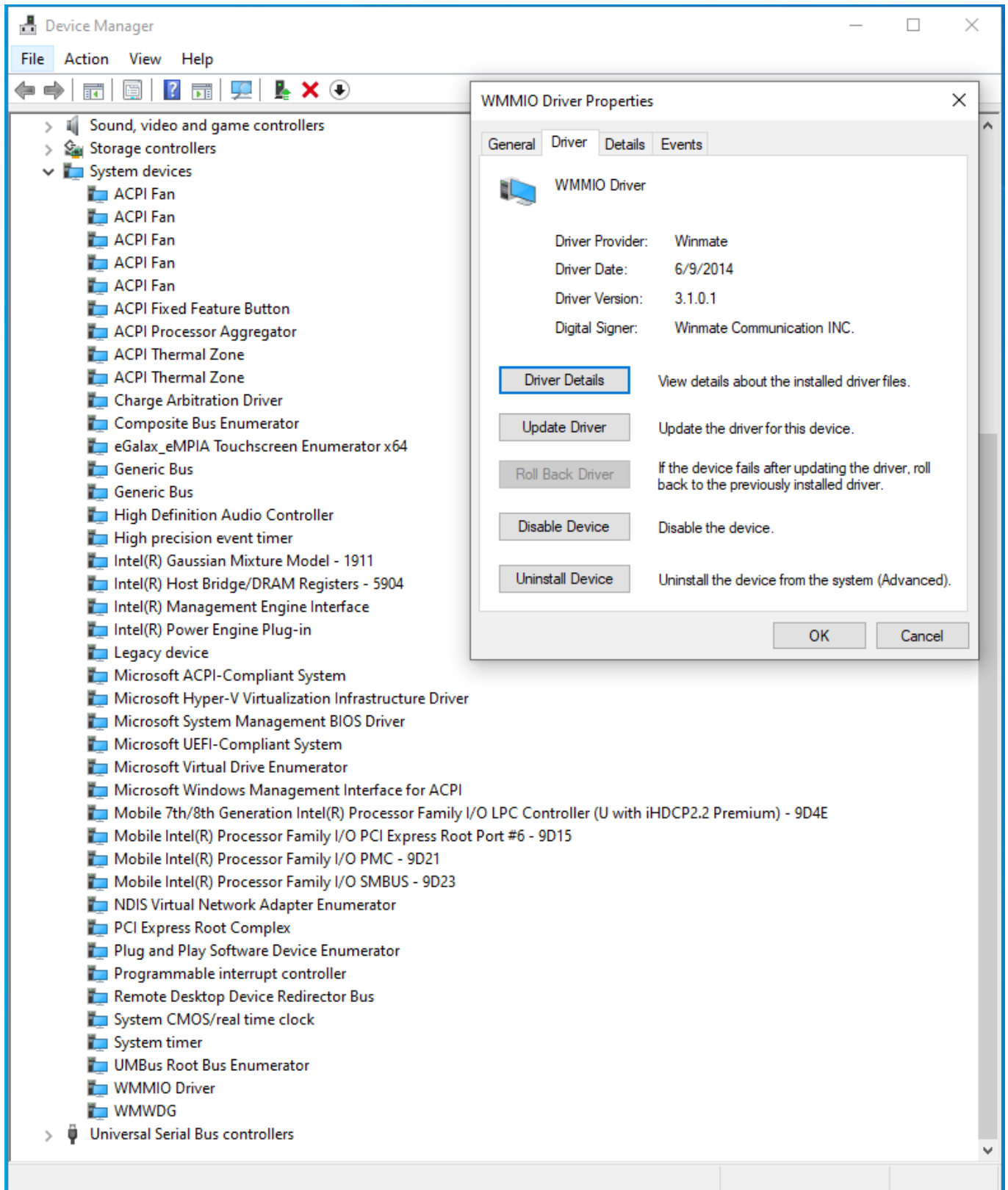

3. Click AP.

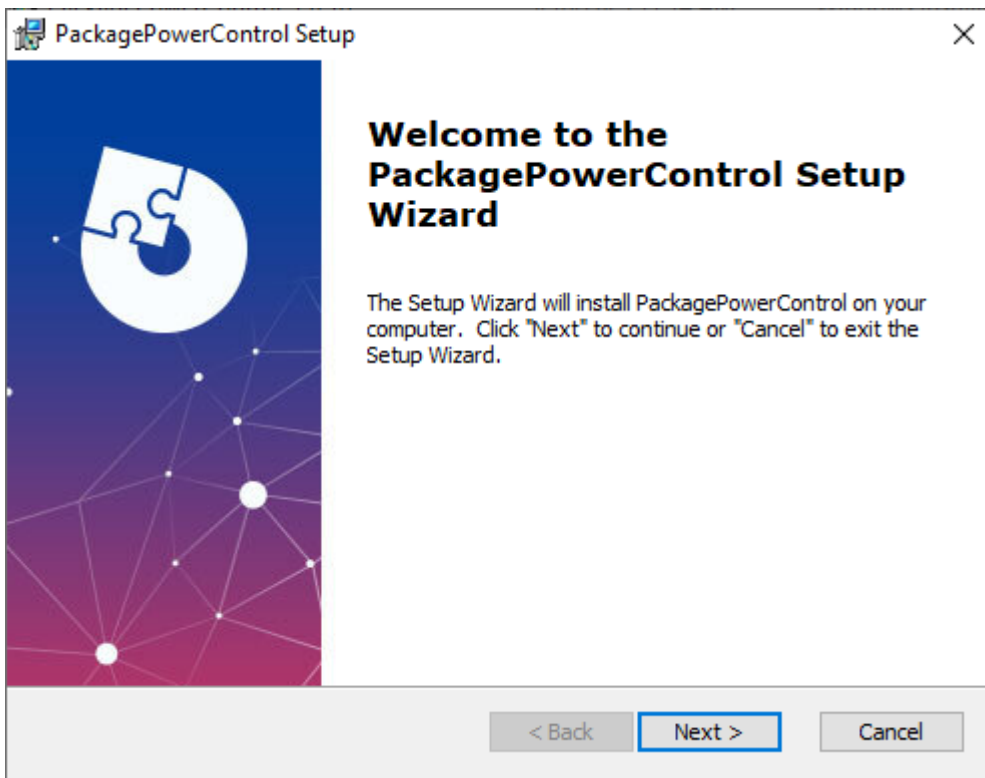
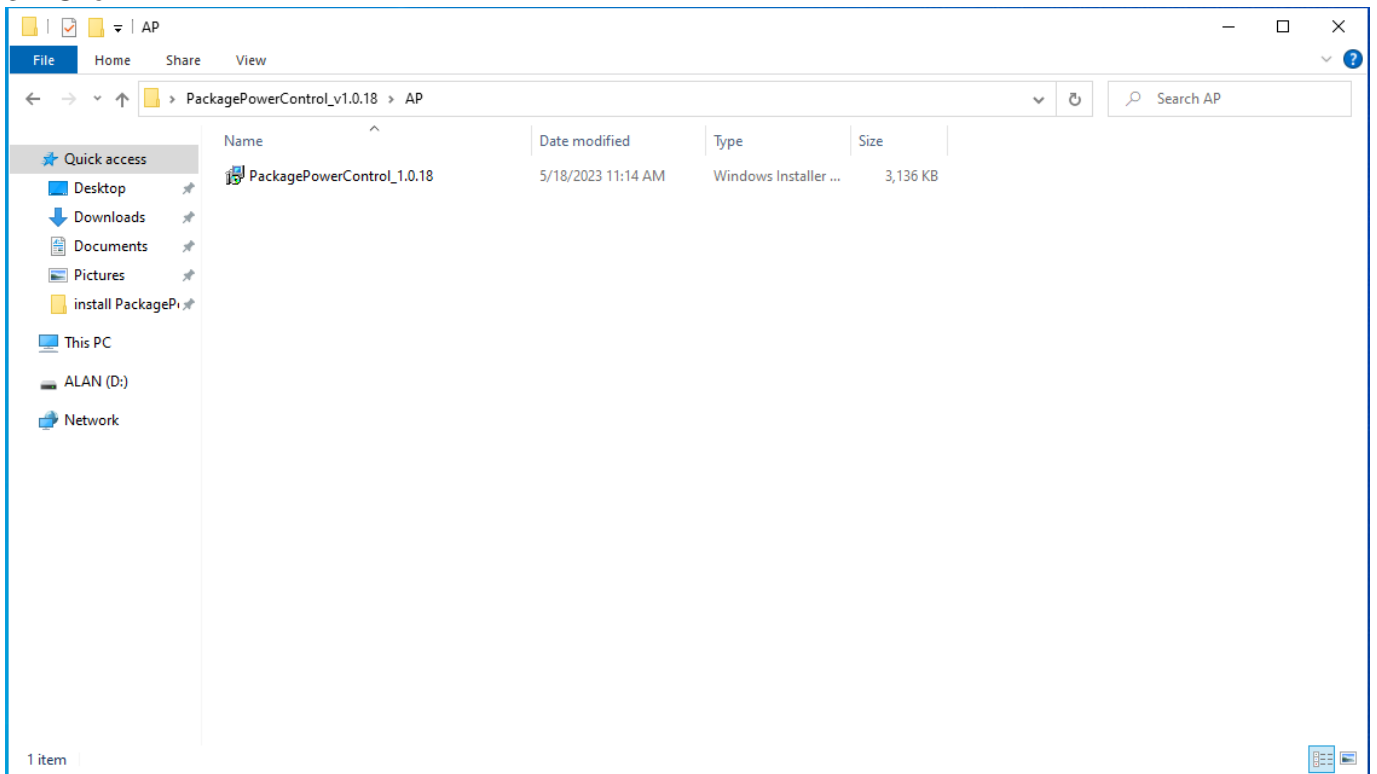

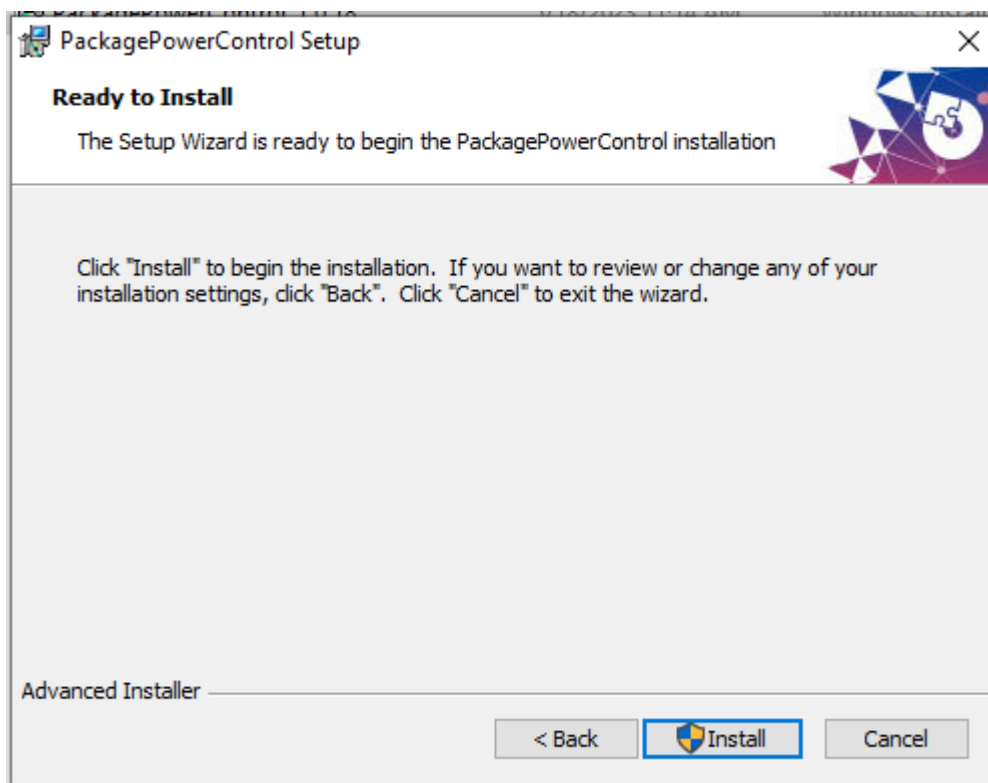
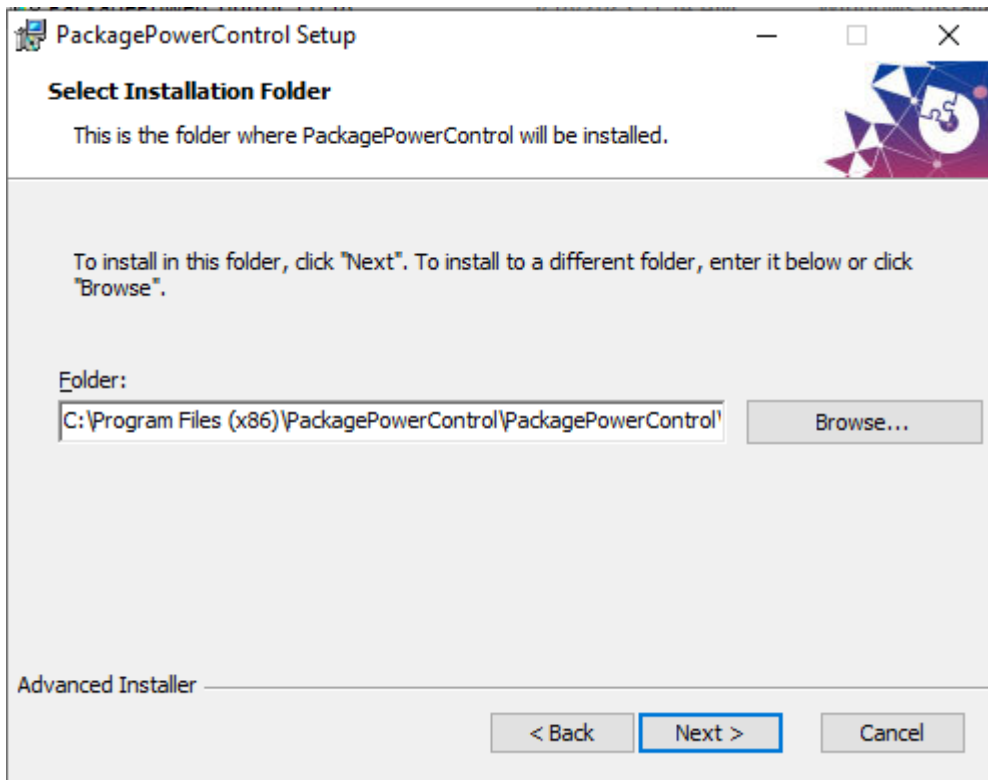

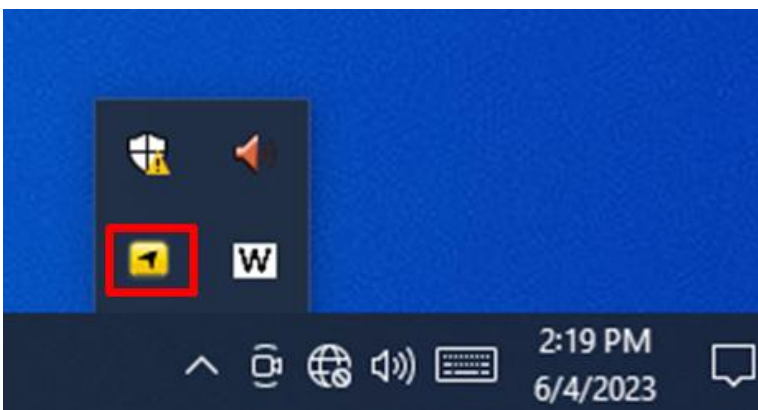
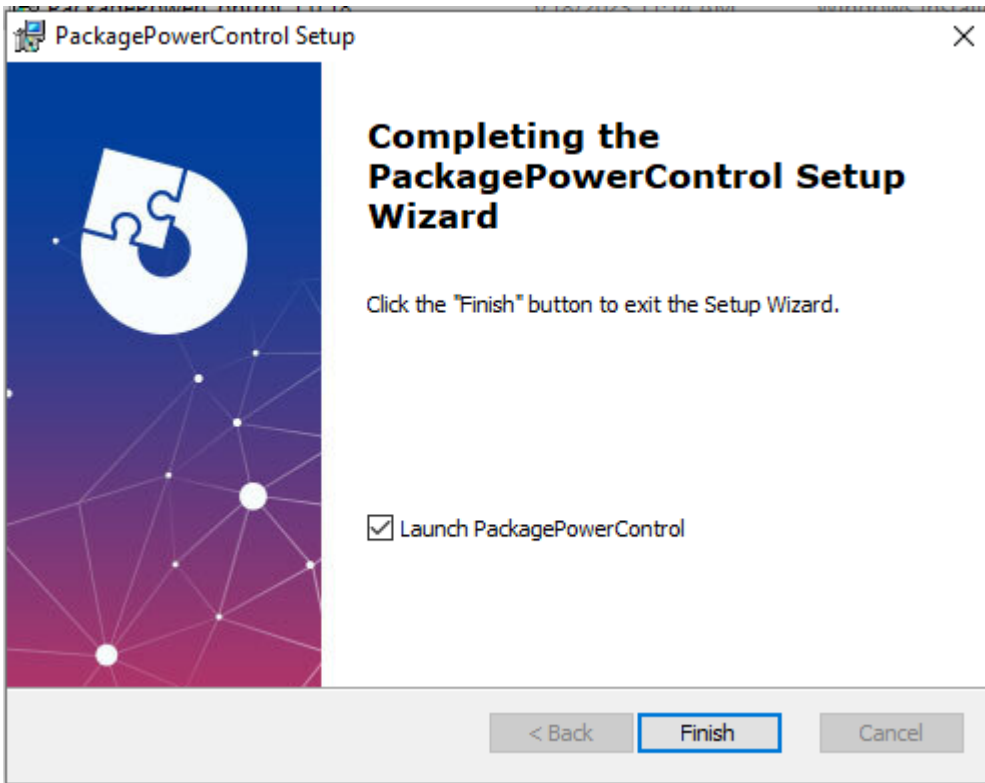

Chapter 4: INSYDE H20 BIOS Setup

This chapter describes the different settings available in the INSYDE BIOS that comes with the board.

- 4.1 How and When to Use BIOS Setup
 - 4.2 BIOS Functions
 - 4.3 Using Recovery Wizard to Restore Computer
 - 4.4 How to Enable Watchdog
-

4.1 How and When to Use BIOS Setup

To enter the BIOS setup, you need to connect an external USB keyboard, external monitor and press Del key when the prompt appears on the screen during start up. The prompt screen shows only few seconds so need press Del key quickly.



IMPORTANT:

Updated BIOS version may be published after the manual released. Check the latest version of BIOS on the website.

You may need to run BIOS setup utility for reasons listed below:

1. Error message on screen indicates to check BIOS setup
2. Restoring the factory default settings.
3. Modifying the specific hardware specifications
4. Necessity to optimize specifications

BIOS Navigation Keys

The following keys are enabled during POST:

Key	Function
Del	Enters the BIOS setup menu.
F7	Display the boot menu. Lists all bootable devices that are connected to the system. With cursor ↑ and cursor ↓ and by pressing <ENTER>, select the device used for the boot.
Pause	Pressing the [Pause] key stops the POST. Press any other key to resume the POST.

The following Keys can be used after entering the BIOS Setup.

Key	Function
F1	Help
F5/ F6	Change Values
F9	Setup Defaults
F10	Save & Exit
Esc	Exit
Enter	Select SubMenu
↑/ ↓	Select Item
← / →	Select Item

For items marked ► press <Enter> for more options.



NOTE:

You can press the F1, F2, F3, F4, -/+, and Esc keys by connecting a USB keyboard to your computer.

4.2 BIOS Functions

4.2.1 Main Menu

The Main menu displays the basic information about your system including BIOS version, processor RC version, system language, time, and date.

When you enter BIOS setup, the first menu that appears on the screen is the main menu. It contains the system information including BIOS version, processor RC version, system language, time, and date.

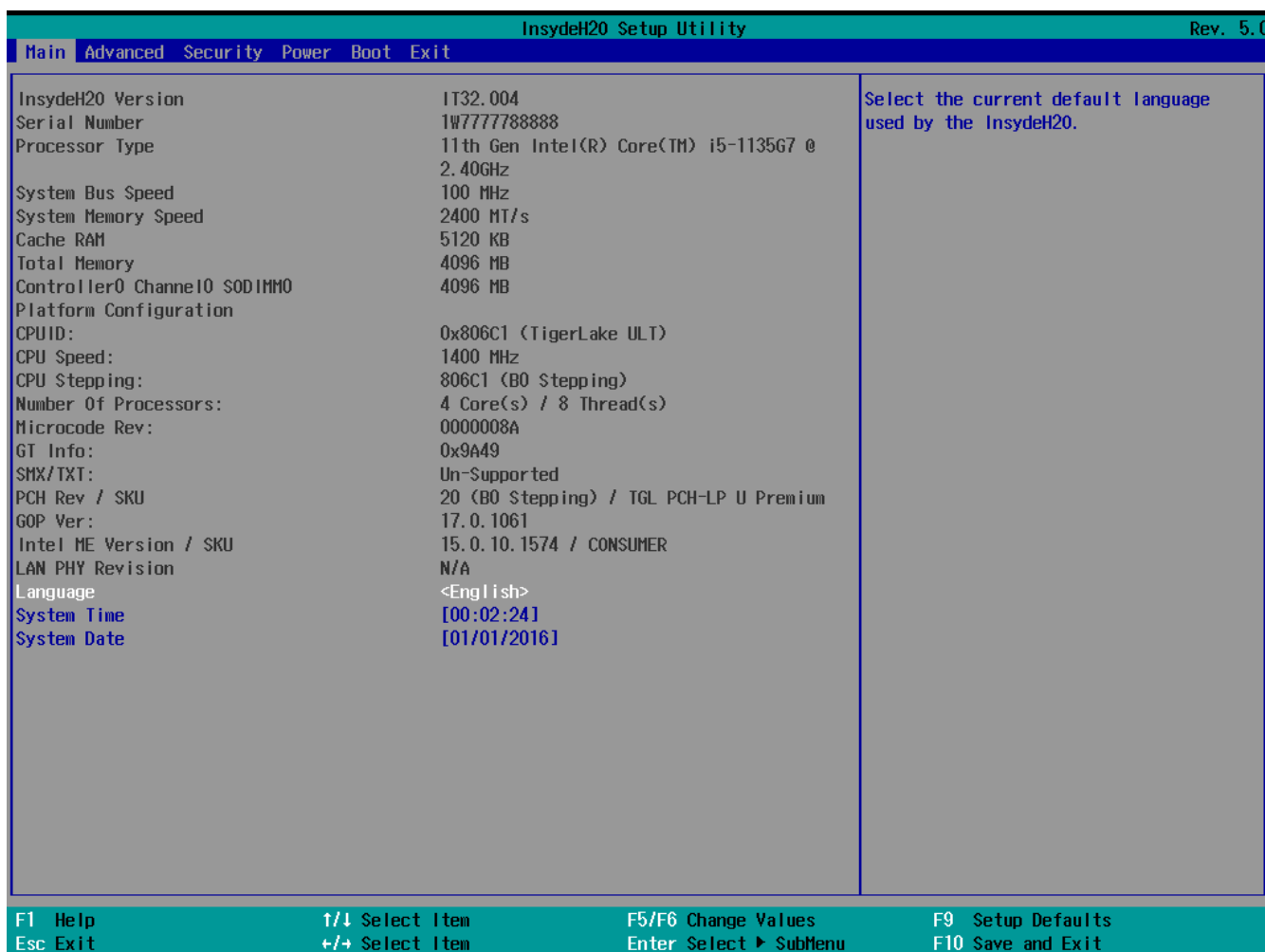

BIOS Setting	Description	Setting Option	Effect
Language	Displays the system language. [English] is set up by default.	Adjustment of the language	Set the language in other language. The language in this device is English.
System Time	This is current time setting. The time is maintained by the battery when the device is turned off.	Date and time changes.	Set the time in the format: [hh/mm/ss]
System Date	This is current date setting.	Date and time changes.	Set the date in the format [mm/dd/yyyy];

4.2.2 Advanced

Select the Advanced Tab from the setup menu to enter the advanced BIOS setup screen. You can select any of the items on the left frame of the screen to go to the sub menu for the item, such as CPU Configuration. You can use the <Arrow> keys enter all advanced BIOS setup options. The advanced BIOS setup menu is shown below. The submenus described on the following pages.



CAUTION

Handle advanced BIOS settings page with caution. Any changes can affect the operation of your computer.

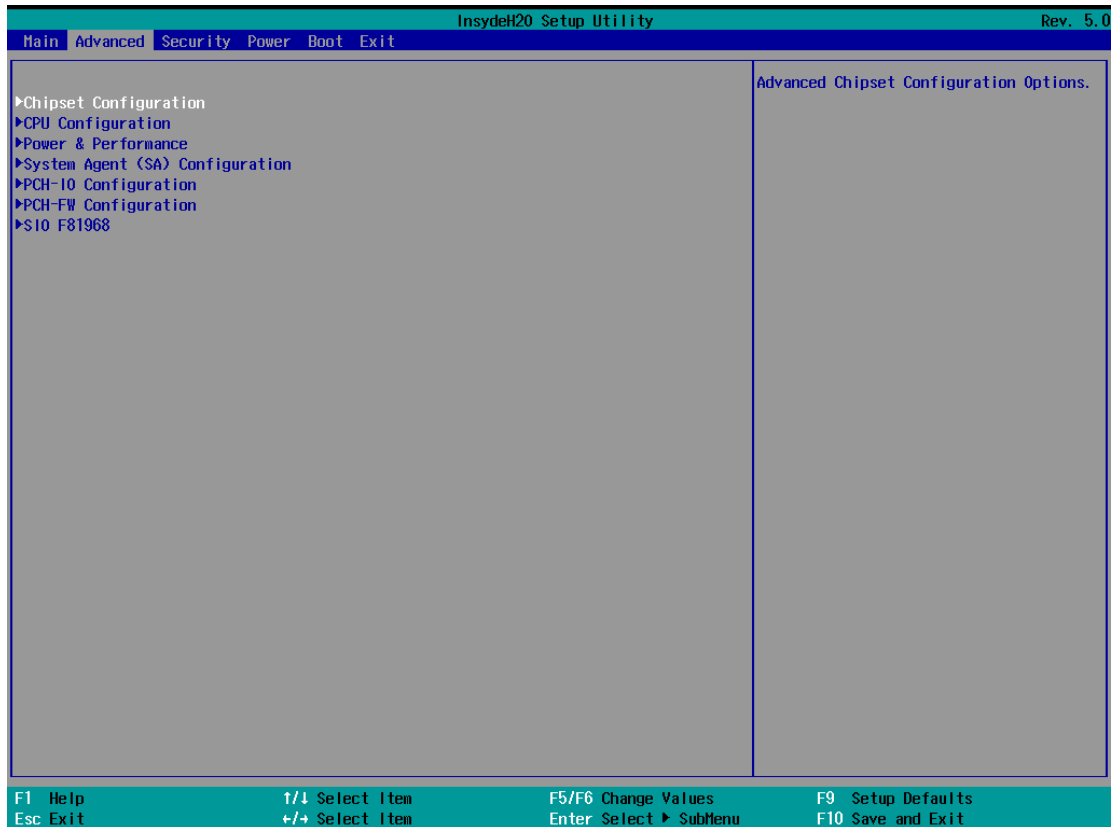

BIOS Setting	Description	Setting Option	Effect
CPU Configuration	Configures Trusted Computing parameters	Enter	Opens submenu
Power & Performance	Configures Power & Performance parameters	Enter	Opens submenu
System Agent Configuration	Configures System Agent Configuration parameters	Enter	Opens submenu
PCH-OI Configuration	Configures PCH-OI parameters	Enter	Opens submenu
PCH-FM Configuration	Configures PCH-FM parameters	Enter	Opens submenu
SIO F81968	Configures SIO F81968 parameters	Enter	Opens submenu
Console Redirection	Configures Console Redirection parameters	Enter	Opens submenu

4.2.2.1 CPU Configuration

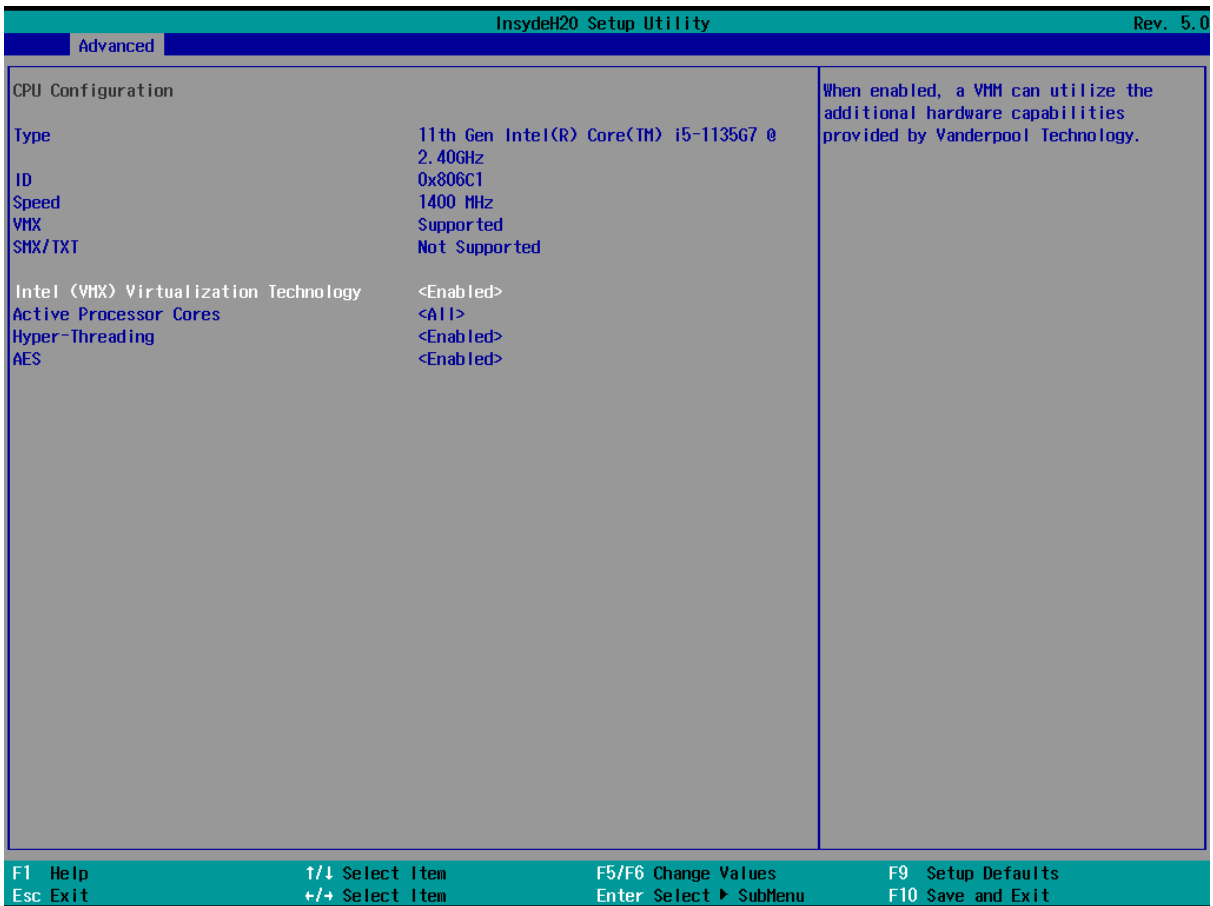

BIOS Setting	Description	Setting Option	Effect
Intel (VMM) Virtualization Technology.	Enable or disable Intel Virtualization Technology.	Enable/Disable	When enabled, a VMM can utilized the additional hardware capabilities provided by Vanderpool Technology.
Active Processor Cores	Number of cores to enable in each processor package	All / 1 / 2 / 3	Select number of cores to enable in each processor package
AES	Enable or disable AES (Advanced Encryption Standard)	Enable/Disable	Enable or disable AES

4.2.2.2 Power & Performance

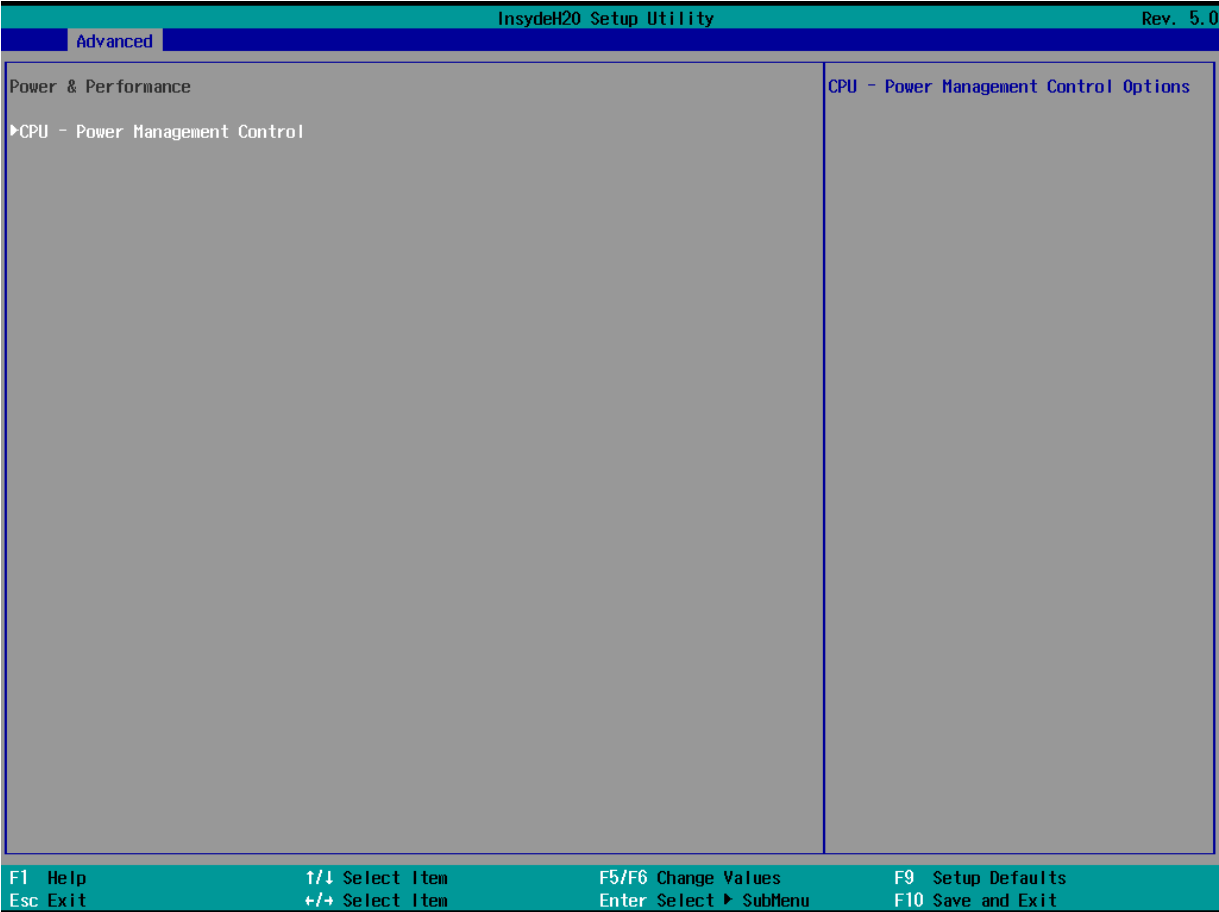

BIOS Setting	Description	Setting Option	Effect
CPU – Power Management Control	Configure CPU – Power Management Control parameters	Enter	Enters sub-menu

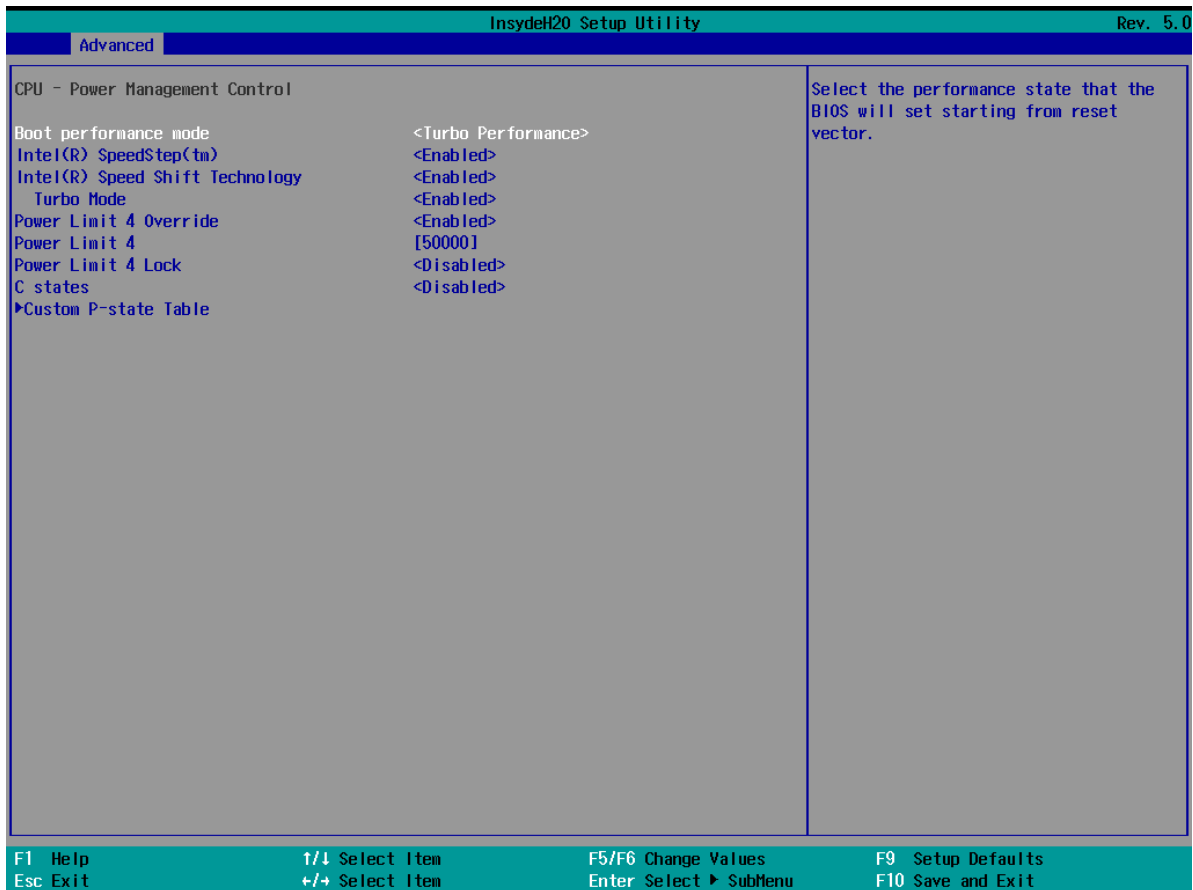

BIOS Setting	Description	Setting Option	Effect
Boot Performance Mode	Configure Boot Performance Mode parameters	- Max non-turbo performance - Max battery - Turbo Performance	Enters sub-menu
Intel SpeedStep (ta)	Configure Intel SpeedStep (ta) parameters	Enabled/ Disabled	Allows more than two frequency ranges to be supported
Intel Speed Shift Technology	Configure Intel Speed Shift Technology parameters	Enabled/ Disabled	Enable/ Disable Intel Speed Shift Technology support. Enabling will expose the CPP v2 interface to allow for hardware-controlled P-states
-Turbo Mode	Enable or disable Turbo Mode	Enabled/ Disabled	Enable/ Disable processor Turbo Mode (requires EMTTM enabled too). Auto means enabled, unless max turbo ratio is bigger than 16 – SKL AO W/A

4.2.2.2.1 How to Enable/Disable Turbo Mode

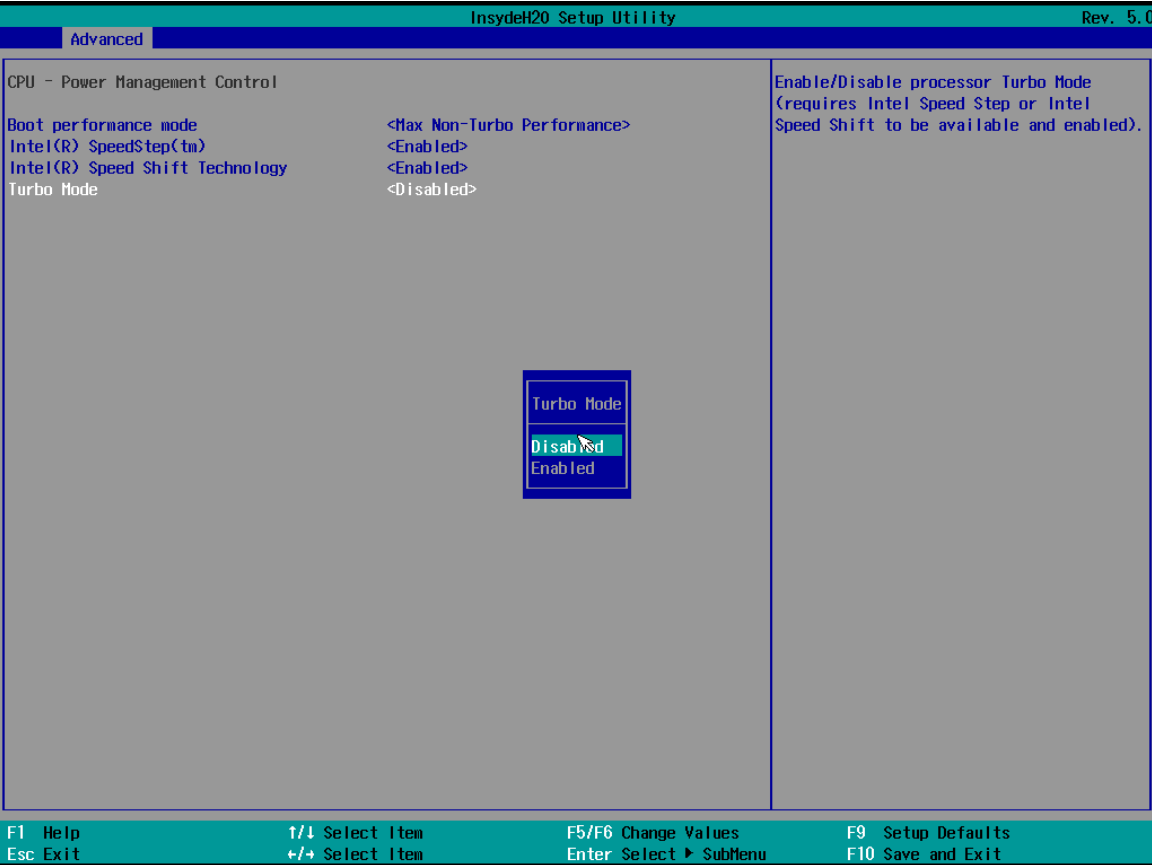

4.2.2.3 System Agent (SA) Configuration

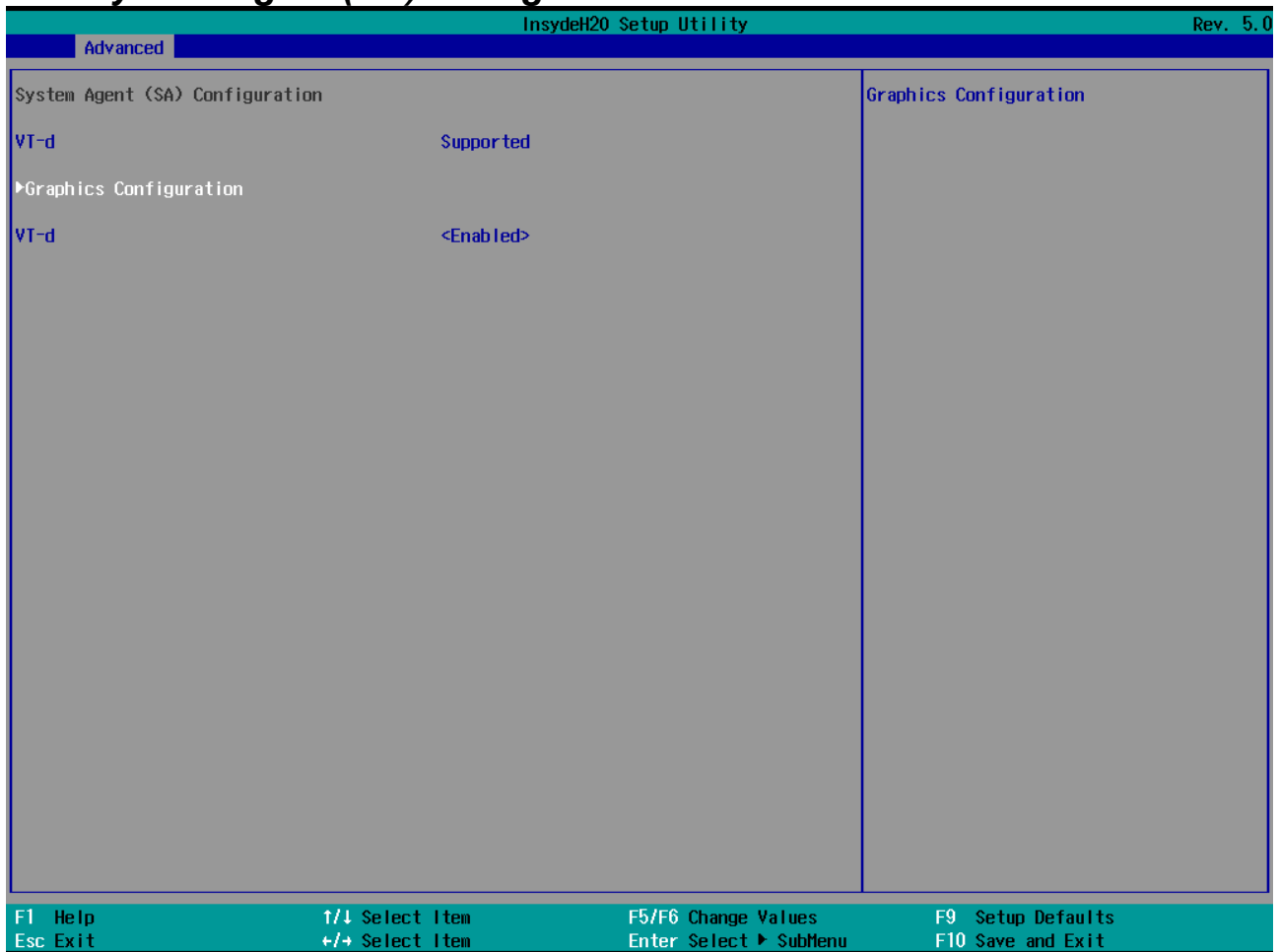

BIOS Setting	Description	Setting Option	Effect
Graphics Configuration	Configure Graphics Configuration parameters	Enter	Opens sub-menu
PEG Port Configuration	Configure PEG Port Configuration parameters	Enter	Opens sub-menu
Vt-d	Intel® Virtualization Technology for Directed I/O	Enabled Disabled	Vt-d capability

4.2.2.3.1 Graphics Configuration

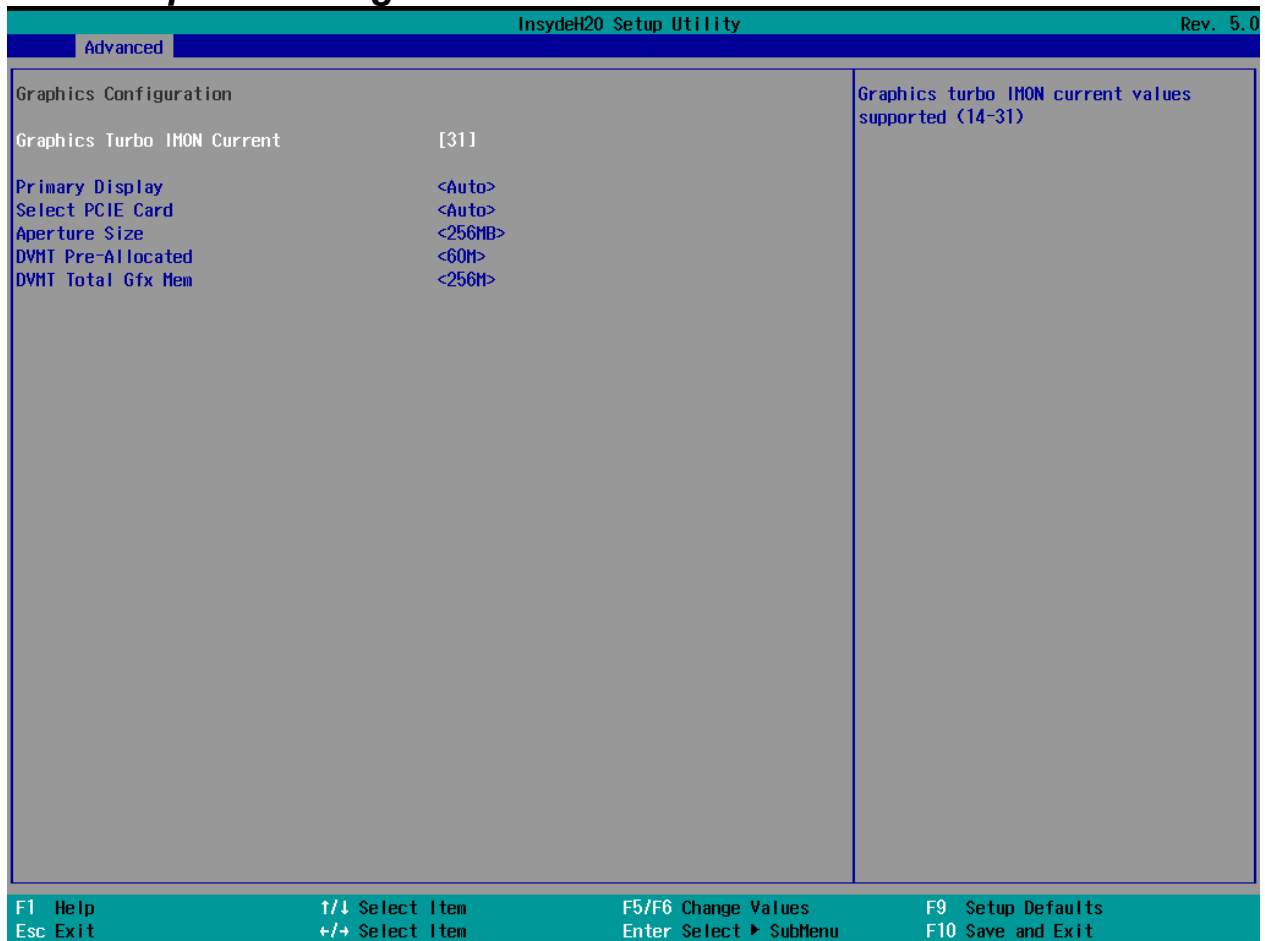

BIOS Setting	Description	Setting Option	Effect
Graphics Turbo IMON Current	Graphics Turbo IMON Current values supported	14-31	Select Graphics Turbo IMON Current values supported
Primary Display	Select Primary Display	Auto IGFX PEG PCI	Select which of IGFX/PEG/ PCI Graphics device should be primary display or select SG for Switchable Gfx
Aperture Size	Select the aperture size	128MB 256MB 512MB 1024MB 2048 MB	Select the aperture size Note: Above 4MB MMIO BIOS assignment is automatically enabled when selecting 2048MB aperture. To use this feature please disable CSM port
DVMT Pre-Allocated	Select DVMT Pre-Allocated	0M~60M	Select DVMT 5.0 Pre-Allocated (Fixed) Graphic Memory size used by Internal Graphic Device
DVMT Total Gfx Mem	Select DVMT Total Gfx Mem	256M 128M MAX	Select DVMT 5.0 Total Graphic Memory size used by the Internal Graphic Device

4.2.2.3.2 VT-d

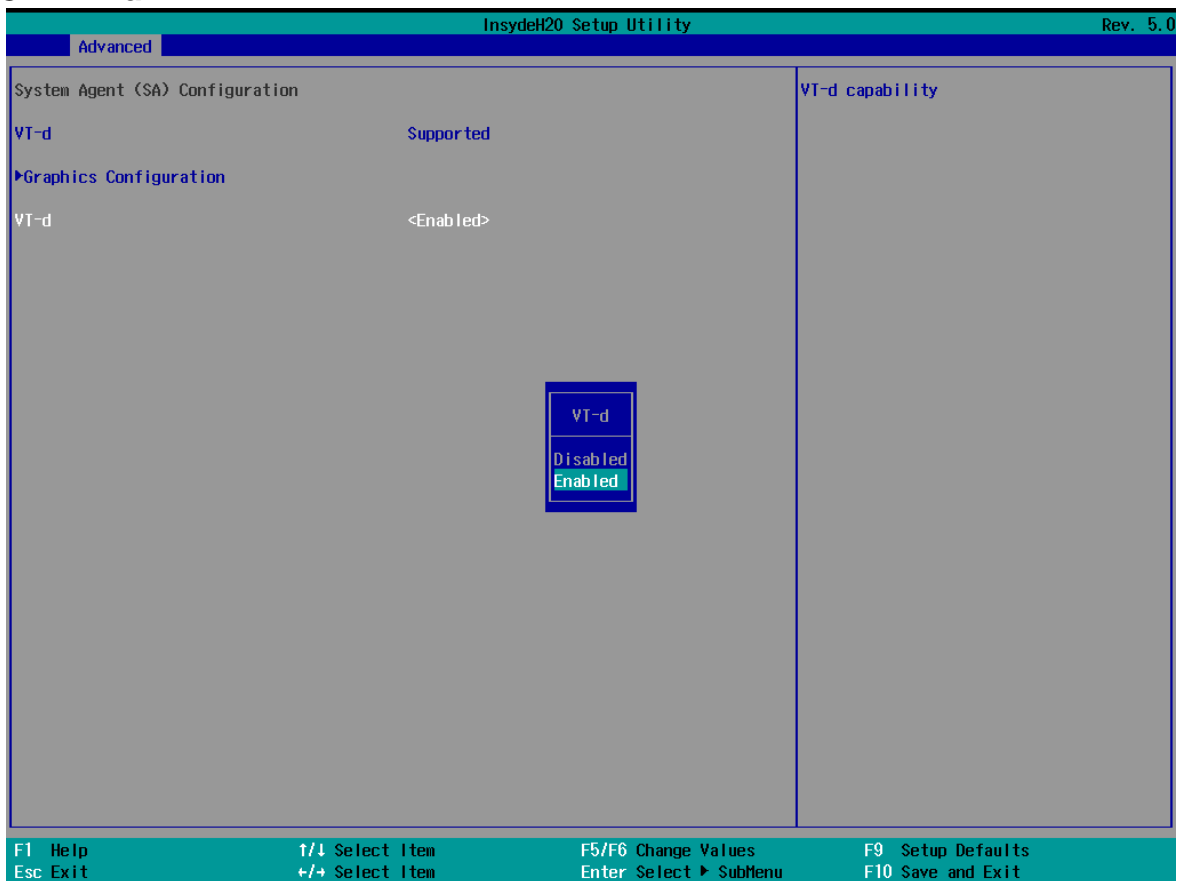

BIOS Setting	Description	Setting Option	Effect
VT-d	Intel® Virtualization Technology for Directed I/O	Enabled Disabled	Vt-d capability

4.2.2.4 PCH-IO Configuration

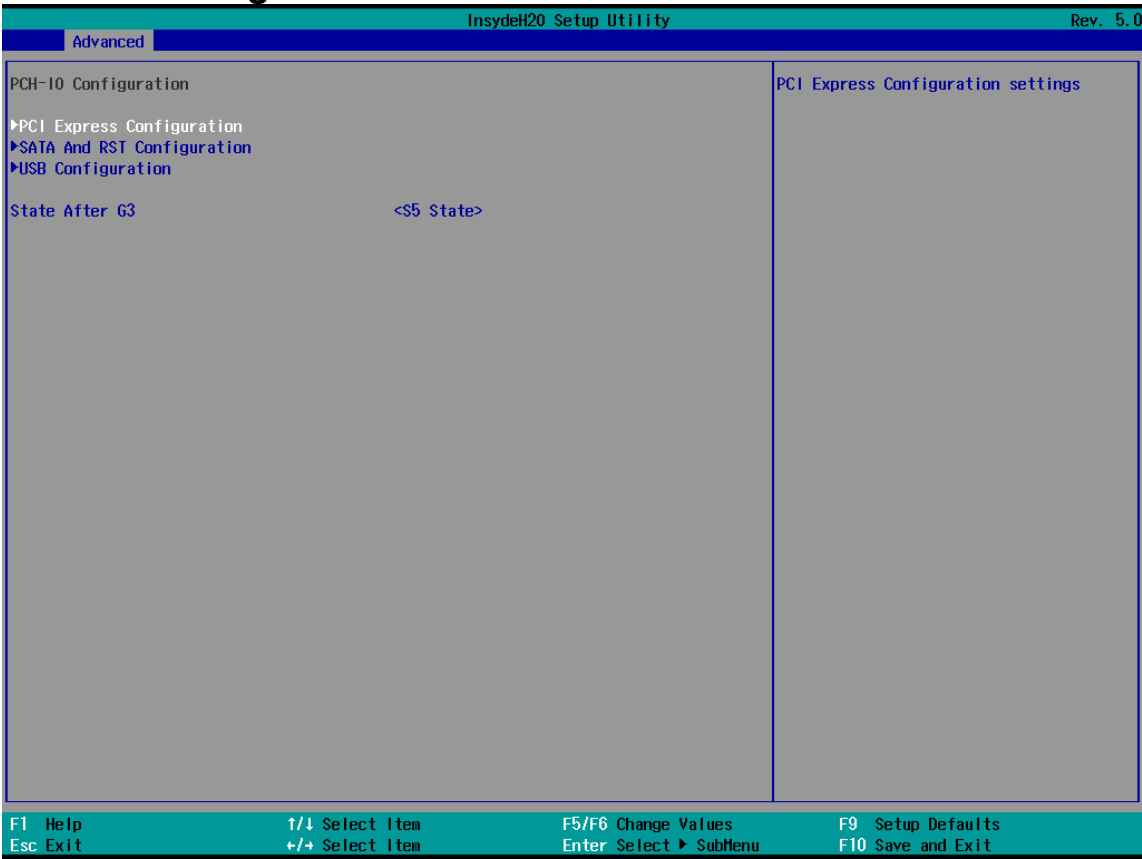

BIOS Setting	Description	Setting Option	Effect
PCI Express Configuration	Configure PCI Express settings	Enter	Opens sub-menu
SATA And RST Configuration	Configure SATA And RST settings	Enter	Opens sub-menu
USB Configuration	Configure USB settings	Enter	Opens sub-menu
State After G3			S0 = auto power on after power failure S5 = keep power off after power failure

4.2.2.4.1 PCI Express Configuration

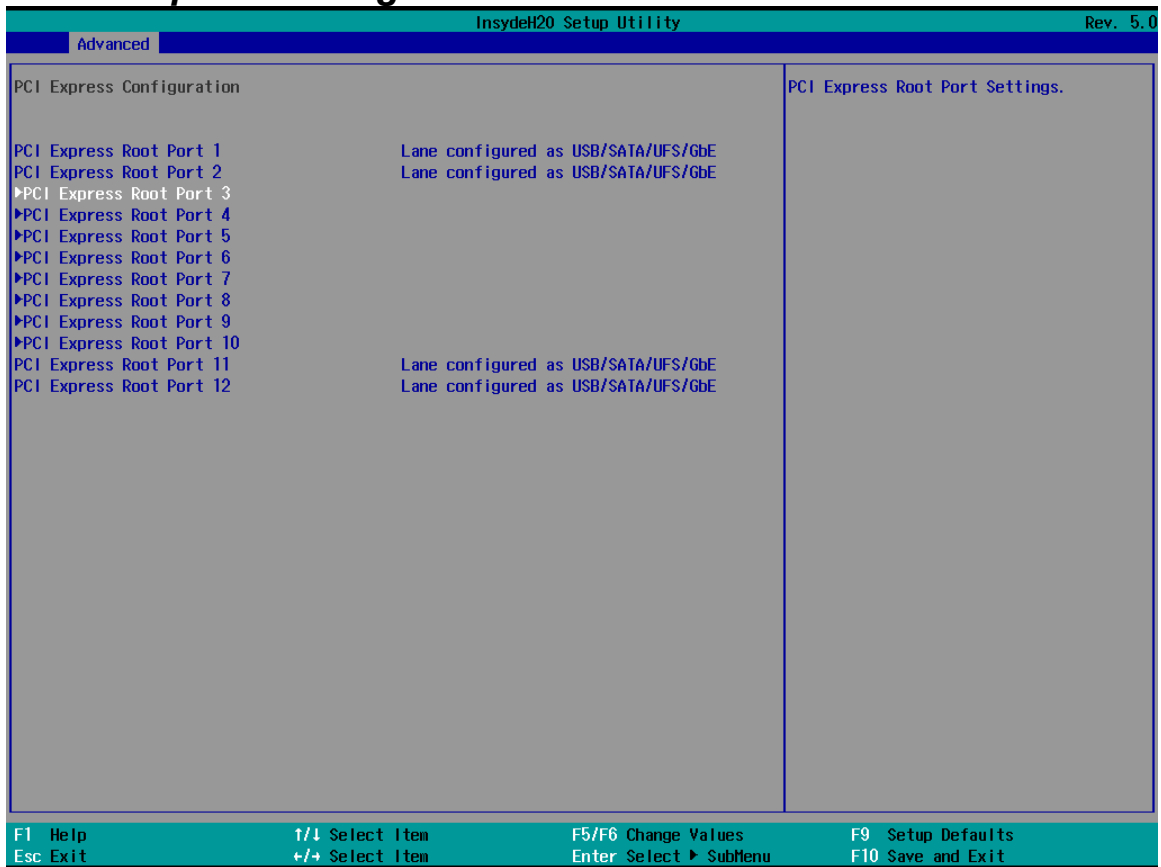

BIOS Setting	Description	Setting Option	Effect
PCI Express Clock Gating	PCI Express Clock Gating settings	Enabled Disabled	PCI Express Clock Gating Enable/ Disable for each root port
PCI Port assigned to LAN	PCI Port assigned to LAN settings	Value	Choose value
PCI Express Root Port 5	Control the PCI Express Root Port 5	Enter	Opens sub-menu

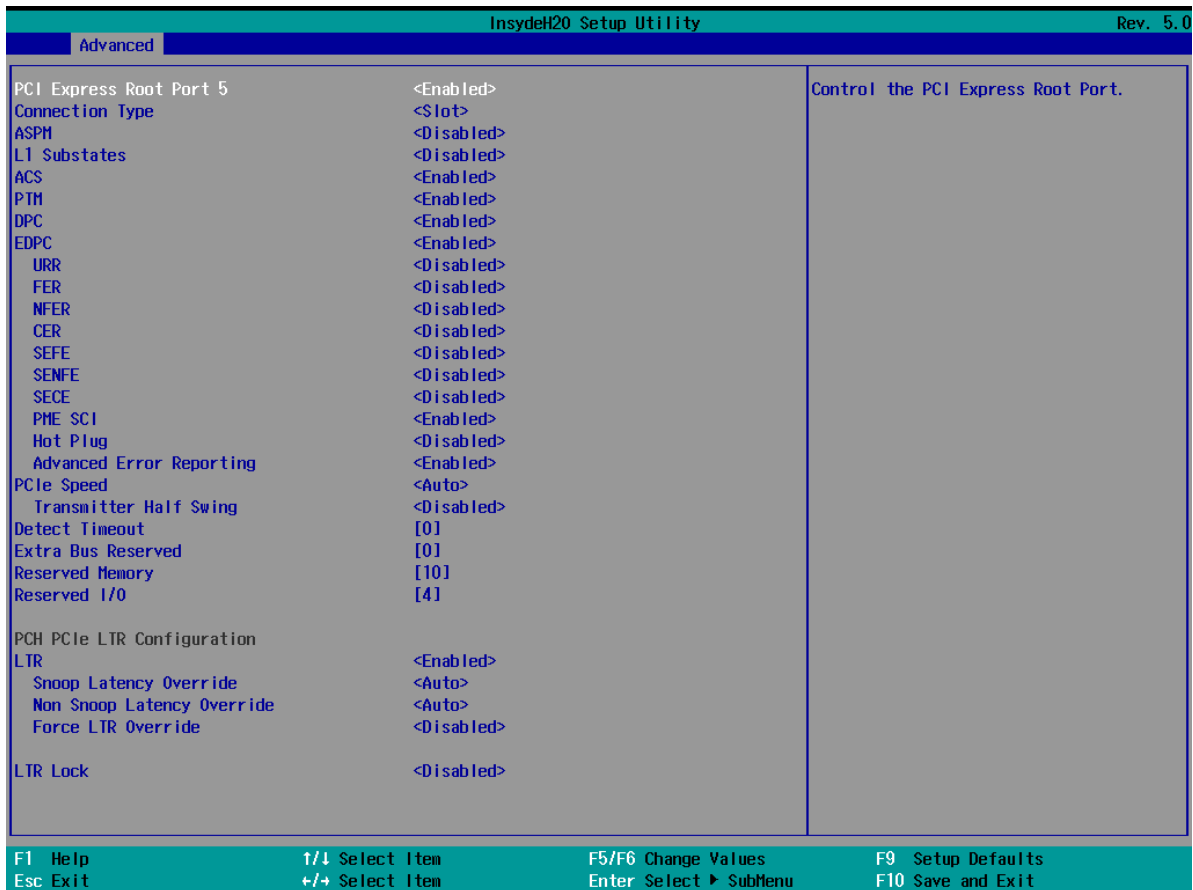

BIOS Setting	Description	Setting Option	Effect
PCI Express Root Port 5	Control the PCI Express Root Port 5	Enter	Opens sub-menu
Topology	Topology settings	Unknown x1 x4 SATA Express M2	Identify the SATA Topology if it is Default or ISATA or Flex or Direct Connect or M2
ASPM	ASPM settings	Auto L0sL1 L1 L0s Disabled	Automatically enable ASPM based on reported capabilities and known issues
L1 Substrates	PCIE Express L1 Substrates settings	Disabled L1.1 L1.2 L1.1 & L1.2	PCIE Express L1 Substrates settings
Gen3 Eq Phase3 Method	Gen3 Eq Phase3 Method settings	Hardware Static Coefic Software Search	PCIe Gen3 Equalization Phase 3 Method
ACS	Access Control Services Extended Capability settings	Disabled Enabled	Enable/ Disable Access Control Services Extended Capability

PCIe Speed	Configure PCIe Speed	Auto Gen1 Gen2 Gen3	Configure PCIe Speed
PCH PCIE4 LTR	PCH PCI Latency Reporting Enable/ Disable	Disabled Enabled	PCH PCI Latency Reporting Enable/ Disable
PCIE4 LTR Lock	PCIE4 LTR Lock settings	Disabled Enabled	PCIE4 LTR Configuration Lock
PCIE4 CLKREQ Mapping Override	PCIE4 CLKREQ Mapping Override	Default No CLKREQ Custom Number	PCIE4 CLKREQ Mapping Override for default platform mapping

4.2.2.4.2 SATA and RST Configuration

InsydeH20 Setup Utility Rev. 5.0

Advanced

SATA And RST Configuration

SATA Controller(s) <Enabled>

SATA Mode Selection <AHCI>

Serial ATA Port 0 Empty

Software Preserve Unknown

Port 0 <Enabled>

Hot Plug <Disabled>

Configured as eSATA Hot Plug supported

External <Disabled>

Spin Up Device <Disabled>

SATA Device Type <Hard Disk Drive>

Topology <Unknown>

SATA Port 0 DevSlp <Disabled>

DITO Configuration <Disabled>

DITO Value [625]

DM Value [15]

Serial ATA Port 1 ADATA_IM2S3164 (256.0GB)

Software Preserve SUPPORTED

Port 1 <Enabled>

Hot Plug <Disabled>

Configured as eSATA Hot Plug supported

External <Disabled>

Spin Up Device <Disabled>

SATA Device Type <Hard Disk Drive>

Topology <Unknown>

SATA Port 1 DevSlp <Disabled>

DITO Configuration <Disabled>

DITO Value [625]

DM Value [15]

Serial ATA Port 2 Empty

Software Preserve Unknown

Port 2 <Enabled>

Enable/Disable SATA Device.

F1 Help ↑/↓ Select Item F5/F6 Change Values F9 Setup Defaults
Esc Exit +/- Select Item Enter Select ► SubMenu F10 Save and Exit

4.2.2.4.3 USB Configuration

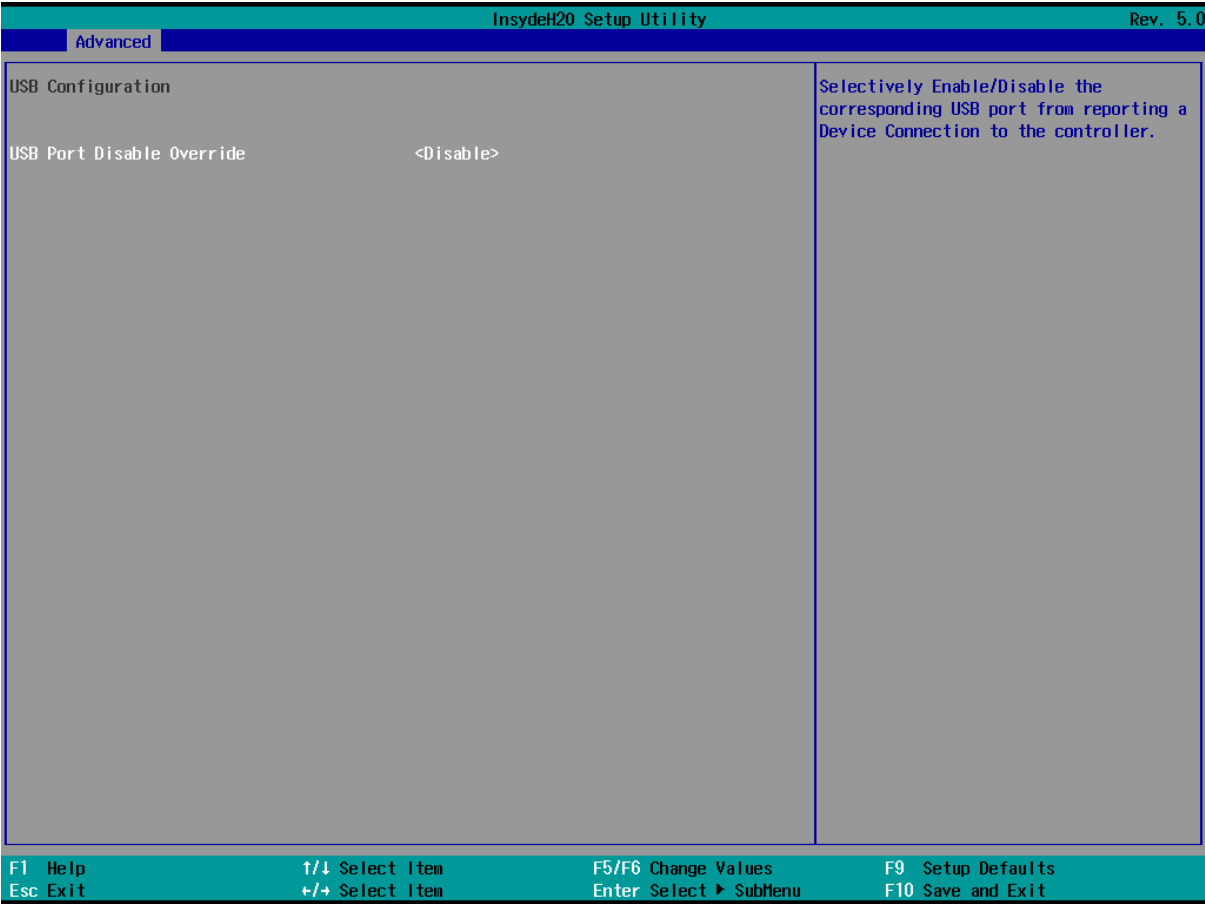

BIOS Setting	Description	Setting Option	Effect
USB Port Disable Override	USB Port Disable Override configuration	Disable Select Per-Pin	Selectively Enable/ Disable the corresponding USB port from reporting a Device Connection to the controller

4.2.2.4.4 State After G3

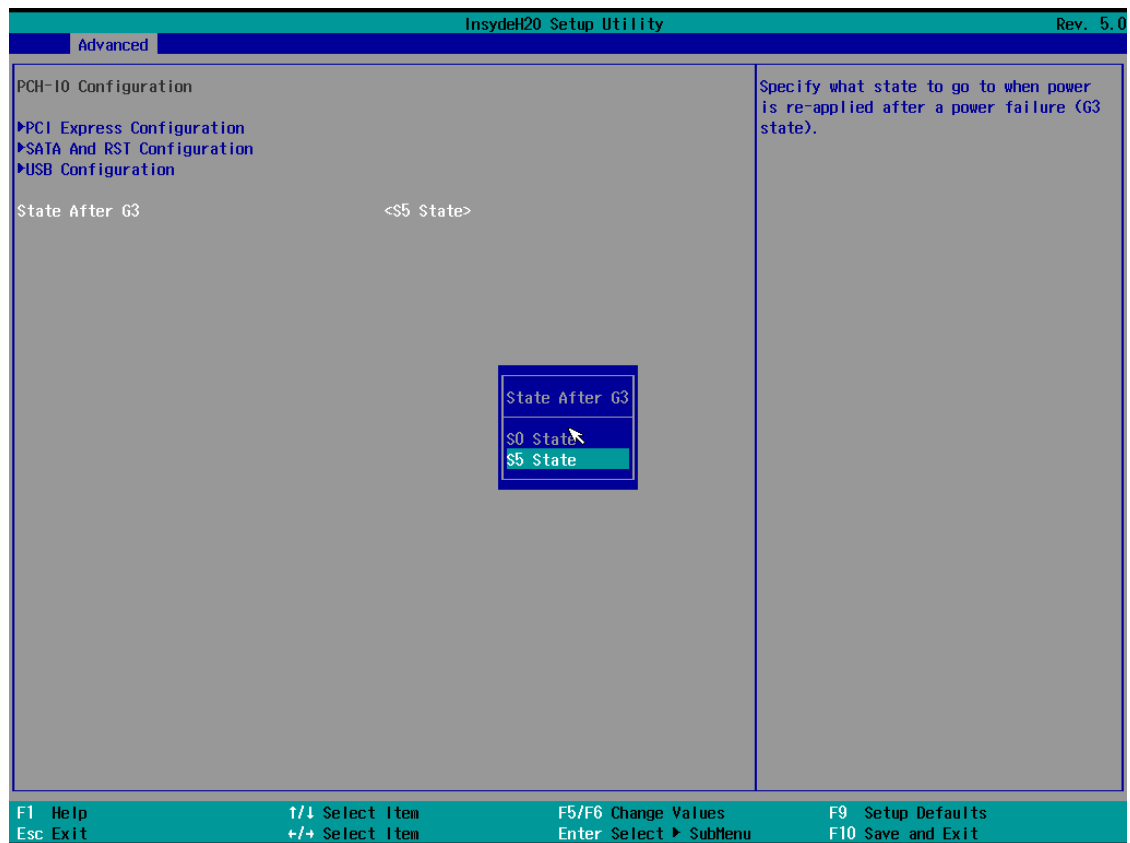

BIOS Setting	Description	Setting Option	Effect
State After G3	State After G3 configuration	S0 State S5 State	Specify what state to go to when power is re-applied after a power failure (G3 state)

4.2.2.5 PCH-FW Configuration

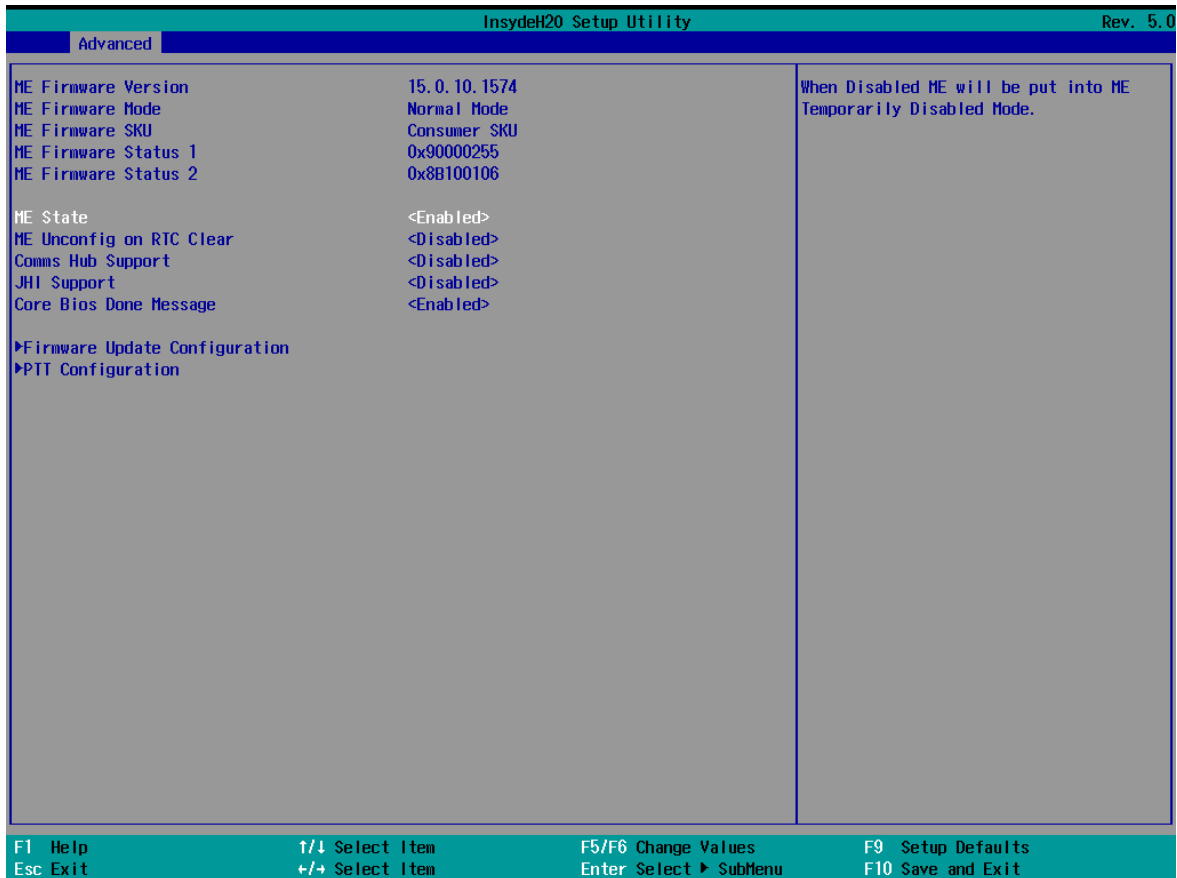

BIOS Setting	Description	Setting Option	Effect
ME State	ME State configuration	Disabled Enabled	When Disabled ME will be put into ME Temporarily Disabled Mode
Manageability Features State	Manageability Features State configuration	Disabled Enabled	Enable/ Disable Intel Manageability Features Note: this option disabled/ enables Manageability Features support in FW. To disable support platform must be in an unprovisioned state first.
AMT BIOS Features	AMT BIOS Features	Disabled Enabled	Enable/ Disable Intel Active Management Technology BIOS Extension. Note: iAMT H/W Is always enabled. This option just controls the BIOS Extension execution.
AMT Configuration	AMT Configuration	Enter	Opens sub-menu
ME Unconfig on RTC Clear State	ME Unconfig on RTC Clear State	Disabled Enabled	Disabling this option will cause ME not to unconfigure on RST clear
Comms Hub Support	Comms Hub Support	Disabled Enabled	Enable/Disable support for Comms Hub

JHI Support	JHI Support	Disabled Enabled	Enable/Disable Intel DAL Host Interface Service (JHI)
Core BIOS Done Message	Core BIOS Done Message	Disabled Enabled	Enable /Disable Core BIOS Done message sent to ME
Firmware Update Configuration	Firmware Update Configuration	Enter	Opens sub-menu
PTT Configuration		Enter	Opens sub-menu
ME Debug Configuration			

4.2.2.6 SIO F81968

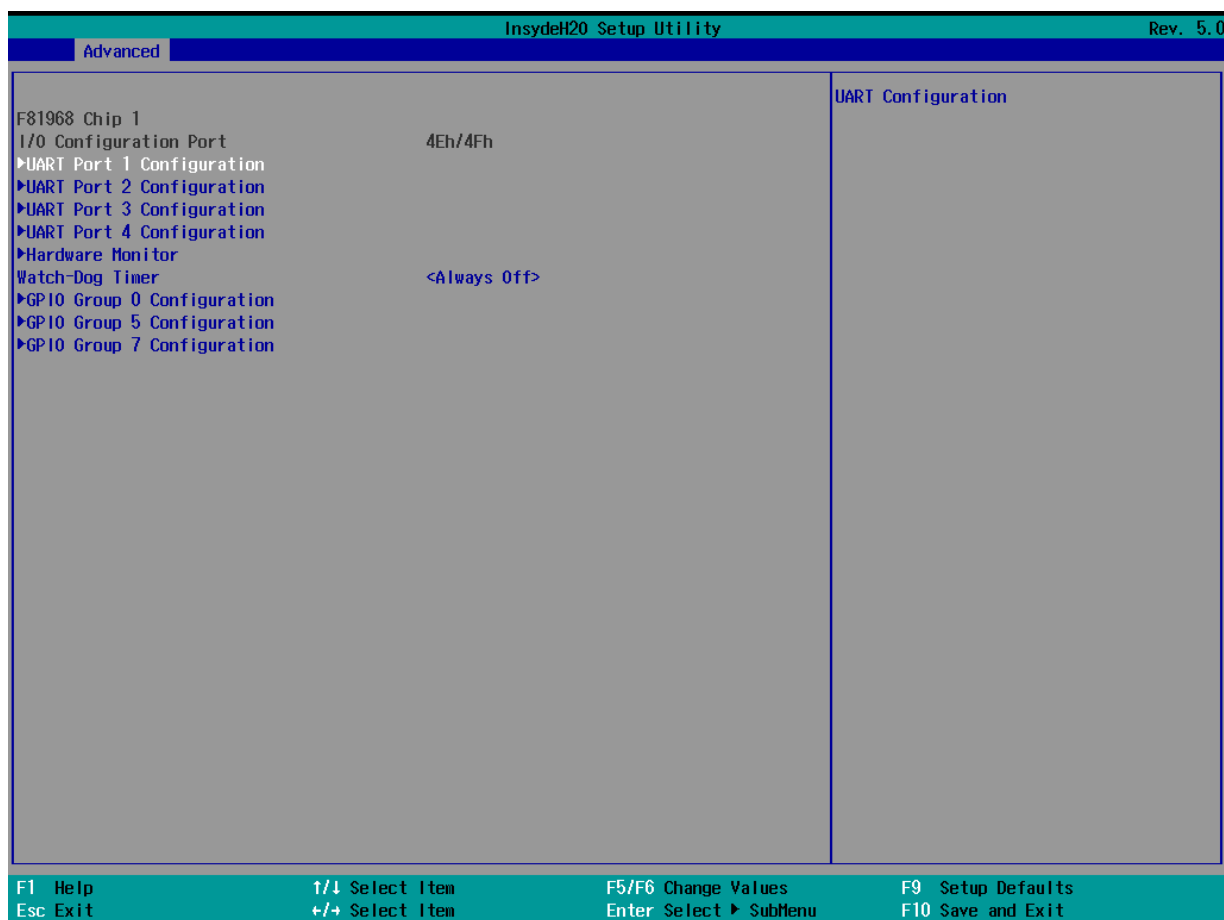

BIOS Setting	Description	Setting Option	Effect
UART Port 1 ~ UART Port 4	Configure Serial port settings	Disable	No configuration
		Enable	User configuration
		Auto	EFI/OS chooses configuration
WDT	Watchdog Timer configuration	Disable Enable	Enable or disable Watchdog Timer
Hardware Monitor	Hardware Monitor	Enter	Opens sub-section
GPIO Group 0 Configuration	GPIO Group 0 Configuration	Enter	Opens sub-section

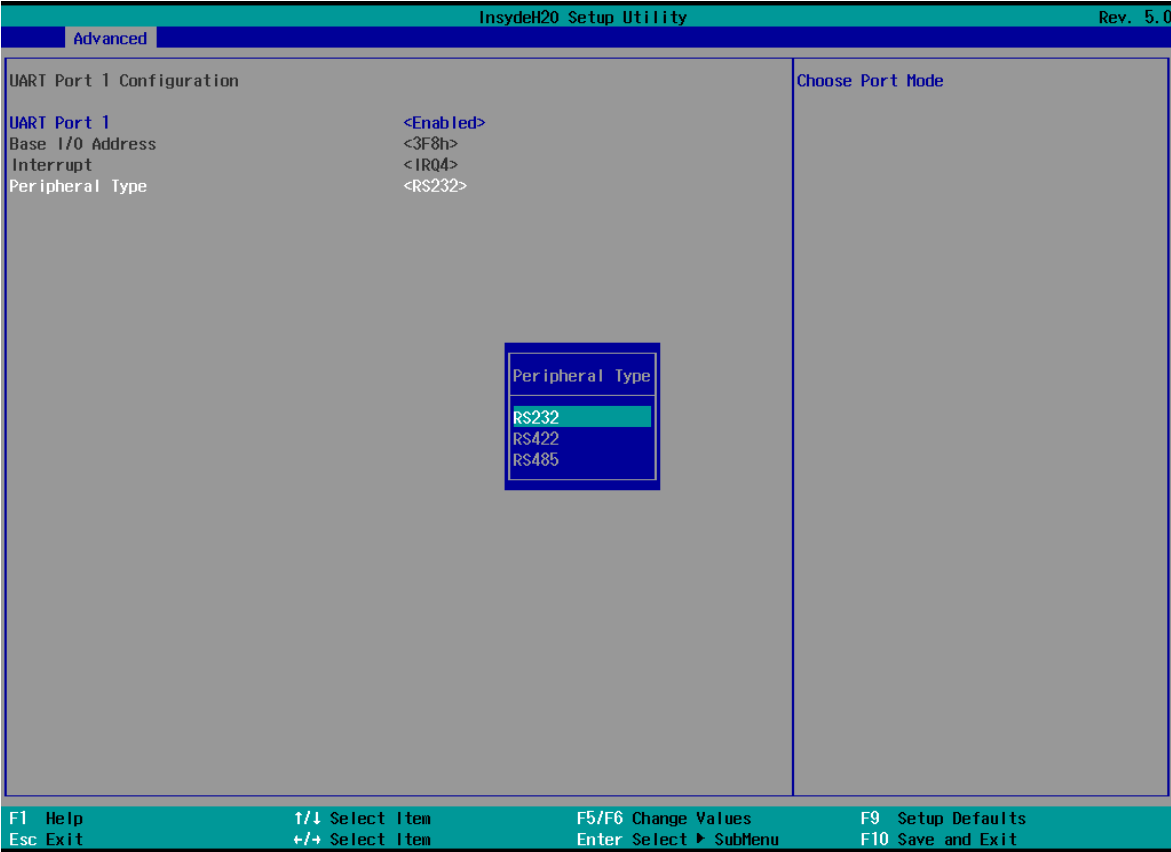

4.2.2.6.1 Hardware Monitor

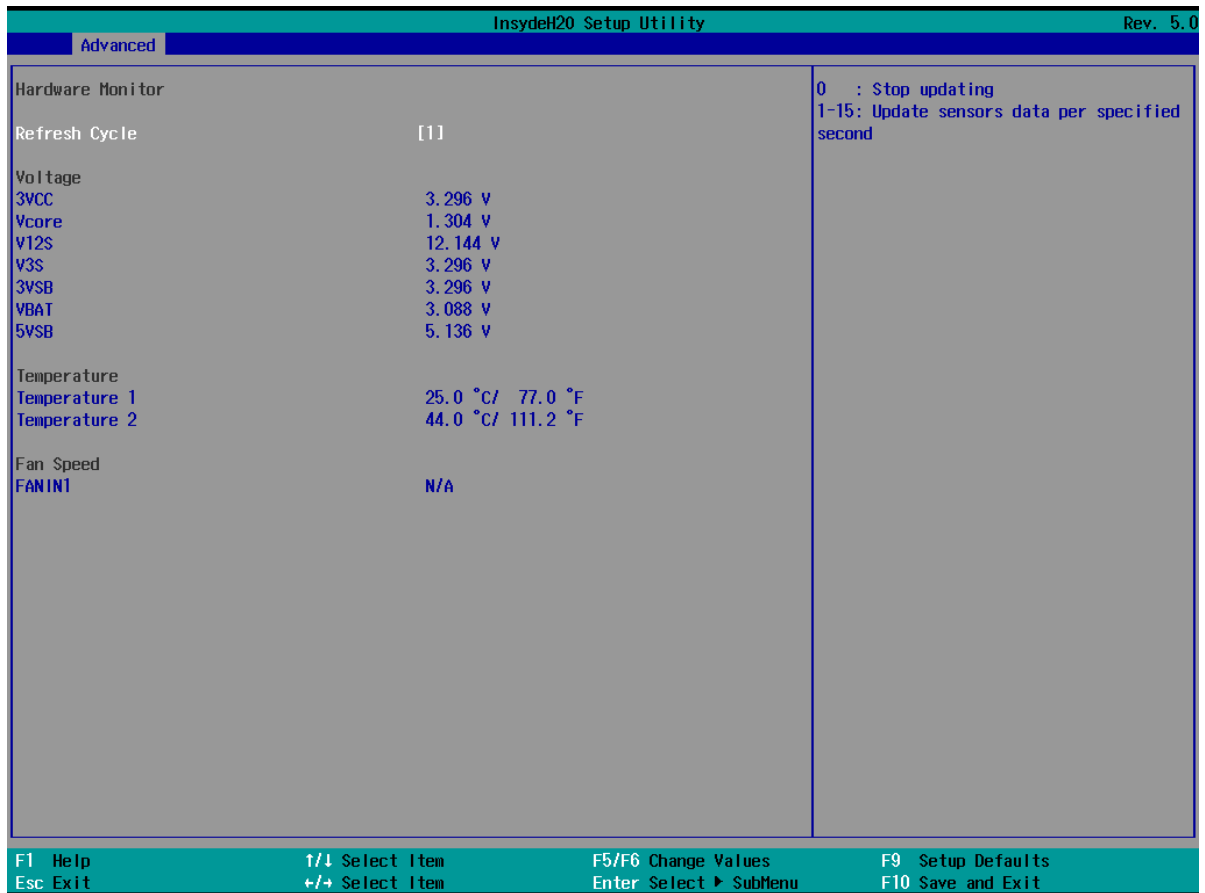

BIOS Setting	Description	Setting Option	Effect
FAN1 Mode	FAN1 Mode configuration	Manual Linear Stage	Select FAN1 Mode configuration

4.2.2.6.2 GPIO Configuration

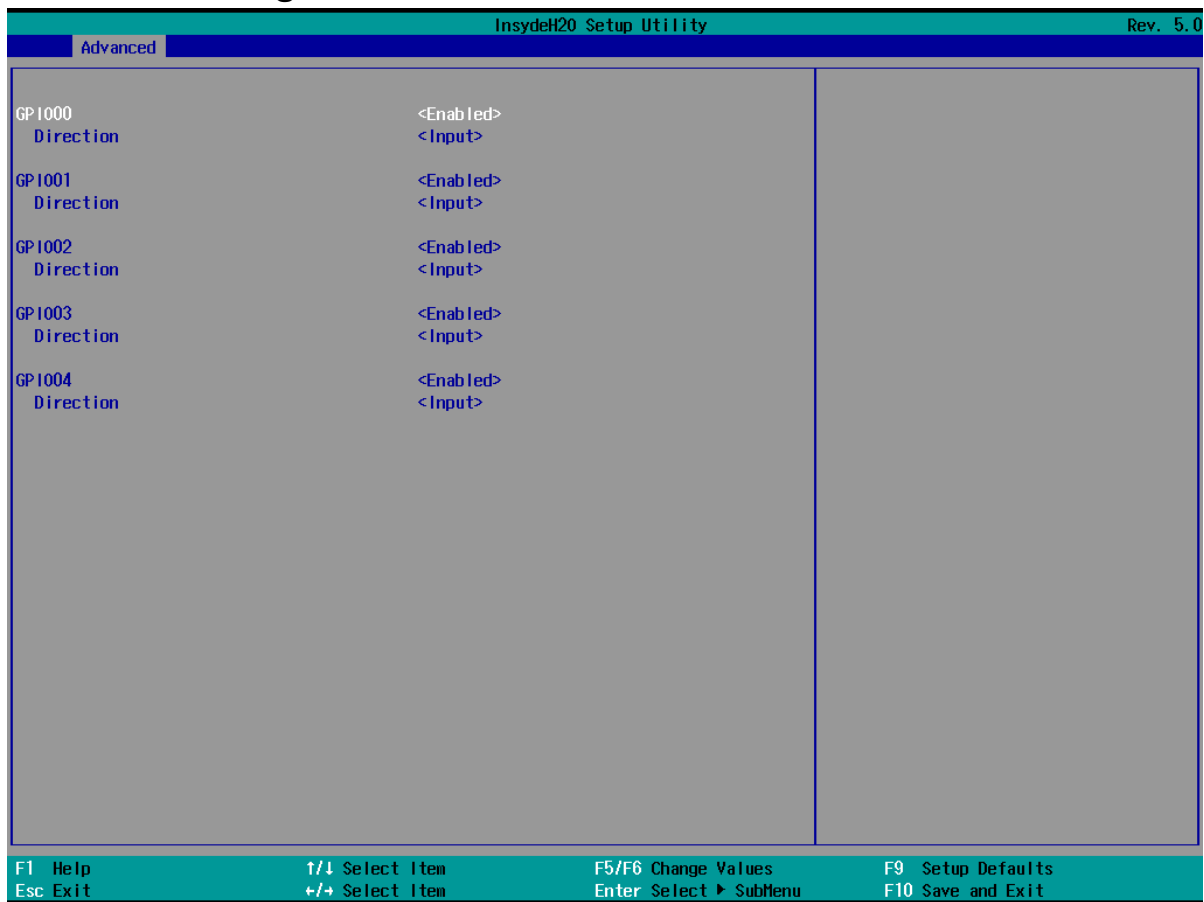

BIOS Setting	Description	Setting Option	Effect
Internal Resistance	Internal Resistance configuration	Push Pull Open Drain	User can pull internal resistance push-pull / open-drain
Input/ Output Mode	GPIO pin configuration	Input Output	Set GPIO pin is input or output

4.2.3 Security

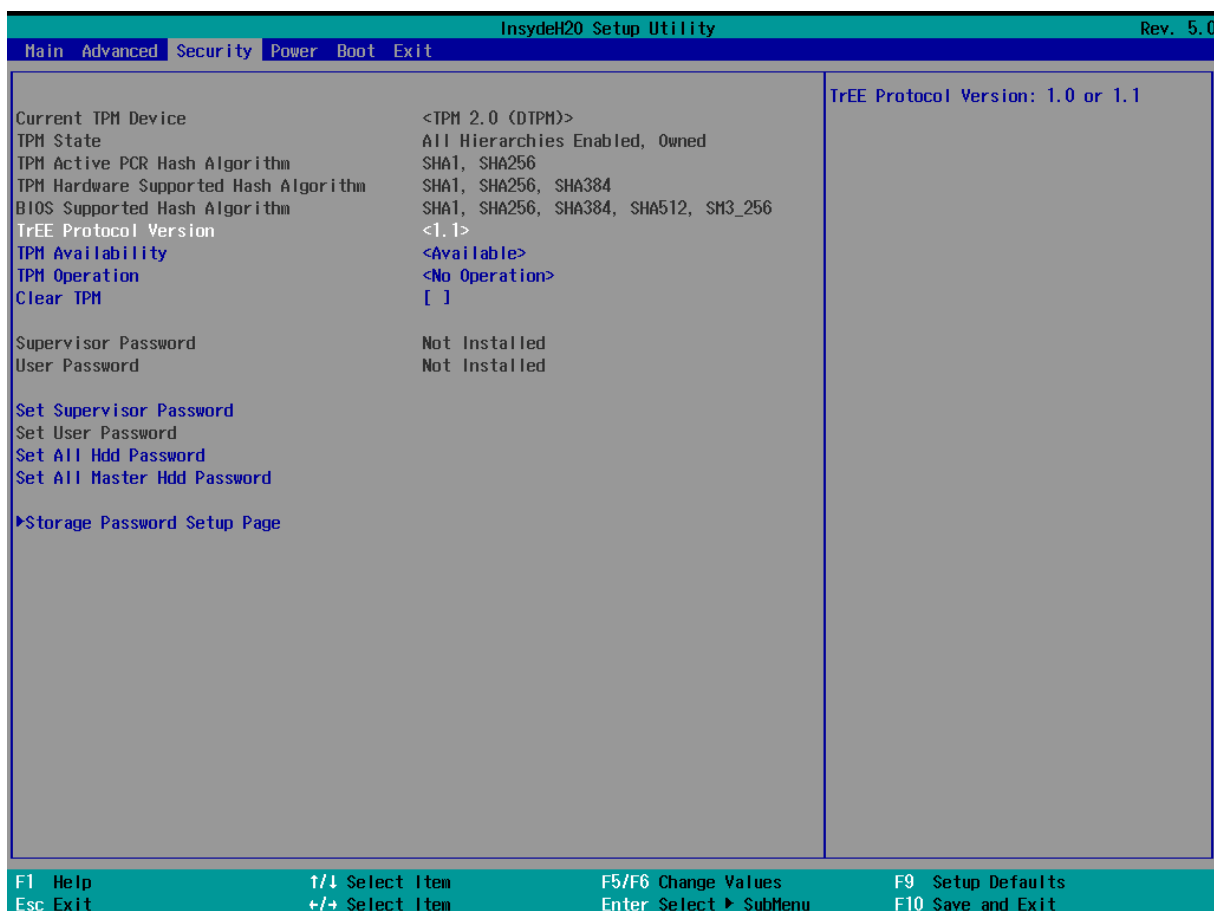

BIOS Setting	Description	Setting Option	Effect
TrEE Protocol Version	Choose TrEE Protocol Version	1.0 1.1	TrEE Protocol Version: 1.0 or 1.1
TPM Availability	TPM Availability configuration	Available Hidden	When hidden don't exposes TPM to 0
TPM Operation	TPM Operation configuration	[]	Select one of the supported operations to change TPM2state
Clear TPM	Clear TPM configuration	[]	Select to Clear TPM
Set Supervisor Password	Set Supervisor Password	Enter New password	Install or change the password and the length of password must be greater than one character

4.2.4 Power

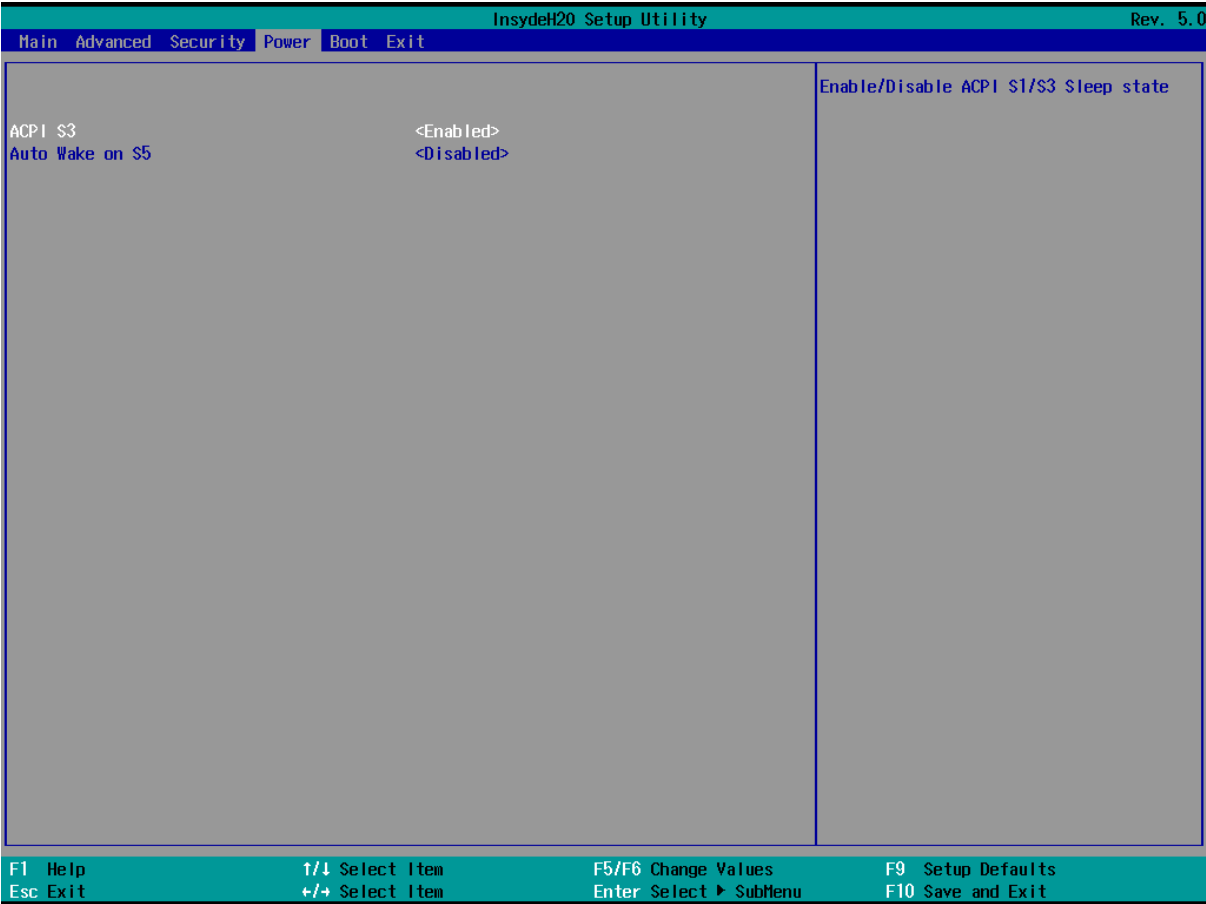

BIOS Setting	Description	Setting Option	Effect
ACPI S3	ACPI S3 configuration	Disabled Enabled	Enable/ Disable ACPI S1/S3 Sleep state
Auto Wake on S5	Auto Wake on S5 configuration	Disabled By Every Day By Every Month	Auto Wake on S5, by Day or Month or fixed time of every day

4.2.5 Boot

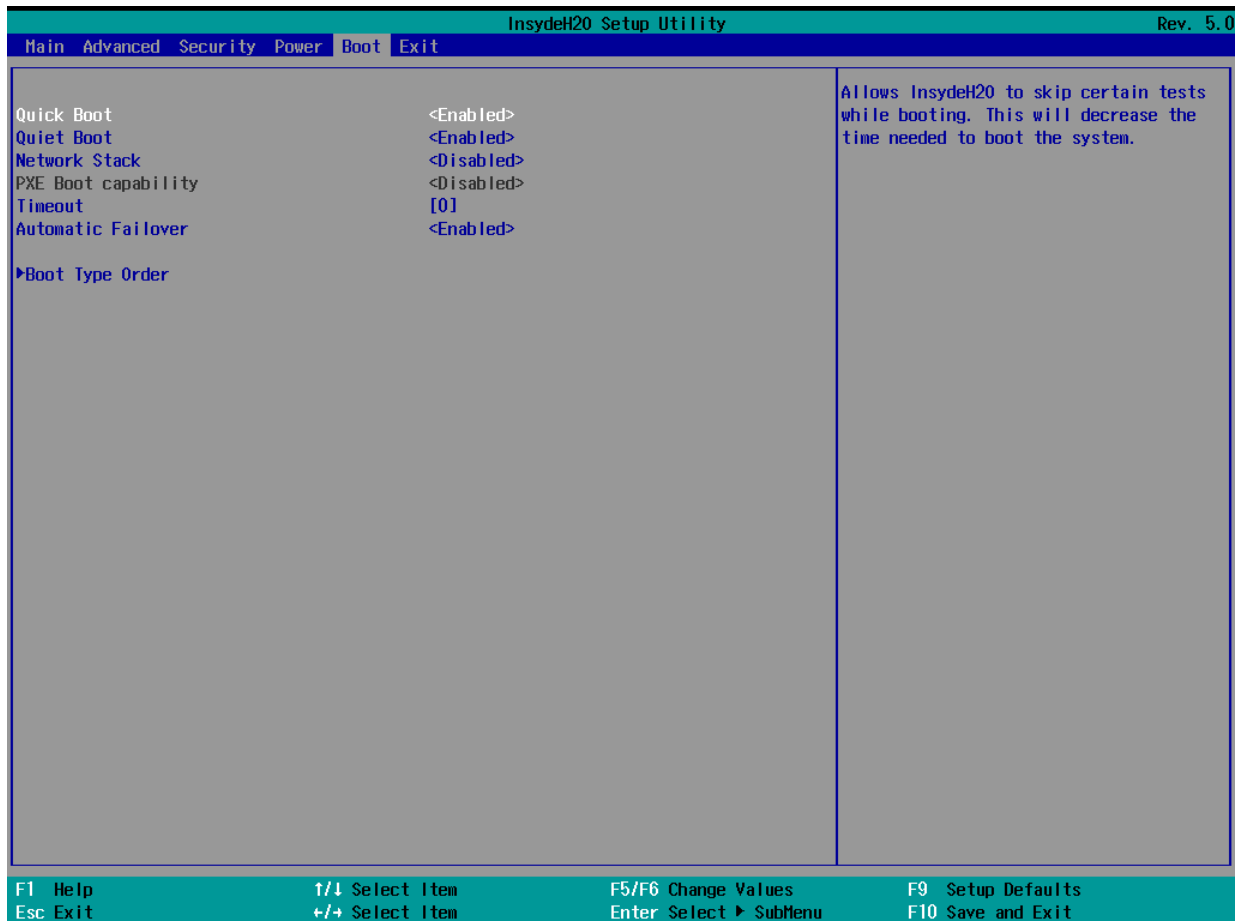

BIOS Setting	Description	Setting	Effect
Boot Type	Boot Type configuration	UEFI Boot Type	Select boot type to Dual type, Legacy type or UEFI type
Quick Boot	Quick Boot configuration	Enabled Disabled	Allows InsydeH20 to skip certain tests while booting. This will decrease the time needed to boot the system
Quiet Boot	Quiet Boot configuration	Enabled Disabled	Disable or enable booting in text Mode.
Network Stack	Network Stack configuration	Disabled Enabled	Network Stack Support: Windows 8 Bitlocker Unlock UEFI IPv4/ IPv6 PXE Legacy PXE OPROM
Timeout	Timeout	[Value]	Timeout settings
Automatic Failover		Enable	If boot to default device fail, it will directly try to boot next device
		Disable	If boot to default device fail, it will pop warning message then go to firmware UI
Boot Type Order	Boot Type Order	Enter	Opens sub-menu

4.2.5.1 PXE Boot

1. Press del to boot BIOS setup utility then change "Network Stack" setting to enable at Boot page.

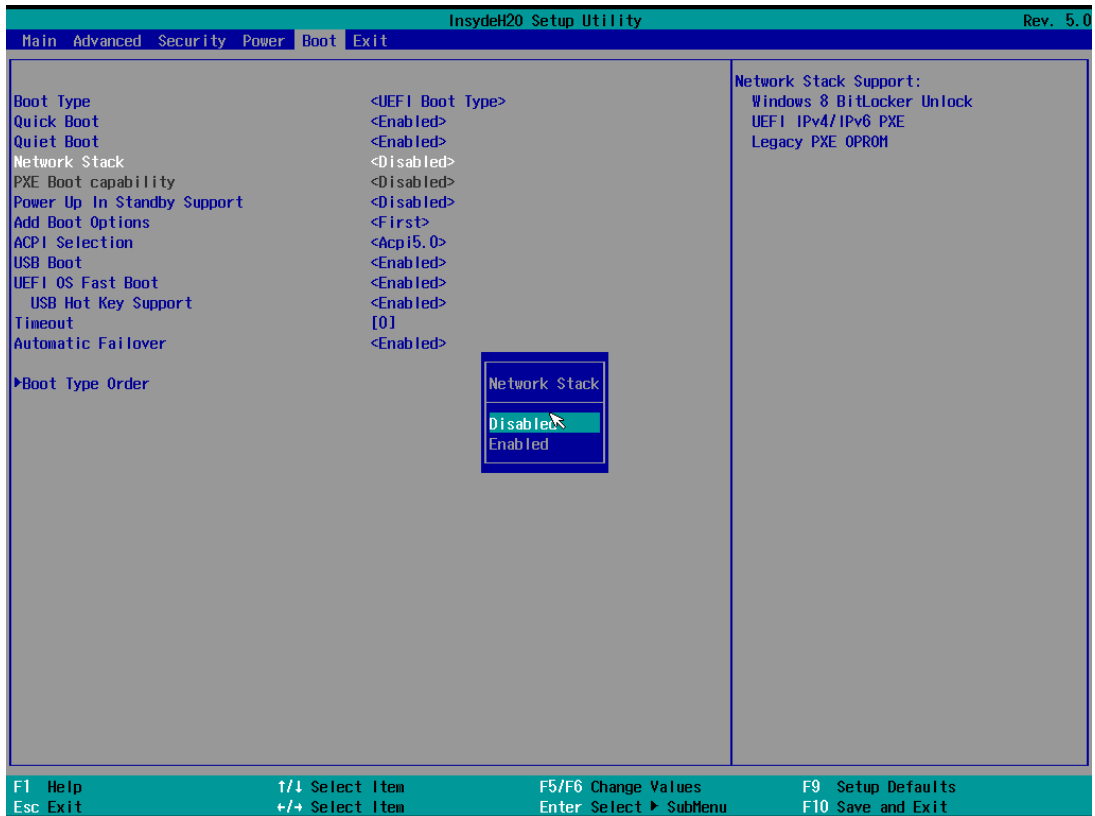

2. Change Boot capability to UEFI:Ipv4/IPv6 that support both protocol.

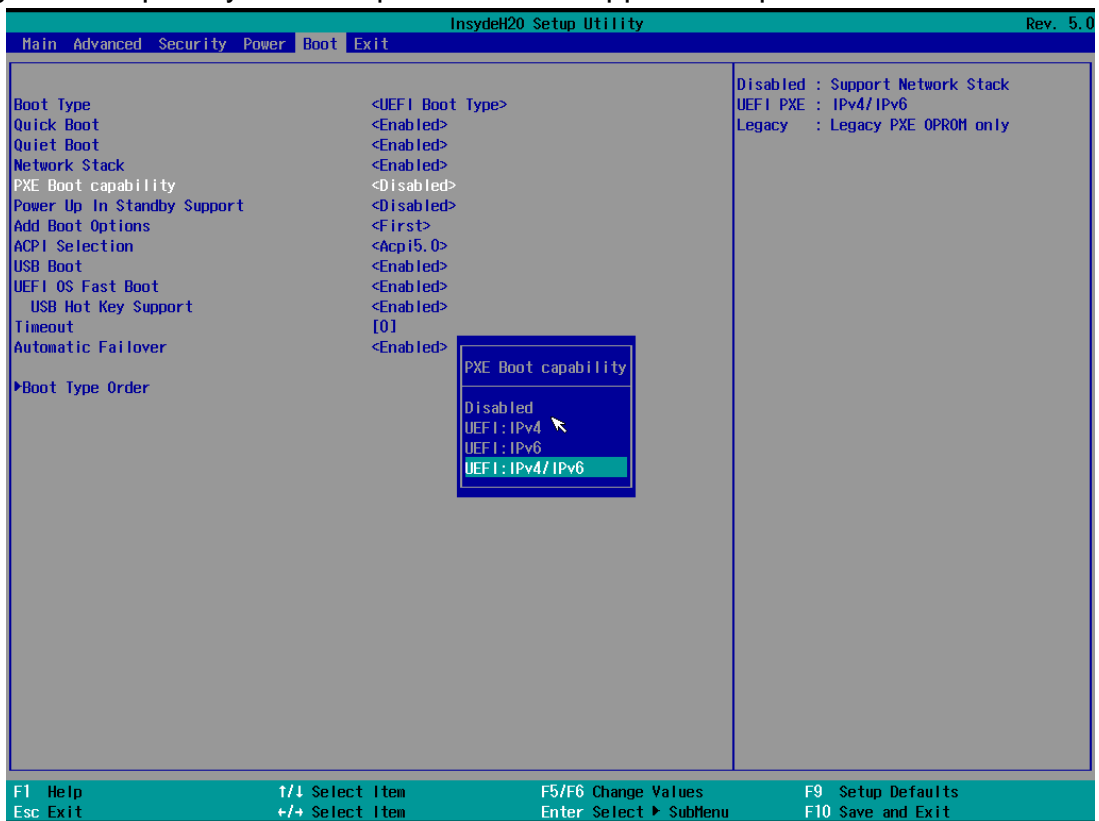

3. Type F10 to save setting and exit then reboot it will auto connects media server. If you see picture as bellow please checks your server.

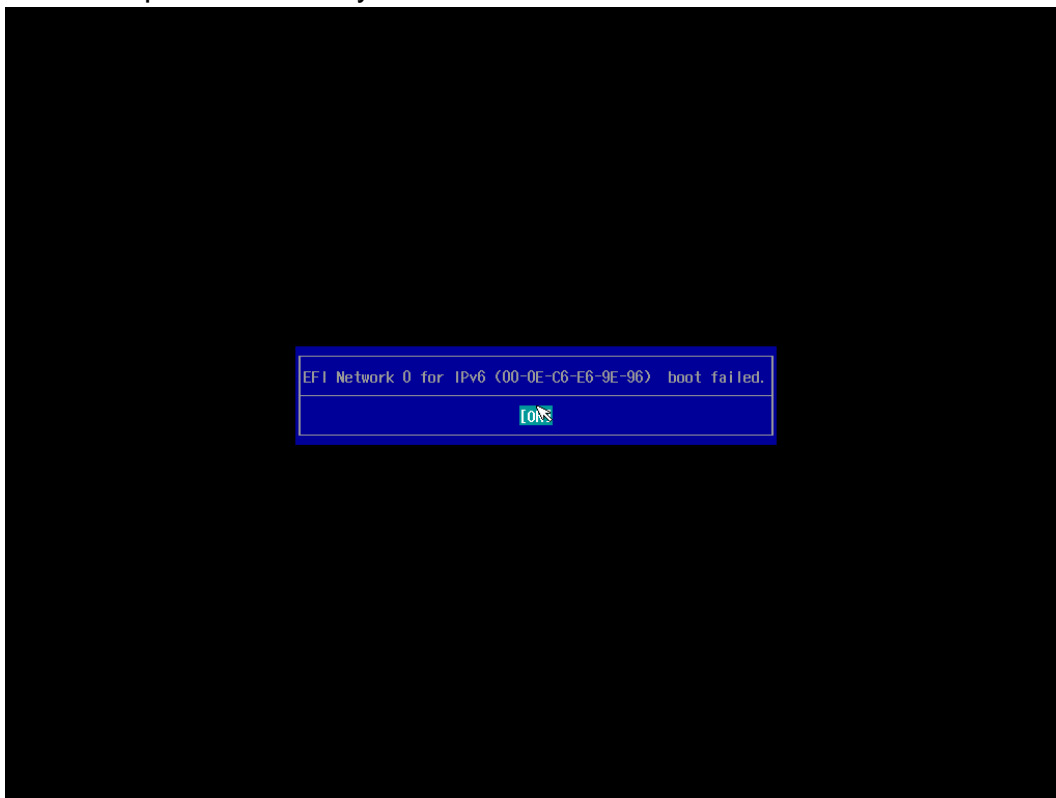

4. You also can press "esc" go into boot manager to choose which one LAN you want to do PXE if you have more than one LAN.

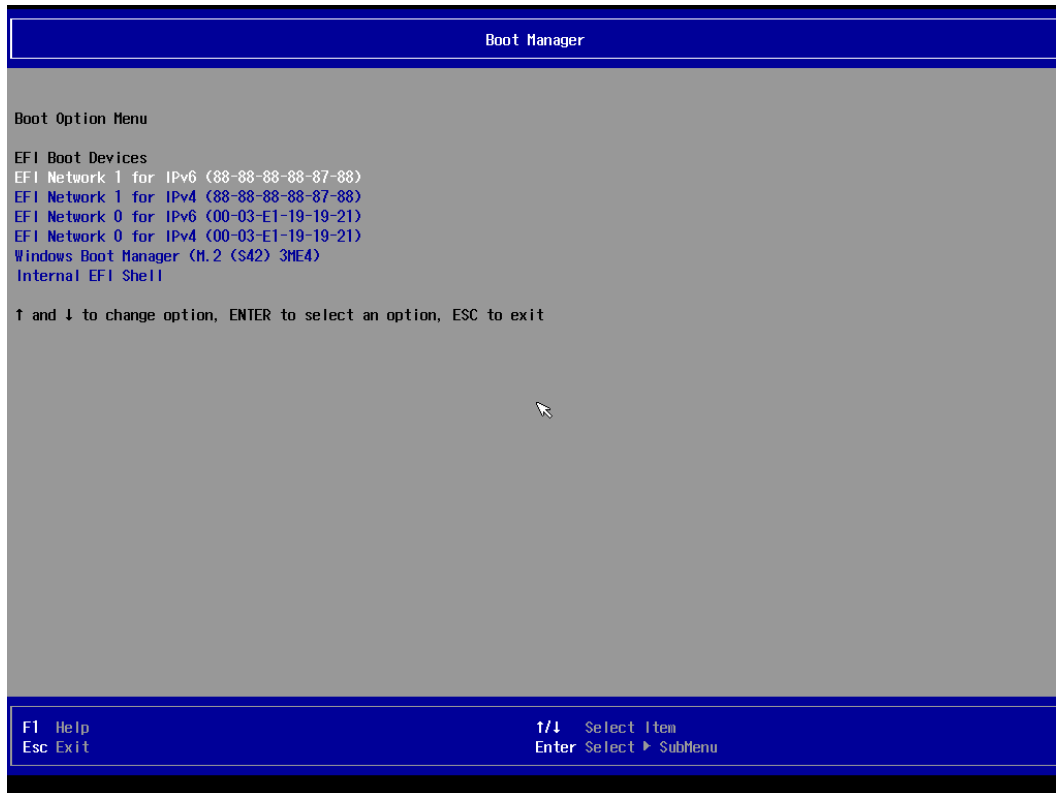

4.2.6 Exit

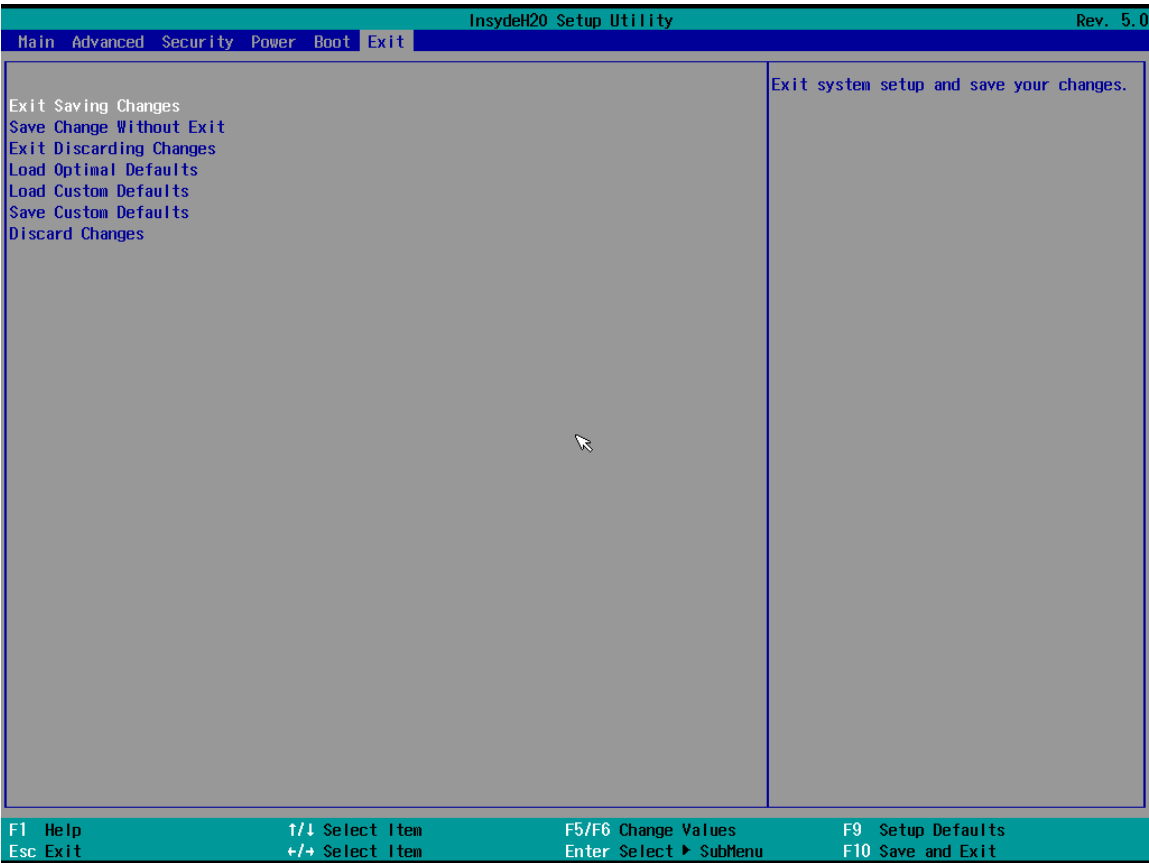

4.3 Using Recovery Wizard to Restore Computer



Note:

Before starting the recovery process, make sure to backup all user data. The data will be lost after the recovery process.



Important:

Before starting the recovery process, remove any expansion card.

To enable quick one-key recovery procedure:

1. Connect the computer to the power source. Make sure the computer stays plugged in to power source during the recovery process.
2. Turn on the computer, and when the boot screen shows up, press **F6** to initiate the Recovery Wizard.
3. The following screen shows the Recovery Wizard. Click **Recovery** button to continue.



4. A warning message about data loss will show up. Make sure the data is backed up before recovery, and click **Yes** to continue.





5. Wait the recovery process to complete. During the recovery process, a command prompt will show up to indicate the percent of recovery process complete. After complete the recovery process, the system will be turned off automatically. Please restart your system manually to complete the OS initialize process.

4.4 How to Enable Watchdog

To enable Watchdog, you need to download Winmate Watchdog utility. Find more information on Watchdog in “Watchdog Guide” that you can download from Winmate Download Center or File Share.

To enable watchdog in Watchdog AP follow the instructions below:

1. On the right bottom side of the desktop screen, click  **triangle button** to show hidden icons.
2. Click  icon to open Watchdog utility.

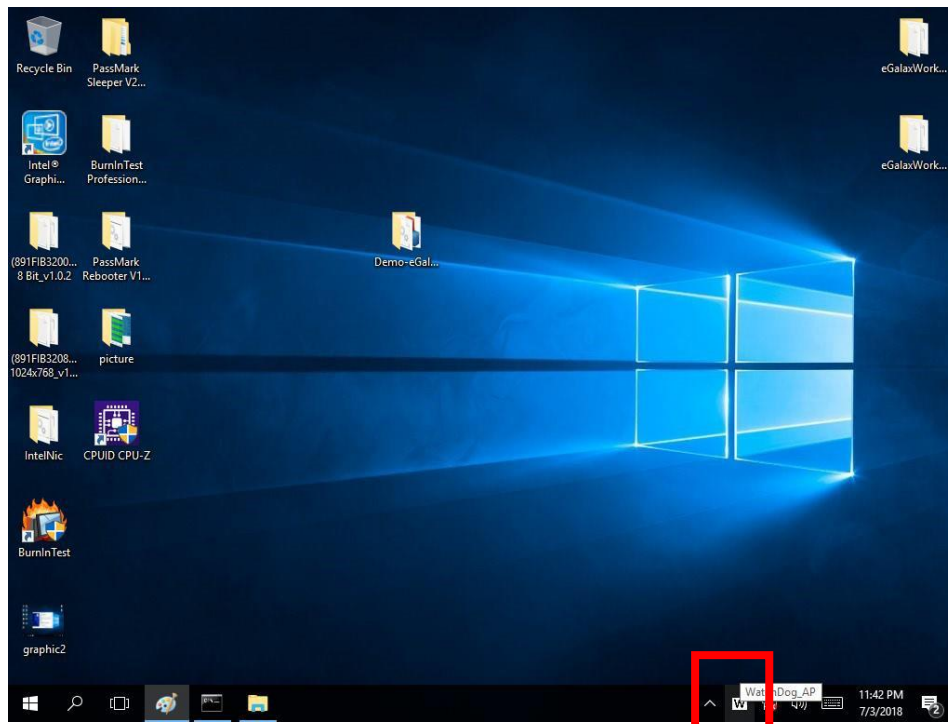

3. In Watchdog utility window set countdown time and periodically feed time, or disable watchdog.

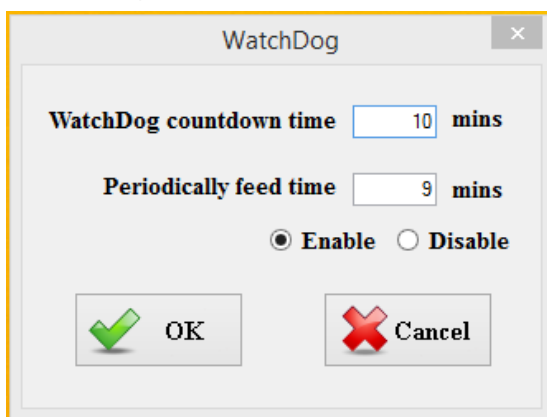

Example:

Every 10 min watchdog will monitor the system, in case any error occurs the system will restart automatically when the countdown time reaches 0.

Every 9 min watchdog timer will be reset to 10 min.

Setting	Description
Watchdog Countdown Time	The system automaticity restarts when this countdown time reaches zero. <i>Default: 10 min</i>
Periodically Feed Time	To set a cycle time to automatically reset watchdog timer. <i>Default: 9 min</i>
Enable / Disable	Enable or disable watchdog. <i>Default: Enable</i>

Chapter 5: Technical Support

This chapter contains directory to technical support.

5.1 Drivers

5.2 Software Development Kit (SDK)

This chapter includes the directory for technical support. Free technical support is available from our engineers every business day. We are always ready to give advice on application requirements or specific information on the installation and operation of any of our products. If any problem occurs immediately contact us.

5.1 Drivers

The list of drivers available for IT32 Motherboard:

Item	Driver
1	Chipset Driver
2	Graphics Driver
3	ME Driver
4	Audio Driver
5	LAN Driver
6	DTT Driver
7	GNA Driver
8	Serial IO Driver
9	Resistive Touch Driver
10	Package Power Control Driver
11	Winset_Watch Dog Driver
12	WMDIO APP

To find the Drivers, please refer to Winmate website or contact us.

5.2 Software Development Kit (SDK)

The list of SDK available for IT32 Motherboard

Item	File Type	Description
1	SDK	Watchdog SDK
2	SDK	Digital IO SDK

To find the SDK, please refer to Winmate website or contact us.

Winmate Inc.
9F, No.111-6, Shing-De Rd., San-Chung District,
New Taipei City 24158, Taiwan, R.O.C
www.winmate.com

Copyright © 2024 Winmate Inc. All rights reserved.

