

M.2 (S42)

3TEB series

Customer: _____
Customer
Part Number: _____
Innodisk
Part Number: _____
Innodisk
Model Name: _____
Date: _____

Innodisk Approver	Customer Approver

Features:

- SATA III
- Kioxia 3D TLC NAND
- M.2 2242-D2-B+M
- Standard & Wide-temperature
- iPower Guard
- iData Guard
- Dynamic Thermal Management

Performance:

- Sequential Read up to 560 MB/s
- Sequential Write up to 480 MB/s

Power Requirements:

Input Voltage:	3.3V±5%
Max Operating Wattage:	1.2W
Idle Wattage:	0.3W

Reliability:

Capacity	TBW	DWPD
64GB	65	1.09
128GB	150	1.26
256GB	260	1.09
512GB	582	1.22
1TB	900	0.94

Data Retention	1 Year
Warranty	3 Years

1-year data retention is at NAND life end.

For warranty details, please refer to:

https://www.innodisk.com/en/support_and_service/warranty

Table of contents

1. PRODUCT OVERVIEW	8
1.1 INTRODUCTION OF INNODISK M.2 (S42) 3TEB	8
1.2 PRODUCT VIEW AND MODELS	8
1.3 SATA INTERFACE	8
2. PRODUCT SPECIFICATIONS	9
2.1 CAPACITY AND DEVICE PARAMETERS	9
2.2 PERFORMANCE	9
2.3 ELECTRICAL SPECIFICATIONS	10
2.3.1 Power Requirement	<i>10</i>
2.3.2 Power Consumption	<i>10</i>
2.4 ENVIRONMENTAL SPECIFICATIONS	10
2.4.1 Temperature Ranges	<i>10</i>
2.4.2 Humidity	<i>10</i>
2.4.3 Shock and Vibration	<i>10</i>
2.4.4 Mean Time between Failures (MTBF)	<i>10</i>
2.5 CE AND FCC COMPATIBILITY	11
2.6 RoHS COMPLIANCE	11
2.7 RELIABILITY	11
2.8 TRANSFER MODE	12
2.9 PIN ASSIGNMENT	12
2.10 MECHANICAL DIMENSIONS	14
2.11 ASSEMBLY WEIGHT	14
2.12 SEEK TIME	14
2.13 HOT PLUG	14
2.14 NAND FLASH MEMORY	14
3. THEORY OF OPERATION	15
3.1 OVERVIEW	15
3.2 SATA III CONTROLLER	15
3.3 ERROR DETECTION AND CORRECTION	15
3.4 WEAR-LEVELING	16
3.5 BAD BLOCKS MANAGEMENT	16
3.6 iDATA GUARD	16
3.7 GARBAGE COLLECTION	16
3.8 TRIM	16
3.9 iPOWER GUARD	16
3.10 THERMAL THROTTLING	17
4. INSTALLATION REQUIREMENTS	18

- 4.1 M.2 (S42) 3TEB PIN DIRECTIONS..... 18**
- 4.2 ELECTRICAL CONNECTIONS FOR M.2 (S42) 3TEB 18**
- 4.3 DEVICE DRIVE 18**
- 5. SMART FEATURE SET19**
 - 5.1 SMART ATTRIBUTES..... 19**
- 6. PART NUMBER RULE21**

REVISION HISTORY

Revision	Description	Date
V1.0	Official Release	Mar., 2024
V1.1	Add 112 Layers 3D TLC wide temperature & 64GB, 2TB. Revise SMART Attributes Update TBW	Aug., 2024
V1.2	Update Data Retention content	Jan., 2024

List of Tables

TABLE 1: DEVICE PARAMETERS	9
TABLE 2: PERFORMANCE – 112 LAYERS 3D TLC*	9
TABLE 3: INNODISK M.2 (S42) 3TEB POWER REQUIREMENT	10
TABLE 4: TYPICAL POWER CONSUMPTION	10
TABLE 5: TEMPERATURE RANGE FOR M.2 (S42) 3TEB	10
TABLE 6: SHOCK/VIBRATION TESTING FOR M.2 (S42) 3TEB	10
TABLE 7: M.2 (S42) 3TEB MTBF	11
TABLE 8: M.2 (S42) 3TEB TBW	11
TABLE 9: INNODISK M.2 (S42) 3TEB PIN ASSIGNMENT	12
TABLE 10: SMART COMMAND	19
TABLE 11: SMART ATTRIBUTE	19

List of Figures

FIGURE 1: INNODISK M.2 (S42) 3TEB (TYPE 2242)	8
FIGURE 2: INNODISK M.2 (S42) 3TEB DIAGRAM	14
FIGURE 3: INNODISK M.2 (S42) 3TEB BLOCK DIAGRAM	15
FIGURE 4: SIGNAL SEGMENT AND POWER SEGMENT	18

1. Product Overview

1.1 Introduction of Innodisk M.2 (S42) 3TEB

Innodisk M.2 (S42) 3TEB provides high capacity flash memory Solid State Drive (SSD) that electrically complies with Serial ATA (SATA) standard. It supports SATA III standard (6.0GHz) with high performance, achieves excellent performance up to 2CH standard by cost effective controller with 2CH.

With Innodisk L³ FW architecture, combining our signature 4K mapping algorithm L² FW architecture with powerful LDPC technology, 3TEB series has outstanding high IOPS, better data integrity and extended lifespan through reducing the bad block number happening.

For real industrial application, 3TEB series has built-in thermal sensor to monitor the environment temperature. iData Guard, the power loss management mechanism developed by Innodisk, ensures data integrity while power sudden loss happened.

CAUTION *TRIM must be enabled.*

TRIM enables SSD's controller to skip invalid data instead of moving. It can free up significant amount of resources, extends the lifespan of SSD by reducing erase, and write cycles on the SSD. Innodisk's handling of garbage collection along with TRIM command improves write performance on SSDs.

1.2 Product View and Models

Innodisk M.2 (S42) 3TEB is available in follow capacities within 3D TLC flash ICs.

M.2 (S42) 3TEB 64GB M.2 (S42) 3TEB 128GB

M.2 (S42) 3TEB 256GB M.2 (S42) 3TEB 512GB

M.2 (S42) 3TEB 1TB

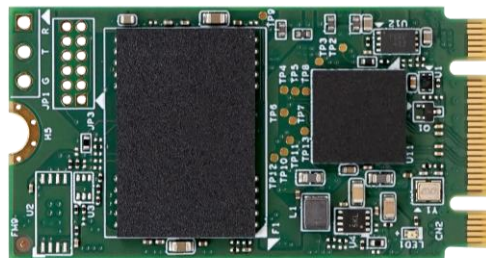

Figure 1: Innodisk M.2 (S42) 3TEB (type 2242)

1.3 SATA Interface

Innodisk M.2 (S42) 3TEB supports SATA III interface, and compliant with SATA I and SATA II. SATA III interface can work with Serial Attached SCSI (SAS) host system, which is used in server computer. Innodisk M.2 (S42) 3TEB is compliant with Serial ATA Gen 1, Gen 2 and Gen 3 specification (Gen 3 supports 1.5Gbps /3.0Gbps/6.0Gbps data rate).

2. Product Specifications

2.1 Capacity and Device Parameters

M.2 (S42) 3TEB device parameters are shown in Table 1.

Table 1: Device parameters

Capacity	Cylinders	Heads	Sectors	LBA	User Capacity(MB)
64GB	16383	16	63	117231408	57242
128GB	16383	16	63	234441648	114473
256GB	16383	16	63	468862128	228936
512GB	16383	16	63	937703088	457862
1TB	16383	16	63	1875385008	915715

Note: User capacity is different because of the Die RAID function.

2.2 Performance

Burst Transfer Rate: 6.0Gbps

Table 2: Performance – 112 Layers 3D TLC*

Capacity	Unit	64GB	128GB	256GB	512GB	1TB
Sequential** Read (Q32T1.)	MB/s	440	550	550	560	550
Sequential** Write (Q32T1.)		280	450	480	470	480
Sustained Sequential Read (Avg.)***		230	470	500	500	500
Sustained Sequential Write (Avg.)***		100	180	200	220	230
4KB Random** Read (QD32)	IOPS	23,000	44,000	77,000	67,000	71,000
4KB Random** Write (QD32)		61,000	60,000	77,000	62,000	77,000

Note: * Performance results are tested in Room Temperature with Out-of-Box devices and may vary depending on overall system setup. In addition, 3TEB series adopt hybrid mode which enables SLC Cache followed by TLC direct write to strike balance between burst performance and steady overall stability.

Note: ** Performance results are based on CrystalDiskMark 8.0.1 with file size 1000MB.

Note: *** Performance results are based on AIDA 64 v5.98 with block size 1MB of Linear Write Test Item

2.3 Electrical Specifications

2.3.1 Power Requirement

Table 3: Innodisk M.2 (S42) 3TEB Power Requirement

Item	Symbol	Rating	Unit
Input voltage	V _{IN}	+3.3 DC +- 5%	V

2.3.2 Power Consumption

Table 4: Typical Power Consumption

Mode	Power consumption (W)
Read	1.1
Write	1.2
Idle	0.3
Power-on peak	2.5

Target: M.2 (S42) 3TEB 1TB

2.4 Environmental Specifications

2.4.1 Temperature Ranges

Table 5: Temperature range for M.2 (S42) 3TEB

Temperature	Range
Operating	Standard Grade: 0°C to +70°C
	Industrial Grade: -40°C to +85°C
Storage	-40°C to +85°C

2.4.2 Humidity

Relative Humidity: 10-95%, non-condensing

2.4.3 Shock and Vibration

Table 6: Shock/Vibration Testing for M.2 (S42) 3TEB

Reliability	Test Conditions	Reference Standards
Vibration	7 Hz to 2K Hz, 20G, 3 axes	IEC 60068-2-6
Mechanical Shock	Duration: 0.5ms, 1500 G, 3 axes	IEC 60068-2-27

2.4.4 Mean Time between Failures (MTBF)

The following table summarizes the MTBF prediction results for various M.2 (S42) 3TEB configurations. The analysis was performed using a RAM Commander™ failure rate prediction.

- **Failure Rate:** The total number of failures within an item population, divided by the total number of life units expended by that population, during a particular measurement interval under stated condition.
- **Mean Time between Failures (MTBF):** A basic measure of reliability for repairable items: The mean number of life units during which all parts of the item perform within their specified limits, during a particular measurement interval under stated conditions.

Table 7: M.2 (S42) 3TEB MTBF

Product	Condition	MTBF (Hours)
Innodisk M.2 (S42) 3TEB	Telcordia SR-332 GB, 25°C	>3,000,000

2.5 CE and FCC Compatibility

M.2 (S42) 3TEB conforms to CE and FCC requirements.

Reliability	Reference standards
Electrostatic Discharge (ESD)	EC 61000-4-2 ESD

2.6 RoHS Compliance

M.2 (S42) 3TEB is fully compliant with RoHS directive.

2.7 Reliability

Table 8: M.2 (S42) 3TEB TBW

Parameter	Value	
Flash endurance	3,000 P/E cycles	
Error Correct Code	Support	
Data Retention	Under 40 C: 1 Year at NAND Life End	
TBW* (Total Bytes Written) Unit: TB		
Capacity	Sequential workload	Client workload
64GB	170	65
128GB	341	150
256GB	682	260
512GB	1364	582
1TB	2727	900
* Note:		
1. Sequential: Mainly sequential write are estimated by PassMark Burnin Test v8.1 pro.		
2. Client: Follow JESD218 Test method and JESD219A Workload, tested by ULINK.		
3. Based on out-of-box performance.		

2.8 Transfer Mode

M.2 (S42) 3TEB support following transfer mode:

Serial ATA III 6.0Gbps

Serial ATA II 3.0Gbps

Serial ATA I 1.5Gbps

2.9 Pin Assignment

Innodisk M.2 (S42) 3TEB uses a standard SATA pin-out. See following table for M.2 (S42) 3TEB pin assignment.

Table 9: Innodisk M.2 (S42) 3TEB Pin Assignment

Signal Name	Pin #	Pin #	Signal Name
		75	GND
3.3V	74	73	GND
3.3V	72	71	GND
3.3V	70	69	GND
NC	68	67	NC
Notch	66	65	Notch
Notch	64	63	Notch
Notch	62	61	Notch
Notch	60	59	Notch
NC	58		
NC	56	57	GND
NC	54	55	NC
NC	52	53	NC
NC	50	51	GND
NC	48	49	RX+
NC	46	47	RX-
NC	44	45	GND
NC	42	43	TX-
NC	40	41	TX+
DEVSLP	38	39	GND
NC	36	37	NC
NC	34	35	NC
NC	32	33	GND
NC	30	31	NC
NC	28	29	NC
NC	26	27	GND
NC	24	25	NC

NC	22	23	NC
NC	20	21	GND
Notch	18	19	Notch
Notch	16	17	Notch
Notch	14	15	Notch
Notch	12	13	Notch
DAS/DSS	10	11	NC
NC	8	9	NC
NC	6	7	NC
3.3V	4	5	NC
3.3V	2	3	GND
		1	GND

2.10 Mechanical Dimensions

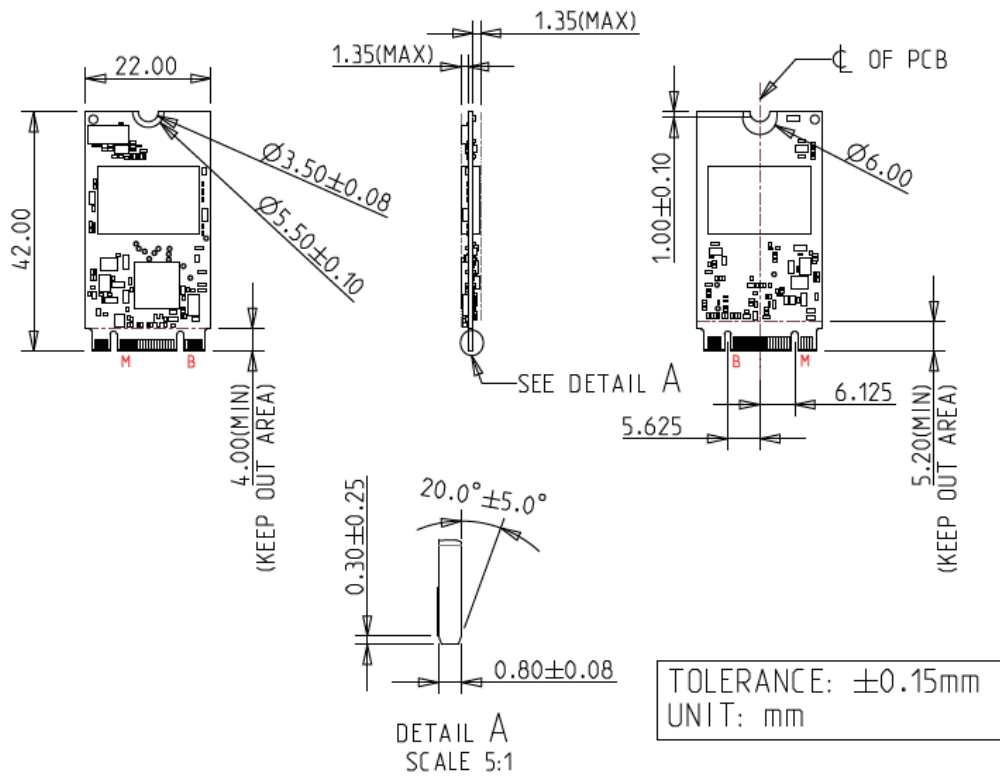

Figure 2: Innodisk M.2 (S42) 3TEB diagram

2.11 Assembly Weight

An Innodisk M.2 (S42) 3TEB within flash ICs, 1TB's weight is 8 grams approximately.

2.12 Seek Time

Innodisk M.2 (S42) 3TEB is not a magnetic rotating design. There is no seek or rotational latency required.

2.13 Hot Plug

The SSD support hot plug function and can be removed or plugged-in during operation. User has to avoid hot plugging the SSD which is configured as boot device and installed operation system.

Surprise hot plug : The insertion of a SATA device into a backplane (combine signal and power) that has power present. The device powers up and initiates an OOB sequence.

Surprise hot removal: The removal of a SATA device from a powered backplane, without first being placed in a quiescent state.

2.14 NAND Flash Memory

Innodisk M.2 (S42) 3TEB uses 3D TLC NAND flash memory, which is non-volatility, high reliability and high speed memory storage.

3. Theory of Operation

3.1 Overview

Figure 3 shows the operation of Innodisk M.2 (S42) 3TEB from the system level, including the major hardware blocks.

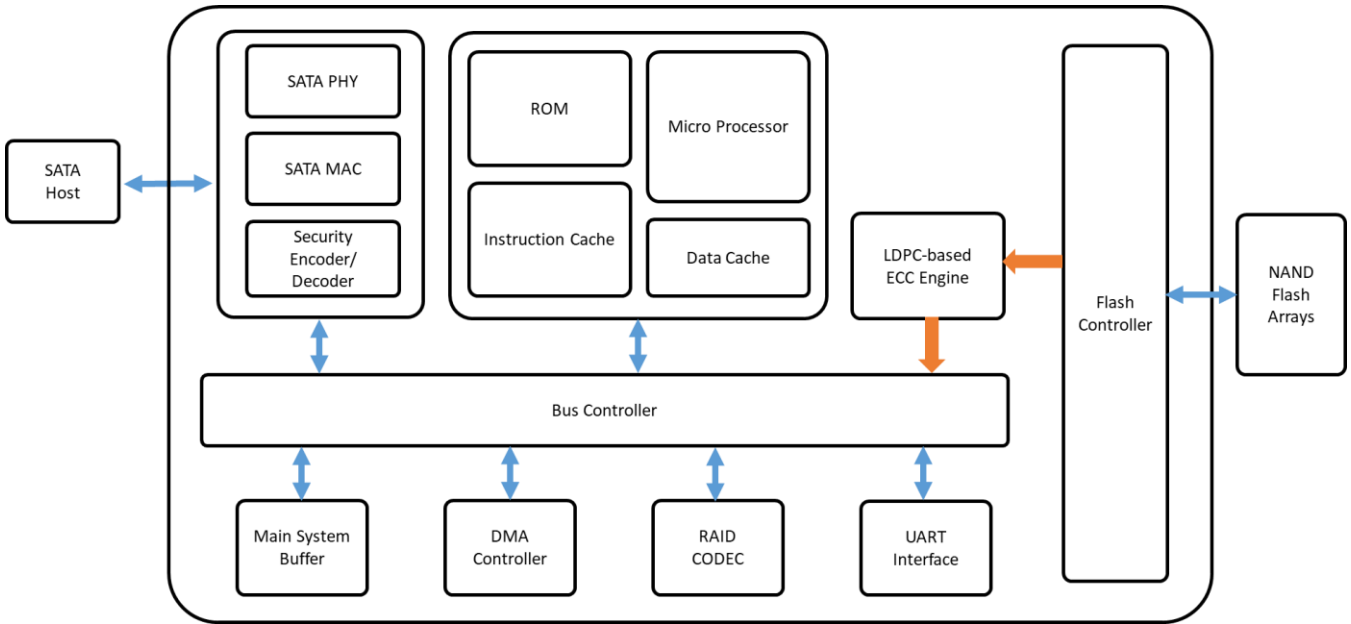

Figure 3: Innodisk M.2 (S42) 3TEB Block Diagram

Innodisk M.2 (S42) 3TEB integrates a SATA III controller and NAND flash memories. Communication with the host occurs through the host interface, using the standard ATA protocol. Communication with the flash device(s) occurs through the flash interface.

3.2 SATA III Controller

Innodisk M.2 (S42) 3TEB is designed with SATA III 6.0Gbps (Gen. 3) Controller, a SATA III 6.0Gbps (Gen. 3) controller. The Serial ATA physical, link and transport layers are compliant with Serial ATA Gen 1, Gen 2 and Gen 3 specification (Gen 3 supports 1.5Gbps/3.0Gbps/6.0Gbps data rate). The controller has 2 channels for flash interface.

3.3 Error Detection and Correction

Innodisk M.2 (S42) 3TEB is designed with hardware LDPC ECC engine with hard-decision and soft-decision decoding. Low-density parity-check (LDPC) codes have excellent error correcting performance close to the Shannon limit when decoded with the belief-propagation (BP) algorithm using soft-decision information.

3.4 Wear-Leveling

Flash memory can be erased within a limited number of times. This number is called the **erase cycle limit** or **write endurance limit** and is defined by the flash array vendor. The erase cycle limit applies to each individual erase block in the flash device.

Innodisk M.2 (S42) 3TEB uses a static wear-leveling algorithm to ensure that consecutive writes of a specific sector are not written physically to the same page/block in the flash. This spreads flash media usage evenly across all pages, thereby extending flash lifetime.

3.5 Bad Blocks Management

Bad Blocks are blocks that contain one or more invalid bits whose reliability are not guaranteed. The Bad Blocks may be presented while the SSD is shipped, or may develop during the life time of the SSD. When the Bad Blocks is detected, it will be flagged, and not be used anymore. The SSD implement Bad Blocks management, Bad Blocks replacement, Error Correct Code to avoid data error occurred. The functions will be enabled automatically to transfer data from Bad Blocks to spare blocks, and correct error bit.

3.6 iData Guard

iData Guard is a comprehensive data protection mechanism that functions before and after a sudden power outage to SSD. Low-power detection terminates data writing before an abnormal power-off, while table-remapping after power-on deletes corrupt data and maintains data integrity. iData Guard provides effective power cycling management, preventing data stored in flash from degrading with use.

3.7 Garbage Collection

Garbage collection is used to maintain data consistency and perform continual data cleansing on SSDs. It runs as a background process, freeing up valuable controller resources while sorting good data into available blocks, and deleting bad blocks. It also significantly reduces write operations to the drive, thereby increasing the SSD's speed and lifespan.

3.8 Trim

The Trim command is designed to enable the operating system to notify the SSD which pages no longer contain valid data due to erases either by the user or operating system itself. During a delete operation, the OS will mark the sectors as free for new data and send a Trim command to the SSD to mark them as not containing valid data. After that the SSD knows not to preserve the contents of the block when writing a page, resulting in less write amplification with fewer writes to the flash, higher write speed, and increased drive life.

3.9 iPower Guard

iPower Guard technology is a set of preventive measures that protect the SSD in an unstable power supply environment. This comprehensive package comprises safeguards for startup and

shutdown to maintain device performance and ensure data integrity.

3.10 Thermal Throttling

Thermal throttling is a protective mechanism designed to safeguard components from potential damage caused by excessive temperatures. When an SSD approaches a critical temperature threshold, Innodisk firmware activates the thermal throttling mechanism to regulate the SSD's temperature. Thermal throttling is crucial for SSDs since it prevents drive damage, which could otherwise result in data loss. However, it's worth noting that when thermal throttling is activated, read and write tasks may experience a reduction in speed.

4. Installation Requirements

4.1 M.2 (S42) 3TEB Pin Directions

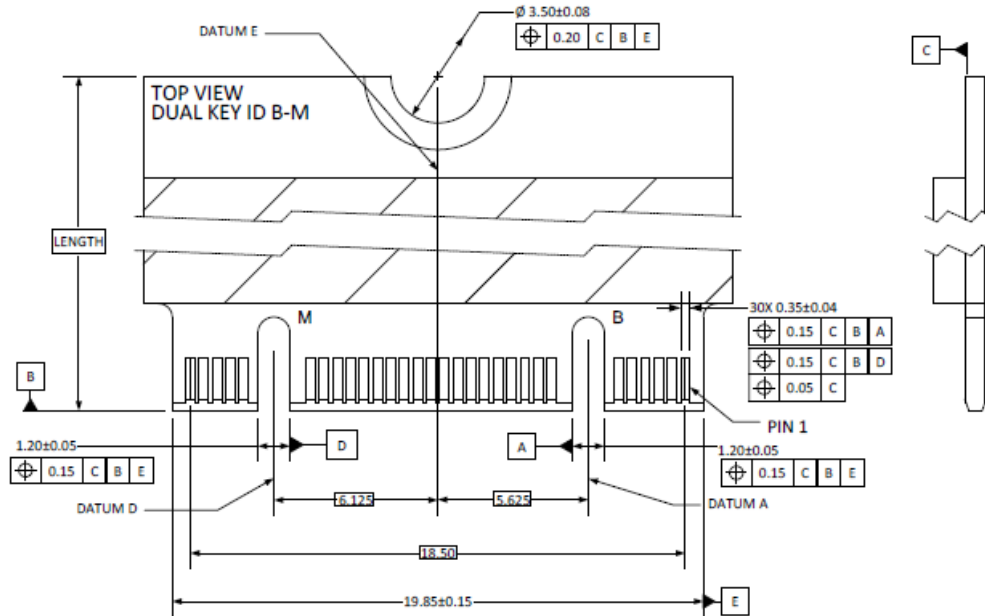

Figure 4: Signal Segment and Power Segment

4.2 Electrical Connections for M.2 (S42) 3TEB

A Serial ATA device may be either directly connected to a host or connected to a host through a cable. For connection via cable, the cable should be no longer than 1meter. The SATA interface has a separate connector for the power supply. Please refer to the pin description for further details.

4.3 Device Drive

No additional device drives are required. The Innodisk M.2 (S42) 3TEB can be configured as a boot device.

5. SMART Feature Set

Innodisk 3TEB series support the SMART command set and defines some vendor-specific data to report SMART attributes of SSD.

Table 10: SMART command

Value	Command	Value	Command
D0h	Read Data	D5h	Read Log
D1h	Read Attribute Threshold	D6h	Return Status
D2h	Enable/Disable Auto save	D8h	Enable SMART Operations
D3h	Save Attribute Values	D9h	Disable SMART Operations
D4h	Execute OFF-LINE Immediate	DAh	Return Status

5.1 SMART Attributes

Innodisk 3TEB series SMART data attributes are listed in following table.

Table 11: SMART attribute

Attribute ID (hex)	Raw Attribute Value							Attribute Name
	MSB						LSB	
01	MSB	00	00	00	00	00	00	Read error rate
05	LSB	MSB	00	00	00	00	00	Reallocated sectors count
09	LSB			MSB	00	00	00	Power on hours
0C	LSB			MSB	00	00	00	Power cycle count
A0	LSB			MSB	00	00	00	Online Uncorrectable sector count
A1	LSB	MSB	00	00	00	00	00	Number of valid spare blocks
A3	LSB	MSB	00	00	00	00	00	Number of initial invalid block
A4	LSB			MSB	00	00	00	Total erase count
A5	LSB			MSB	00	00	00	Max. erase count
A6	LSB			MSB	00	00	00	Min. erase count
A7	LSB			MSB	00	00	00	Average erase count
A9	LSB			MSB	00	00	00	Remain Life (percentage)
B1	LSB			MSB	00	00	00	Wearleveling count
B5	LSB			MSB	00	00	00	Total program fail count
B6	LSB	MSB	00	00	00	00	00	Total erase fail count

C0	LSB	MSB	00	00	00	00	00	Sudden Power Count
C2	MSB	00	00	00	00	00	00	Enclosure Temperature
C3	LSB			MSB	00	00	00	Hardware ECC recovered
C6	LSB	MSB	00	00	00	00	00	Uncorrectable error count Off Line
C7	LSB						MSB	Ultra DMA CRC Error Count
F1	LSB						MSB	Total LBA written(LBA=32MB)
F2	LSB						MSB	Total LBA read(LBA=32MB)

6. Part Number Rule

CODE	1	2	3	4	5	6	7	8	9	10	11	12	13	14	15	16	17	18	19	20	21
	D	E	M	2	4	-	0	1	T	I	C	1	K	C	A	D	F	-	X	X	X
Definition																					
Code 1st (Disk)											Code 14th (Operation Temperature)										
D : Disk											C: Standard Grade (0°C~ +70°C)										
Code 2nd (Feature set)											Code 15th (Internal control)										
E : Embedded series											W: Industrial Grade (-40°C~ +85°C)										
Code 3rd ~5th (Form factor)											Code 16th (Channel of data transfer)										
M24: M.2 Type 2242-D2-B-M											A: BGA PCB version										
Code 7th ~9th (Capacity)											Code 17th (Flash Type)										
64G: 64GB					A28: 128GB						S: Single Channel										
B56: 256GB					C12: 512GB						D: Dual Channels										
01T: 1TB																					
Code 10th ~12th (Controller)											Code 19th ~21st (Customize code)										
IC1: SATA 3TEB											F: Kioxia 3D TLC										
Code 13th (Flash mode)											Code 19th ~21st (Customize code)										
K: 112 layers 3D TLC																					