

R19MG3S-67FTP(HB)

19-inch G-WIN Full IP67 P-CAP Panel PC with ARM A78 + A55 Processor



KEY FEATURES

- ARM 2 x A78 2.0GHz + 4 x A55 2.0GHz
- 19-inch sunlight viewable 1000 nits LCD panel
- Optical Bonding with Panel & Touch Screen to increase the clarity and transparency
- Touch screen control button to enable/disable touch screen interface
- Front control membrane keys Lockable by software
- Dust/ Water proof design Full IP67 Panel PC
- Fanless, streamlined enclosure for highly efficient heat dissipation
- Rugged Front Anti-Impact Design
- 10 to 55°C wide operating temperature
- Wide Range 9 to 36V DC Input with isolation. Optional for Ignition On/Off delay

INTRODUCTION

Winmate G-WIN IP67 Panel PC Series is designed to excel in demanding environments, offering a versatile range of display sizes from 7" to 21.5" and supporting both Windows and Android operating systems. Engineered for durability and performance, these Panel PCs feature advanced PCAP touch technology, optical bonding for enhanced visibility, and rugged aluminum housing. With a full IP67 rating for complete protection against water and dust, they are ideal for industrial and outdoor applications. The series also supports VESA mount solutions for flexible installation and offers optional high-brightness displays for optimal readability in bright conditions.

SPECIFICATIONS

System Specification

Processor	ARM 2 x A78 2.0GHz + 4 x A55 2.0GHz	Memory	4GB LPDDR4
Storage	Onboard 32 GB	Operating System	Android 13 Linux Yocto 5.10.104 with QT 5.15 (Optional) Linux Ubuntu 22.04 (Optional)
WLAN	Support (Optional)	BT	Support (Optional)

Display

Resolution	1280x1024	Size	19.0 inches
Contrast Ratio	1000:1	Panel Brightness	1000.0 nits
View Angles	85,85,80,80	Type	Projected Capacitive Multi Touch Screen Bonding With Panel

Mechanical

Dimension	474 x 410 x 111 mm	Weight	9.8 kg
Mounting	Panel mount VESA mount (Optional)	Enclosure	Aluminum Housing
Cooling System	Fanless Design		

Environment

Operating Humidity	10% to 90% RH, Non-Condensing	Operating Temperature	-10°C to 55°C -40°C to 70°C (with intelligent heater)
Storage Temperature	-30°C to 70°C	Shock	MIL-STD-810G Method 516.6 Procedure I
Vibration	MIL-STD-810G Method 514.6 Procedure I	IP rating	IP67

Certification

Certification	CE, FCC
----------------------	---------

IO Ports

Power Input	1 x M12 waterproof connector for 9~36V DC	USB Port	1 x M12 waterproof connector for 2 x USB2.0 1 x Waterproof USB Type-A Connector with cover
Serial Port	1 x M12 waterproof connector for RS232	LAN	1 x waterproof Giga LAN RJ45 connector
Indicator	1 x LED Indicator for power 1 x LED Indicator for storage 1 x LED Indicator for heater 1 x LED Indicator for LAN 1 x LED Indicator for lock touch		

Control

Button	1 x Power Button 1 x Brightness up Button 1 x Brightness down Button 1 x Button for locking touch function 1 x Programmable function key
---------------	--

Accessory

Accessory	External open wire Power cable with waterproof connector External USB cable with waterproof connector External COM cable with waterproof connector External LAN cable with waterproof connector Waterproof caps RJ45 female-female converter USB Type A converter Mounting clips VESAs screws	Optional Accessory	100~240V AC to DC 120W Adapter with power cord (Optional)
------------------	---	---------------------------	---

DIMENSIONS UNIT:MM

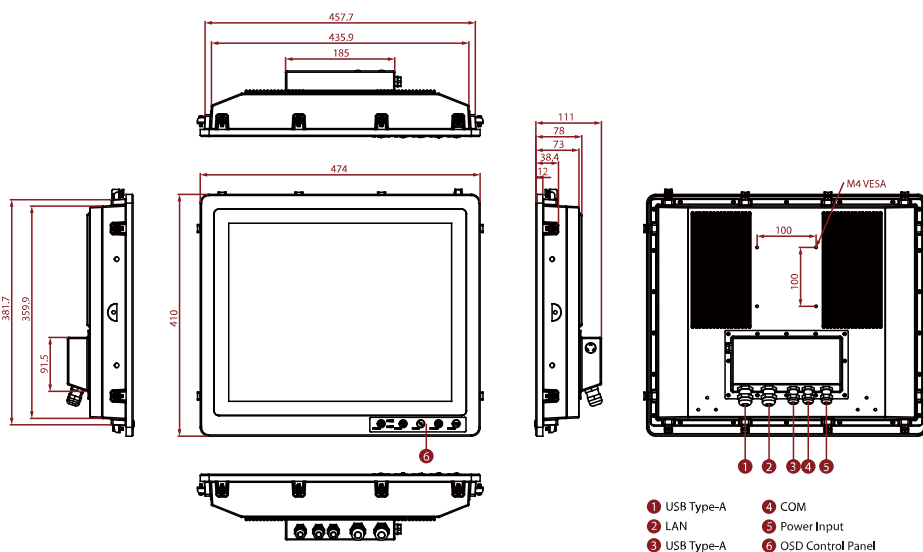

NOTE

1. This is a simplified drawing and some components are not marked in detail.
2. Weight of the device varies by configuration.
3. Please contact our sales representative if you need further product information.
4. All specifications are subject to change without prior notice.
5. The product shown in this datasheet is a standard model. For diagrams that contain customized or optional I/O, please contact the Winmate Sales Team for more information.