

# 規格書

## SPECIFICATION

品名  
STYLE NAME : REDUNDANT SWITCHING POWER SUPPLY

型號  
MODEL NO. : M1R2-5600K2H

料號  
PART NO. :

版次  
REVISION : A3

APPROVE 核准	張裕淵	正 式 資 料 用 章	
CHECK BY 審核	張恒嘉		
FORM MAKER 經辦	陳品文		



新巨企業股份有限公司  
ZIPPY TECHNOLOGY CORP.

10F, NO.50 MIN CHYUAN RD., SHIN-TIEN CITY, TAIPEI HSIEN, TAIWAN, R.O.C.  
TEL. : +886(2)29188512 FAX. : +886(2)29134969  
<http://www.zippy.com.tw> E-MAIL: [powersales@zippy.com.tw](mailto:powersales@zippy.com.tw)



## Revision

Rev.	Page	Item	Date	Description
A2	15	10.0	JUN-20-2016	Update Output power derating characteristics
A3	7	3.3	AUG-25-2016	Update Ripple and noise



# **MODEL NO. M1R2-5600K2H**

## 1.0 SCOPE

### 2.0 Input requirements

- 2.1 AC Input Voltage, Frequency and Current
- 2.2 AC Inrush Current
- 2.3 Power factor correction / Current Harmonics
- 2.4 Efficiency
- 2.5 AC Line Dropout
- 2.6 AC Line Transient Specification
- 2.7 AC Line Fast Transient Specification

### 3.0 Output requirements

- 3.1 Output Current / Loading
- 3.2 DC Voltage Regulation
- 3.3 Ripple and noise
- 3.4 Dynamic Loading
- 3.5 Capacitive Loading
- 3.6 Timing Requirements
- 3.7 Remote on / off control
- 3.8 Overshoot at Turn-on / Turn-off
- 3.9 standby Outputs

### 4.0 Protection

- 4.1 Over power protection
- 4.2 Over voltage protection
- 4.3 Over current protection
- 4.4 Short Circuit Protection

### 5.0 Environmental Requirements

- 5.1 Temperature
- 5.2 Humidity
- 5.3 Altitude

### 6.0 Safety

- 6.1 UL
- 6.2 CUL
- 6.3 TUV
- 6.4 CCC
- 6.5 Power Line Transient
- 6.6 RFI / EMI Standards
- 6.7 Leakage current
- 6.8 Production Line Testing
- 6.9 Hi-Pot Testing
- 6.10 Insulation resistance

## 7.0 Reliability

### 7.1 Burn in

### 7.2 MTBF

## 8.0 Mechanical requirements

## 9.0 Redundant Function

### 9.1 Hot Swap Requirements

### 9.2 LED INDICATORS

### 9.3 TTL INDICATORS.

## 10.0 Output power derating characteristics



## 1.0 Output power derating characteristics\_Scope

This specification defines the performance characteristics of a grounded, Ac input,600 watts, 5 output level power supply. This specification also defines world wide safety requirements and manufactures process test requirements.

M1R2-5600K2H power system is a 1+1 Redundant power system consisting of two M1R-2600K2 power modules and one M1R2-5600K2H power system frame.

## 2.0 Input requirements

### 2.1 AC Input Voltage, Frequency and Current (Rating: 100V-240Vac, 47-63Hz, 8-4A)

Parameter	Minimum	Rated	Maximum	Max. Current
Voltage (115V)	90 Vac	100-127Vac	132 Vac	8 A
Voltage (230V)	180 Vac	200-240Vac	264Vac	4 A
Frequency	47 Hz	50 / 60 Hz	63 Hz	

Table 1 – AC Input Voltage , Frequency and Current

### 2.2 AC Inrush Current (Per power module)

AC line inrush current shall not damage any component nor cause the AC line fuse to blow under any DC conditions and with any specified AC line input voltage and frequency. Repetitive On/Off cycling of the AC input voltage shall not damage the power supply.

15/30 amps @115/230 VAC (at 25 degrees ambient cold start for each power unit)  
High-Frequency peak amplitudes lasting less than 50uS (i.e.those caused by EMI capacitors)shall be ignored.

### 2.3 Power factor correction / Current Harmonics

The power supply modules shall incorporate universal power input with active power

factor correction, which shall reduce the line harmonics in accordance with the EN61000-3-2 CLASS "D" standards.

PFC:up to the target of 95% @115V, full load.

### 2.4 Efficiency (Per power module)

The maximum power supply system efficiency shall be 88%, measured at nominal input voltage 230 V and full loading.

#### NOTE:

The different harness conditions and/or the accuracy of measurement instruments affect the test result of output voltage and efficiency. Harness conditions are such as cable length, wire gauge, the connector types, total harness amounts.

## 2.5 AC Line Dropout

An AC line dropout of 9ms or less shall not cause any tripping of control signals or protection circuits.

If the AC dropout lasts longer than 9mS the power supply should recover and meet all turn on requirements. The power supply shall meet the regulation requirement over all rated AC voltages, frequencies, and output loading conditions. Any dropout of the AC line shall not cause damage to the power supply. An AC line dropout is defined as a drop in AC line to 0VAC at any phase of the AC line for any length of time.

## 2.6 AC Line Transient Specification

AC line transient conditions shall be defined as “sag” and “surge” conditions. Sag conditions (also referred to as “brownout” conditions) will be defined as the AC line voltage dropping below nominal voltage. Surge will be defined as the AC line voltage rising above nominal voltage.

## 2.7 AC Line Fast Transient Specification

The power supply shall meet the EN61000-4-5 directive and any additional requirements in IEC1000-4-5:1995 and the Level 3 requirements for surge-withstand capability, with the following conditions and exceptions:

- These input transients must not cause any out-of-regulation conditions, such as overshoot and undershoot, nor must it cause any nuisance trips of any of the power supply protection circuits.
- The surge-withstand test must not produce damage to the power supply.
- The supply must meet surge-withstand test conditions under maximum and minimum DC-output load conditions.

## 3.0 Output requirements

### 3.1 Output Current / Loading

The Table 2 define current rating. The power supply shall meet both static and dynamic voltage regulation requirements for minimum load condition

Output	+5V	+3.3V	+12V	-12V	+5VS
Max. Load	22A	22A	50A	0.5A	3 A
Min. Load	0A	0A	2A	0A	0.1A

Table 2 – Output Current:  
+5V and +3.3V Max. power:150W  
Total power:600W (MAX)

### 3.2 DC Voltage Regulation

The power supply output voltages must stay within the following voltage limits when operating at steady state and dynamic loading conditions. All outputs are measured with reference to the return remote sense (ReturnS) signal. The +5V, +12V, -12V and +5VSB outputs are measure at the power supply connectors' references to ReturnS. The +5V and +3.3V is measured at its remote sense signal (+5VS+, +3.3VS+) located at the signal connector.

Output Voltage	+5V	+3.3V	+12V	-12V	+5VSB
Load Reg.	+5/-5%	+5/-5%	+5/-5%	+5/-5%	+5/-5%
Line Reg.	±1%	±1%	±1%	±1%	±1%

Table 3 – Regulation

### 3.3 Ripple and noise

The maximum allowed ripple/noise output of the power supply is defined in Table 4.

This is measured over a bandwidth of 0 Hz to 20 MHz at the power supply output connectors. A 100µF tantalum capacitor in parallel with a 0.1 µF ceramic capacitor are placed at the point of measurement.

Output Volatage	Ripple	Ripple+Noise
+5V	50mV(P-P)	50mV(P-P)
+12V	120mV(P-P)	120mV(P-P)
-12V	120mV(P-P)	120mV(P-P)
+3.3V	50mV(P-P)	50mV(P-P)
+5Vsb	50mV(P-P)	50mV(P-P)

\* For Ripple & Noise condition +12V min loading is 6A.

Table 4 - Ripple and noise

### 3.4 Dynamic Loading

The output voltages shall remain within the limits specified in Table 5 for the step loading and within the limits specified in Table 6 for the capacitive loading. The load transient repetition rate shall be tested between 50Hz and 5kHz at duty cycle ranging from 10%-90%. The load transient repetition rate is only a test specification. The  $\Delta$  step load may occur anywhere within the MIN load to the MAX load range.

Output	$\Delta$ Step Load Size	Load Slew Rate	Capacitive Load
+3.3 V	6.6A	0.5 A/µs	1000 µF
+5 V	6.6A	0.5 A/µs	1000 µF
12V	25A	0.5 A/µs	2200 µF
+5 VSB	0.75A	0.5 A/µs	1 µF

Table 5 – Transient Load Requirements

**MODEL NO:**  
M1R2-5600K2H



新巨企業股份有限公司  
ZIPPY TECHNOLOGY CORP.

Page: 8 of 16  
Revision:A3





### 3.5 Capacitive Loading

The power supply shall be stable and meet all requirements with the Table 6 capacitive loading ranges.

Output	MIN	MAX	Units
+3.3 V	10	12,000	μF
+5 V	10	12,000	μF
+12 V	10	11,000	μF
-12 V	1	350	μF
+5 VSB	1	350	μF

Table 6 – Capacitive Loading Conditions

### 3.6 Timing Requirements

These are the timing requirements for the power assembly operation. The output voltages must rise from 10% to within regulation limits ( $T_{vout\_rise}$ ) within 0 to 20ms. The +5V, +3.3V and +12V output voltages should start to rise at about the same time. All outputs must rise monotonically. The +5V output needs to be greater than the +3.3V output during any point of the voltage rise. The +5V output must never be greater than the +3.3V output by more than 2.25V. Each output voltage shall reach regulation within 50 ms ( $T_{vout\_on}$ ) of each other during turn on of the power supply. Each output voltage shall fall out of regulation within 400 ms ( $T_{vout\_off}$ ) of each other during turn off. Figure 1 and figure 2 show the turn On and turn Off timing requirement. In Figure 2, the timing is shown with both AC and PSON# controlling the On/Off of the power supply.

Item	Description	MIN	MAX	Units
$T_{vout\_rise}$	Output voltage rise time from each main output.		20	ms
	Output voltage rise time for the 5VSB output.		25	ms
$T_{vout\_on}$	All main outputs must be within regulation of each other within this time.		50	ms
$T_{vout\_off}$	All main outputs must leave regulation within this time.		400	ms

Table 7 – Output Voltage Timing

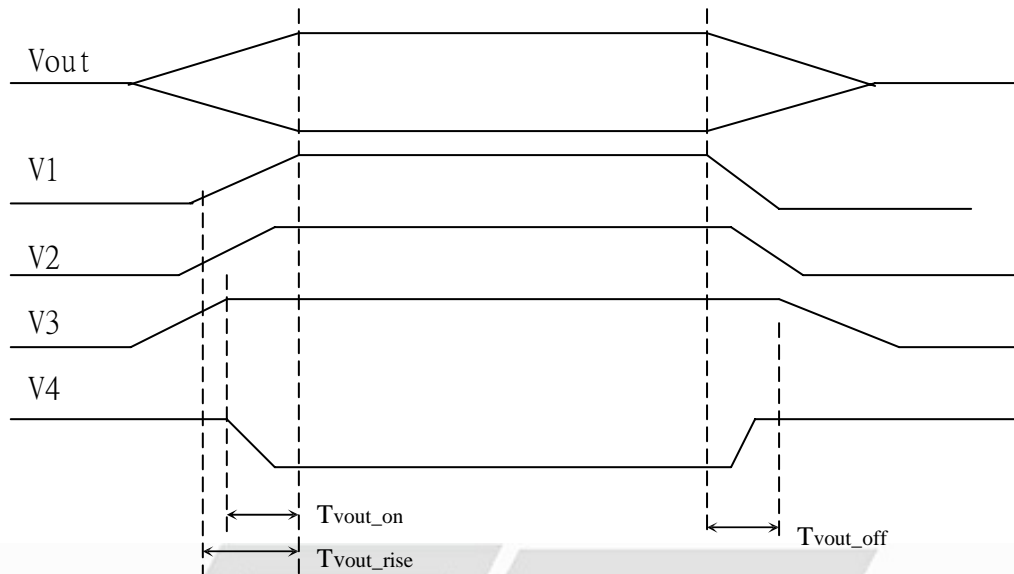

Figure 1: Output Voltage Timing

Item	Description	MIN	MAX	UNITS
Tsb_on_delay	Delay from AC being applied to 5VSB being within regulation.		1500	ms
Tvout_rise	Output voltage rise time from each main output.		20	ms
Tac_on_delay	Delay from AC being applied to all output voltages being within regulation.		2500	ms
Tsb_vout	Delay from 5VSB being in regulation to O/Ps being in regulation at AC turn on.	5	1000	ms
Tpwok_on	Delay from output voltages within regulation limits to PWOK asserted at turn on.	100	500	ms
Tpwok_holdup	Delay from loss of AC to deassertion of PWOK.	8		ms
Tvout_holdup	Time all output voltages stay within regulation after loss of AC.	9		ms
Tsb_holdup	Time 5VSB output voltage stays within regulation after loss of AC.	70		ms
Tpson_on_delay	Delay from PSON# active to output voltages within regulation limits.	5	400	ms
Tpson_pwok	Delay from PSON# deactive to PWOK being deasserted.		50	ms

Table 8 – Turn On/Off Timing

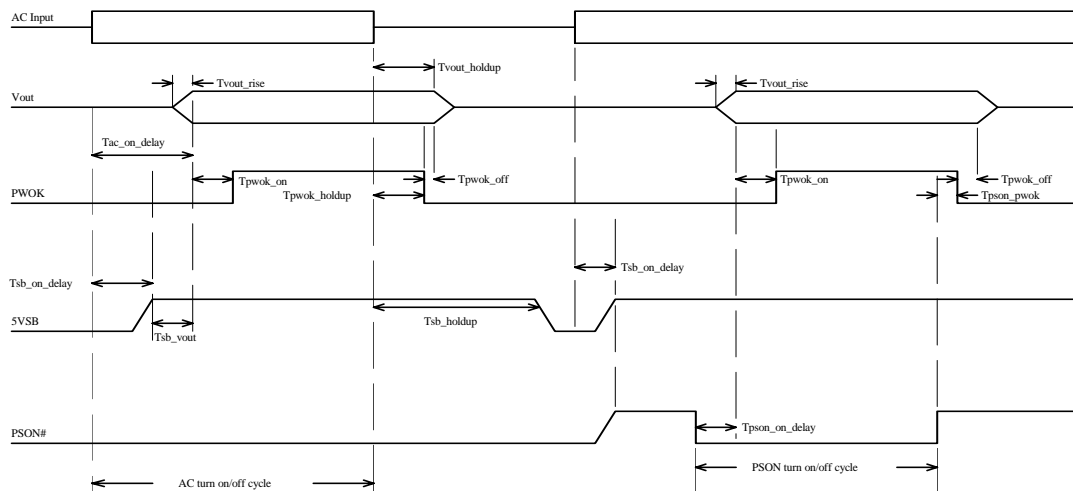

Figure 2: Turn On/Off Timing(Power Supply)

### 3.7 Remote on/off control

The PSON# signal is required to remotely turn on/off the power supply. PSON# is an active low signal that turns on the +5V, +3.3V, +12V and -12V power rails. When this signal is not pulled low by the system, or left open, the outputs (except the +5VSB) turn off. This signal is pulled to a standby voltage by a pull-up resistor internal to the power supply. Refer to Figure 2 for timing diagram.

Signal Type	Accepts an open collector/drain input from the system. Pull-up to VSB located in power supply.	
PSON# = Low	ON	
PSON# = Open or High	OFF	
	MIN	MAX
Logic level low (power supply ON)	0 V	1.0 V
Logic level high (power supply OFF)	2.0 V	5.25 V
Source current, Vpson = low		4 mA
Power up delay: Tpsn_on_delay	5 ms	400 ms
PWOK delay: Tpsn_pwok		50 ms

Table 9 – PSON# Signal Characteristic

### 3.8 Overshoot at Turn-on / Turn-off

Any output overshoot at turn on shall be less than 10% of the nominal output value.

Any overshoot shall recover to within regulation in less than 10ms.

### 3.9 standby outputs

The 5VSB output shall be present when an AC input greater than the power supply turn on voltage is applied.

#### 4.0 Protection

Protection circuits inside the power supply shall cause only the power supply's main outputs to shutdown. If the power supply latches off due to a protection circuit tripping, either a AC cycle OFF for 15 sec, or PSON# cycle HIGH for 1 sec must be able to restart the power supply.

##### 4.1 Over power protection

The power supply shall provide over power protection on the power supply latches all DC output into a shutdown state. Over power of this type shall cause no damage to power supply, after over load is removed and a power on/off cycle is initiated, the power supply will restart.

Trigger point total power min. 110%, max. 150%.

##### 4.2 Over voltage protection(Per Power Module)

The power supply shall shut down in a latch off mode when the output voltage exceeds the over voltage limit shown in Table 10.

Voltage	Minimum	Maximum	Shutdown
+3.3	+3.7V	+4.1V	Latch Off
+5V	+5.7V	+6.5V	Latch Off
+12V	+12.8V	+14.9V	Latch Off

Table 10 -Over Voltage Protection

##### 4.3 Over current protection(Per Power Module)

This power supply shall have current limit to prevent the +12V outputs from exceeding the values shown in Table 11. The current limit shall not trip under maximum continuous load or peak loading as described in Table 5. The power supply shall latch off if the current exceeds the limit. The latch shall be cleared by toggling the PSON# signal or by cycling the AC power. The power supply shall not be damaged from repeated power cycling in this condition. The -12V and +5VSB outputs shall be shorted circuit protected so that no damage can occur to the power supply.

Voltage	Minimum	Maximum	Shutdown
+12V	110%	150%	Latch Off

Table 11 – Over Current Protection

##### 4.4 Short Circuit Protecton

4.3.1: A short circuit placed on any DC output to DC return shall cause no damage.

4.3.2: The power supply shall be latched in case any short circuit is taken place at +5V,+3.3V,+12V, output.

4.3.3: The power supply shall be auto-recovered in case any short circuit is taken place at +5VSB.

## 5.0 Environmental Requirements

### 5.1 Temperature

Operating Temperature Range:	0°C ~ 50°C
Non-Operating Temperature Range:	-20°C ~ 80°C

### 5.2 Humidity

Operating Humidity Range:	20% ~ 80%RH non-condensing
Non-Operating Humidity Range:	10% ~ 90%RH non-condensing

### 5.3 Altitude

Operating Altitude Range:	Sea level to 16,000 ft
Non-Operating Altitude Range:	Sea level to 40,000 ft

## 6.0 Safety

The power supply must be certified to the safety standard listed following:

### 6.1 Underwriters laboratory (UL).

The power supply designed to meet UL 60950.

### 6.2 Canadian standards association (CUL)

The power supply designed to meet CSA C22.2 No. 60950.

### 6.3 TUV

The power supply shall be designed to meet TUV EN-60950.

### 6.4 CCC Standards

The power supply shall be designed to meet GB9254-2008, GB4943.1-2011, GB17625.1-2012.

### 6.5 Power Line Transient.

The power supply shall be designed to meet the following standards

- a.) EN 61000-4-2(ESD) Criterion B,  $\pm 4\text{KV}$  by contact,  $\pm 8\text{KV}$  by air.
- b.) EN 61000-4-4(EFT) Criterion B,  $\pm 1\text{KV}$ .
- c.) EN 61000-4-5(SURGE) Criterion B, Line-Line  $\pm 1\text{KV}$   
Line-Earth  $\pm 2\text{KV}$ .

### 6.6 RFI / EMI Standards

The power supply shall comply with the following radiated and conducted Emissions standards,

- a.) FCC part 15. class A.
- b.) CISPR 22 (EN 55022). class A.

### 6.7 Leakage current

Input leakage current from line to ground will be less than 3.5mA rms. Measurement will be made at 240 VAC and 60Hz.

### 6.8 Production Line Testing

100% of the power supply production must have the following test performed. Each power shall be marked indicating the testing was done and passed. Typically this is done by stamping or labeling the power supply with “Hi-pot test OK”.

### 6.9 Hi-Pot Testing

Primary to secondary	: 3000 VAC for 60 sec.
Primary to FG	: 1500 VAC for 60 sec.
For production purpose:	
Primary to FG	:1500VAC for 1 sec.

### 6.10 Insulation resistance

Primary to secondary	: 20 meg. Ohm min. 500 VDC
Primary to FG	: 20 meg. Ohm min. 500VDC

## 7.0 Reliability

### 7.1 Burn in

All products shipped to customer must be burn in. The burn in shall be performed at high line voltage.

### 7.2 MTBF

The MTBF of the power supply shall be calculated utilizing the Part-Count Analysis method of MIL-HDBK-217F.

The calculated MTBF of the power supply is 259429 hours at ambient temperature 25 degree. anical requirements

## 8.0 Mechanical requirements

Physical dimension :295mm (D ) x106mm (W) x 41.3mm (H)

## 9.0 Redundant Function

### 9.1 Hot Swap Requirements

The redundant power supply modules shall be hot swappable. Hot swapping a power supply is the process of inserting and extracting a power supply from an operating. During this process the output voltage shall remain within the limits specified in Table 3 with the capacitive load specified Table 5. The Sub-system shall not exceed the maximum inrush current as specified in section 2.2. The power supply can be hot swapped by the following methods:

● AC connecting separately to each module. Up to two power supplies may be on a single AC power source.

Extraction: The AC power will be disconnected from the power supply first and then the power supply is

Extracted from the sub-system. This could occur in standby mode or powered on mode. Insertion: The module is inserted into the cage and then AC power will be connected to the power supply module.

● For power modules with AC docking at the same time as DC. Extraction: The module is extracted from the cage and both AC and DC disconnect at the same Time. This could occur in standby or power on mode. No damage or arcing shall occur to the DC or AC contacts which could cause damage. Insertion: The AC and DC connect at the same time as the module is inserted into the cage. No damage to the connector contacts shall occur. The module may power on or come up into standby mode.

Many variations of the above are possible. Supplies need to be compatible with these different variations depending upon the sub-system construction. In general, a failed (off by internal latch or external control) supply may be removed, then replaced with a good power supply (must use the same model), however, hot swap needs to work with operational as well as failed power supplies. The newly inserted power supply may get turned on by inserting the supply into the system or by system management recognizing an inserted supply and explicitly turning it on.

## 9.2 LED INDICATORS

There shall be a single Green LED on power cage to indicate power supply status. The GREEN LED shall turn ON to indicate that all the power outputs are available or one module is dummy. The LED shall be Turn off to indicate that one module has failed or shutdown due to protection.

## 9.3 TTL INDICATORS

There shall be an open-collect TTL to indicate power supply status. The TTL shall pull high to 5.0v indicate that all the power outputs are available or one module is dummy. The TTL shall pull low (under 1.0v) indicate that the one module has failed or shutdown due to protection.

### 10.0 Output power derating characteristics

Total max.  
output Power

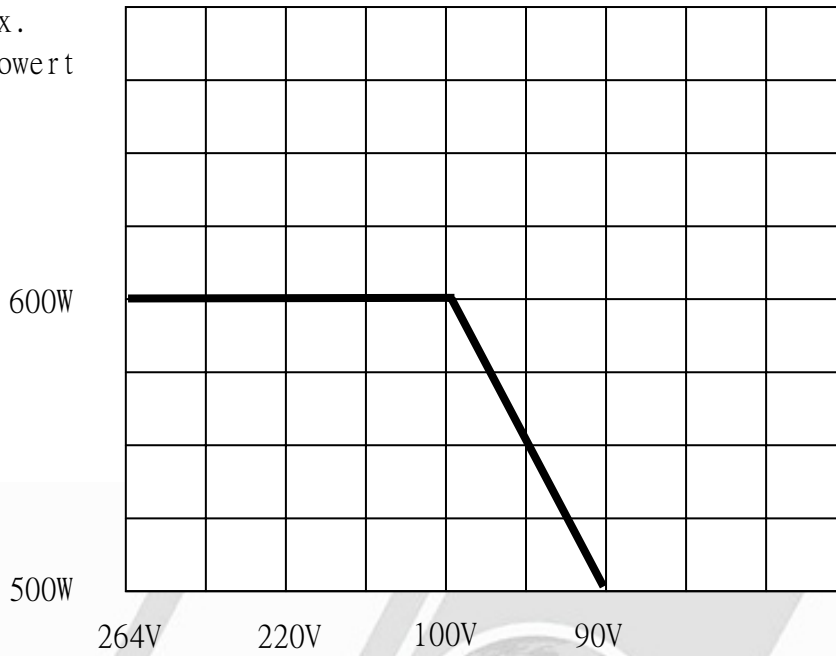

Total max.  
output Power

