

規格書

SPECIFICATION

品名 SWITCHING POWER SUPPLY
STYLE NAME :

型號 BHG2-5300V
MODEL NO. :

料號
PART NO. :

版次 A3
REVISION :

APPROVE 核准	黃永欣	正式 資料 用 章	
CHECK BY 審核	王建評		
FORM MAKER 經辦	曾芳靜		

新巨企業股份有限公司
電源事業處
ZIPPY TECHNOLOGY CORP.
POWER DIVISION

10F, NO. 50 MIN CHYUAN RD.,
SHIN-TIEN CITY, TAIPEI HSIEN,
TAIWAN, R.O.C.
TEL. : +886(2)29188512
FAX. : +886(2)29134969

Revision

Rev.	Page	Item	Date	Description
A2	5	2.1	JUN-16-2011	Update Voltage
A3	5	2.1	APR-16-2013	Update Input Voltage

MODEL NO. BHG2-5300V

- 1.0 Scope
- 2.0 Input requirements
 - 2.1 Voltage
 - 2.2 Steady-state current
 - 2.3 Inrush current
- 3.0 Output requirements
 - 3.1 DC load requirements
 - 3.2 Regulation
 - 3.3 Ripple and noise
 - 3.3.1 Specification
 - 3.3.2 Ripple voltage test circuit
 - 3.4 Overshoot
 - 3.5 Efficiency
- 4.0 Protection
 - 4.1 Input
 - 4.2 Output
 - 4.2.1 OPP
 - 4.2.2 OVP
 - 4.2.3 Short current
 - 4.2.4 OCP
- 5.0 Power supply sequencing
 - 5.1 Turn on
 - 5.2 Hold up time
 - 5.3 Power off sequence
- 6.0 Signal requirements
 - 6.1 Power good signal
- 7.0 Environment
 - 7.1 Temperature
 - 7.2 Humidity
 - 7.3 Insulation resistance
 - 7.4 Dielectric withstanding voltage
- 8.0 Safety
 - 8.1 UL
 - 8.2 TUV
 - 8.3 CB
- 9.0 Reliability
 - 9.1 Burn in

10.0 Mechanical requirements

11.0 DC output cable drawing

1.0 Scope

This specification defines the performance characteristics of a grounded 300 watts , 5 output level power supply. This specification also defines world wide safety requirements and manufactures process test requirements.

2.0 Input requirements

2.1 Voltage

Range 18 ~ 36 VDC

Nomal 24VDC

2.2 Steady-state current

18 ~ 36 VDC / 22~11 amp (16 amp at 24VDC)

2.3 Inrush current

50 amps @ 24VDC (at 25 degrees ambient cold start)

3.0 Output requirements

3.1 DC load requirements

Normal Output voltage	Load current		Regulation tolerance	
	Max.	Min	Max.	Min.
+5V	25.0	1	+5%	-5%
+12V	25.0	2.0	+5%	-5%
-12V	0.8	0.0	+10%	-10%
+3.3V	25.0	0.5	+5%	-5%
+5VSB	2.5	0.1	+5%	-5%

*** +5V and +3.3V total output max : 30A ***

*** Total output max : 300W ***

When doing the cross regulation test(one output channel at high load and the other output channels at low load), it is requested to set the higher output channel at 80% max. of its spec., and the lower output channels at 20% max. of theirs.

3.2 Regulation

Output DC voltage	Line regulation
+5V	±50mV
+12V	±120mV
-12V	±120mV
+3.3V	±50mV
+5VSB	±50mV

3.3 Ripple and noise

3.3.1 Specification

+5V	50mV (P-P)
+12V	120mV (P-P)
-12V	120mV (P-P)
+3.3V	50mV (P-P)
+5VSB	50mV (P-P)

3.3.2 Ripple voltage test circuit

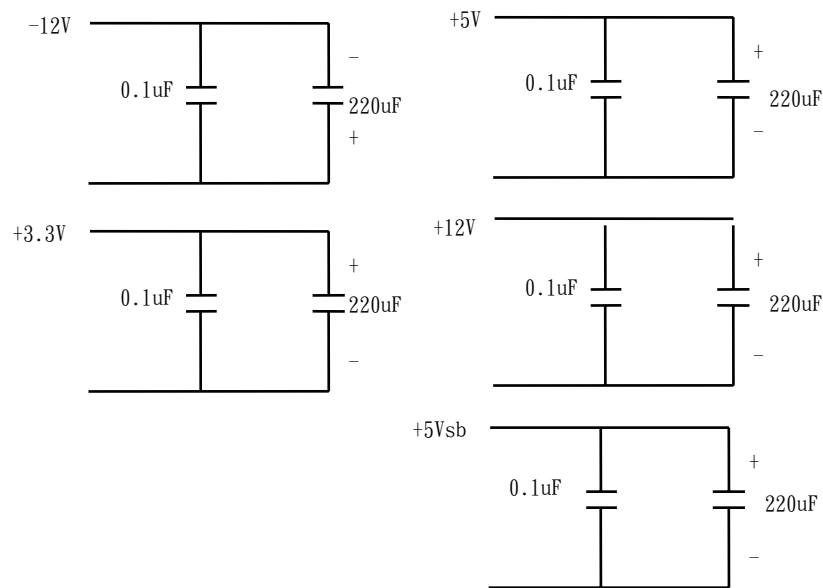

0.1uF is ceramic, the other is electrolytic capacitor.

Noise bandwidth is from DC to 20Mhz

3.4 Overshoot

Any overshoot at turn on or turn off shall be less than 10% of the nominal voltage value , all output shall be within the regulation limit of section 3.1 before issuing the power good signal of section 6.0.

3.5 Efficiency

Power supply efficiency >80% at 24V , full load.

(Any difference either on the DC output cable (i.e., length, wire gauge) or on the accurate of instruments will conclude different test result. It will affects output voltage and efficiency.)

4.0 Protection

4.1 Input (primary)

The input power line must have an over power protection device in accordance with safety requirement of section 8.0

4.2 Output (secondary)

4.2.1 Over power protection (one unit)

The power supply shall provide over power protection on the power supply latches all DC output into a shutdown state. Over power of this type shall cause no damage to power supply , after over load is removed and a power on/off cycle is initiated , the power supply will restart.

Trip point total power min. 130% , max. 170%.

4.2.2 Over voltage protection

If an over voltage fault occurs , the power supply will latch all DC output into a shutdown state before

+5V : 5.6V ~ 6.5V
 +3.3V : 3.6V ~ 4.3V
 +12V : 13.2V ~ 15 V

4.2.3 Short circuit

A: A short circuit placed on any DC output to DC return shall cause no damage.

B: The power supply shall be latched in case any short circuit is taken place at +5V,+3.3V,+12V,-12V output.

C: The power supply shall be auto-recovered in case any short circuit is taken place at +5VSB.

4.2.4 Over current protection

If an over current fault occurs , the power supply will latch all DC output into a shutdown state.

	Min	Typical	Max
+3.3V	28A	32.5A	40A
+5V	28A	32.5A	40A
+12V	36A	43A	49.5A

5.0 Power supply sequencing

5.1 Power on (see fig.1)

5.2 Hold up time

When power shutdown DC output 12V must be maintain 1mS in regulation limit at normal input voltage.

5.3 Power off sequence (see fig. 1)

6.0 Signal requirements

6.1 Power good signal (see fig. 1)

The power supply shall provide a "power good" signal to reset system logic , indicate proper operation of the power supply.

At power on , the power good signal shall have a turn on delay of at least 100ms but not greater than 500ms after the output voltages have reached their respective minimum sense levels.

7.0 Environment

7.1 Temperature

Operating temperature	0 to 40 degrees centigrade
Non-Operating temperature	-20 to 80 degrees centigrade

Operating temperature from 0°C should start from DC 24V

7.2 Humidity

Operating humidity	20% to 80%
Non-operating humidity	10% to 90%

7.3 Insulation resistance

Primary to secondary	: 20 meg. ohm min. 500 VDC
Primary to Frame Gnd	: 20 meg. ohm min. 500 VDC

7.4 Dielectric withstanding voltage

For approval purpose :

Primary to secondary	: 1.5K VAC for 1 sec.
Primary to Frame Gnd	: 1.5K VAC for 1 sec.

8.0 Safety

8.1 Underwriters laboratory (UL).

The power supply designed to meet UL 60950.

8.2 TUV Standards

The power supply shall be designed to meet TUV EN-60950.

8.3 CB

The power supply shall be designed to meet CB IEC 60950.

9.0 Reliability

9.1 Burn in

All products shipped to customer must be processed by burn-in. The burn- in shall be performed at full load.

10.0 Mechanical requirements

Physical dimension : 140 mm * 150 mm * 86 mm (D*W*H)

11.0 DC output cable drawing
(see attached drawing)

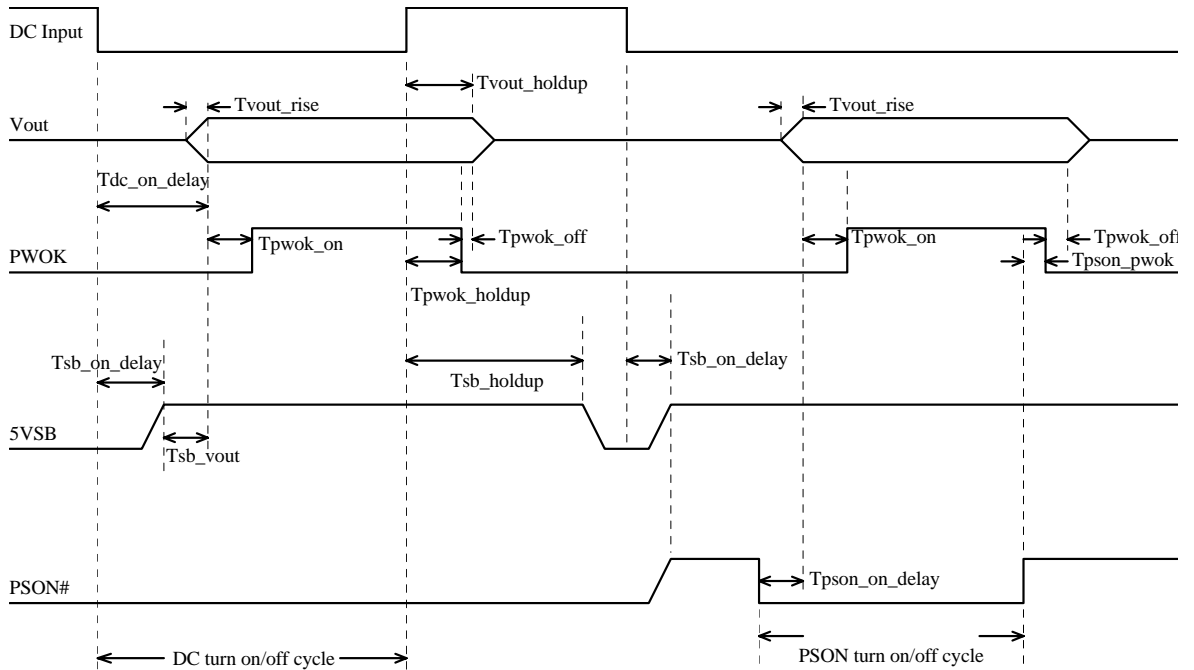

Item	Description	MIN	MAX	UNITS
Tsb_on_delay	Delay from DC being applied to 5VSB being within regulation.		2500	ms
Tdc_on_delay	Delay from DC being applied to all output voltages being within regulation.		4000	ms
Tvout_holdup	Time all output voltages stay within regulation after loss of DC.	1.6		ms
Tpwok_holdup	Delay from loss of DC to deassertion of PWOK.	0.6		ms
Tpsn_on_delay	Delay from PSON# active to output voltages within regulation limits.	5	400	ms
Tpsn_pwok	Delay from PSON# deactive to PWOK being deasserted.		50	ms
Tpwok_on	Delay from output voltages within regulation limits to PWOK asserted at turn on.	100	500	ms
Tpwok_off	Delay from PWOK deasserted to output voltages (3.3V, 5V, 12V, -12V) dropping out of regulation limits.	1		ms
Tsb_vout	Delay from 5VSB being in regulation to O/Ps being in regulation at DC turn on.	5	1000	ms
Tsb_holdup	Time 5VSB output voltage stays within regulation after loss of DC.	2		ms
Tvout_rise	Output voltage rise time from each main output.	5	20	ms

《Figure 1》