

# M.2 (S80)

## 3MG5-P Series

**Customer:** \_\_\_\_\_

**Customer**

**Part**

**Number:** \_\_\_\_\_

**Innodisk**

**Part**

**Number:** \_\_\_\_\_

**Innodisk**

**Model Name:** \_\_\_\_\_

**Date:** \_\_\_\_\_

<b>Innodisk Approver</b>	<b>Customer Approver</b>

**Total Solution For  
Industrial Flash Storage**

## Table of contents

<b>1. PRODUCT OVERVIEW</b> .....	7
<b>1.1 INTRODUCTION OF INNODISK M.2 (S80) 3MG5-P</b> .....	7
<b>1.2 PRODUCT VIEW AND MODELS</b> .....	7
<b>1.3 SATA INTERFACE</b> .....	7
<b>2. PRODUCT SPECIFICATIONS</b> .....	8
<b>2.1 CAPACITY AND DEVICE PARAMETERS</b> .....	8
<b>2.2 PERFORMANCE</b> .....	8
<b>2.3 ELECTRICAL SPECIFICATIONS</b> .....	9
<b>2.3.1 Power Requirement</b> .....	9
<b>2.3.2 Power Consumption</b> .....	9
<b>2.4 ENVIRONMENTAL SPECIFICATIONS</b> .....	9
<b>2.4.1 Temperature Ranges</b> .....	9
<b>2.4.2 Humidity</b> .....	9
<b>2.4.3 Shock and Vibration</b> .....	9
<b>2.4.4 Mean Time between Failures (MTBF)</b> .....	9
<b>2.5 CE AND FCC COMPATIBILITY</b> .....	10
<b>2.6 RoHS COMPLIANCE</b> .....	10
<b>2.7 RELIABILITY</b> .....	10
<b>2.8 TRANSFER MODE</b> .....	10
<b>2.9 PIN ASSIGNMENT</b> .....	11
<b>2.10 MECHANICAL DIMENSIONS</b> .....	13
<b>2.11 ASSEMBLY WEIGHT</b> .....	14
<b>2.12 SEEK TIME</b> .....	14
<b>2.13 HOT PLUG</b> .....	14
<b>2.14 NAND FLASH MEMORY</b> .....	14
<b>3. THEORY OF OPERATION</b> .....	15
<b>3.1 OVERVIEW</b> .....	15
<b>3.2 SATA III CONTROLLER</b> .....	15
<b>3.3 RAID PROTECTION</b> .....	15
<b>3.4 ERROR DETECTION AND CORRECTION</b> .....	16
<b>3.5 WEAR-LEVELING</b> .....	16
<b>3.6 BAD BLOCKS MANAGEMENT</b> .....	16
<b>3.7 iDATA GUARD</b> .....	16
<b>3.8 GARBAGE COLLECTION/TRIM</b> .....	16
<b>3.9 THERMAL SENSOR</b> .....	16
<b>3.10 TRIM</b> .....	17
<b>4. INSTALLATION REQUIREMENTS</b> .....	18

- 4.1 M.2 (S80) 3MG5-P PIN DIRECTIONS ..... 18**
- 4.2 ELECTRICAL CONNECTIONS FOR M.2 (S80) 3MG5-P..... 18**
- 4.3 DEVICE DRIVE ..... 18**
- 5. SMART FEATURE SET .....19**
  - 5.1 SMART ATTRIBUTES..... 19**
- 6. PART NUMBER RULE .....21**
- APPENDIX.....22**

## REVISION HISTORY

Revision	Description	Date
Preliminary	First Released	Nov, 2017

## List of Tables

<b>TABLE 1: DEVICE PARAMETERS</b> .....	8
<b>TABLE 2: SEQUENTIAL READ/WRITE PERFORMANCE</b> .....	8
<b>TABLE 3: RANDOM READ/WRITE PERFORMANCE</b> .....	8
<b>TABLE 4: INNODISK M.2 (S80) 3MG5-P POWER REQUIREMENT</b> .....	9
<b>TABLE 5: POWER CONSUMPTION</b> .....	9
<b>TABLE 6: TEMPERATURE RANGE FOR M.2 (S80) 3MG5-P</b> .....	9
<b>TABLE 7: SHOCK/VIBRATION TESTING FOR M.2 (S80) 3MG5-P</b> .....	9
<b>TABLE 8: M.2 (S80) 3MG5-P MTBF</b> .....	10
<b>TABLE 9: INNODISK M.2 (S80) 3MG5-P PIN ASSIGNMENT</b> .....	11
<b>TABLE 10: SMART COMMAND</b> .....	19
<b>TABLE 11: SMART ATTRIBUTE</b> .....	19

## List of Figures

<b>FIGURE 1: INNODISK M.2 (S80) 3MG5-P (TYPE 2280)</b> .....	7
<b>FIGURE 2: M.2 (S80) 3MG5-P MECHANICAL DIAGRAM</b> .....	13
<b>FIGURE 3: INNODISK M.2 (S80) 3MG5-P BLOCK DIAGRAM</b> .....	15
<b>FIGURE 4: SIGNAL SEGMENT AND POWER SEGMENT</b> .....	18

# 1. Product Overview

## 1.1 Introduction of Innodisk M.2 (S80) 3MG5-P

3MG5-P is Innodisk's first product series supported 3D NAND flash. Innodisk M.2 (S80) 3MG5-P is characterized by L3 architecture and RAID engine with the latest SATA III (6.0GHz) ID204 controller. Innodisk's exclusive L3 architecture is L2 architecture multiplied LDPC (Low Density Parity Check). L2 (Long Life) architecture is a 4K mapping algorithm that reduces WAF and features a real-time wear leveling algorithm to provide high performance and prolong lifespan. Innodisk M.2 (S80) 3MG5-P is equipped RAID engine to offer additional level of data protection for exceptional reliability. It is designed for industrial field, and supports several standard features, including TRIM, NCQ, and S.M.A.R.T. In addition, Innodisk's exclusive industrial-oriented firmware provides a flexible customization service, making it perfect for a variety of industrial applications.

## 1.2 Product View and Models

Innodisk M.2 (S80) 3MG5-P is available in follow capacities within MLC flash ICs. 3MG5-P is followed M.2 2280-D2-B-M standard.

[M.2 \(S80\) 3MG5-P 128GB](#)

[M.2 \(S80\) 3MG5-P 256GB](#)

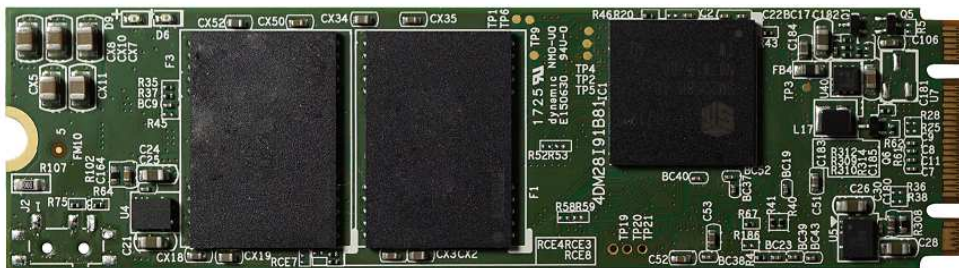

**Figure 1: Innodisk M.2 (S80) 3MG5-P (type 2280)**

## 1.3 SATA Interface

Innodisk M.2 (S80) 3MG5-P supports SATA III interface, and compliant with SATA I and SATA II. SATA III interface can work with Serial Attached SCSI (SAS) host system, which is used in server computer. Innodisk M.2 (S80) 3MG5-P is compliant with Serial ATA Gen 1, Gen 2 and Gen 3 specification (Gen 3 supports 1.5Gbps /3.0Gbps/6.0Gbps data rate).

## 2. Product Specifications

### 2.1 Capacity and Device Parameters

M.2 (S80) 3MG5-P device parameters are shown in Table 1.

**Table 1: Device parameters**

Capacity	Cylinders	Heads	Sectors	LBA	user space
128GB	16383	16	63	234441648	114,473
256GB	16383	16	63	468862128	228,936

### 2.2 Performance

Burst Transfer Rate: 6.0Gbps

**Table 2: Sequential Read/Write Performance**

Specification (max.) (SATA 6Gb/s)	Sequential Read	Sequential Write	Steady Sequential Write
128GB	560 MB/s	500 MB/s	200MB/s
256GB	560 MB/s	520 MB/s	380 MB/s

Note:

1. Sequential performance measured using out-of-box SSD.
2. Performance measured using CrystalDiskMark 5.05 with file size 1000M of Queue Depth 32
3. Steady write performance measured using Everest.

**Table 3: Random Read/Write Performance**

Specification (max.) (SATA 6Gb/s)	Random Read	Random Write
128GB	46000 IOPS	83000 IOPS
256GB	83000 IOPS	87000 IOPS

Note:

1. Sequential performance measured using out-of-box SSD.
2. Performance measured using CrystalDiskMark 5.05 with file size 1000M of Queue Depth 32



## 2.3 Electrical Specifications

### 2.3.1 Power Requirement

**Table 4: Innodisk M.2 (S80) 3MG5-P Power Requirement**

Item	Symbol	Rating	Unit
Input voltage	$V_{IN}$	+3.3 DC +- 5%	V

### 2.3.2 Power Consumption

**Table 5: Power Consumption**

Capacity	Read (mA)	Write(mA)	Idle(mA)	Inrush current
128GB	540	650	230	0.70A (Peak)
256GB	550	1020	260	0.70A (Peak)

## 2.4 Environmental Specifications

### 2.4.1 Temperature Ranges

**Table 6: Temperature range for M.2 (S80) 3MG5-P**

Temperature	Range
Operating	Standard Grade: 0°C to +70°C
Storage	-55°C to +95°C

### 2.4.2 Humidity

Relative Humidity: 10-95%, non-condensing

### 2.4.3 Shock and Vibration

**Table 7: Shock/Vibration Testing for M.2 (S80) 3MG5-P**

Reliability	Test Conditions	Reference Standards
Vibration	7 Hz to 2K Hz, 20G, 3 axes	IEC 68-2-6
Mechanical Shock	Duration: 0.5ms, 1500 G, 3 axes	IEC 68-2-27

### 2.4.4 Mean Time between Failures (MTBF)

Table 8 summarizes the MTBF prediction results for various M.2 (S80) 3MG5-P configurations. The analysis was performed using a RAM Commander™ failure rate prediction.

- **Failure Rate:** The total number of failures within an item population, divided by the total

number of life units expended by that population, during a particular measurement interval under stated condition.

- **Mean Time between Failures (MTBF):** A basic measure of reliability for repairable items: The mean number of life units during which all parts of the item perform within their specified limits, during a particular measurement interval under stated conditions.

**Table 8: M.2 (S80) 3MG5-P MTBF**

Product	Condition	MTBF (Hours)
Innodisk M.2 (S80) 3MG5-P	Telcordia SR-332 GB, 25°C	TBD

## 2.5 CE and FCC Compatibility

M.2 (S80) 3MG5-P conforms to CE and FCC requirements.

## 2.6 RoHS Compliance

M.2 (S80) 3MG5-P is fully compliant with RoHS directive.

## 2.7 Reliability

Parameter	Value	
Read Cycles	Unlimited Read Cycles	
Flash endurance	3,000 P/E cycles	
Wear-Leveling Algorithm	Support	
Bad Blocks Management	Support	
Error Correct Code	Support	
<b>TBW* (Total Bytes Written)</b>	Unit:TB	
<b>Capacity</b>	<b>Sequential workload</b>	<b>Client workload</b>
128GB	340.9	178.5
256GB	681.8	357.1
* Note:		
1. Sequential: Mainly sequential write, tested by Vdbench.		
2. Client: Follow JESD218 Test method and JESD219A Workload, tested by ULINK. (The capacity lower than 64GB client workload is not specified in JEDEC219A, the values are estimated.)		
3. Based on out-of-box performance.		

## 2.8 Transfer Mode

M.2 (S80) 3MG5-P support following transfer mode:

Serial ATA III 6.0Gbps

Serial ATA II 3.0Gbps

Serial ATA I 1.5Gbps

## 2.9 Pin Assignment

Innodisk M.2 (S80) 3MG5-P uses a standard SATA pin-out. See Table 8 for M.2 (S80) 3MG5-P pin assignment.

**Table 9: Innodisk M.2 (S80) 3MG5-P Pin Assignment**

Signal Name	Pin #	Pin #	Signal Name
		75	GND
3.3V	74	73	GND
3.3V	72	71	GND
3.3V	70	69	GND
NC	68	67	NC
Notch	66	65	Notch
Notch	64	63	Notch
Notch	62	61	Notch
Notch	60	59	Notch
NC	58		
NC	56	57	GND
NC	54	55	NC
NC	52	53	NC
NC	50	51	GND
NC	48	49	RX+
NC	46	47	RX-
NC	44	45	GND
NC	42	43	TX-
NC	40	41	TX+
DEVSLP	38	39	GND
NC	36	37	NC
NC	34	35	NC
NC	32	33	GND
NC	30	31	NC
NC	28	29	NC
NC	26	27	GND
NC	24	25	NC
NC	22	23	NC
NC	20	21	GND
Notch	18	19	Notch
Notch	16	17	Notch
Notch	14	15	Notch
Notch	12	13	Notch
DAS/DSS	10	11	NC

NC	8	9	NC
NC	6	7	NC
3.3V	4	5	NC
3.3V	2	3	GND
		1	GND

### 2.10 Mechanical Dimensions

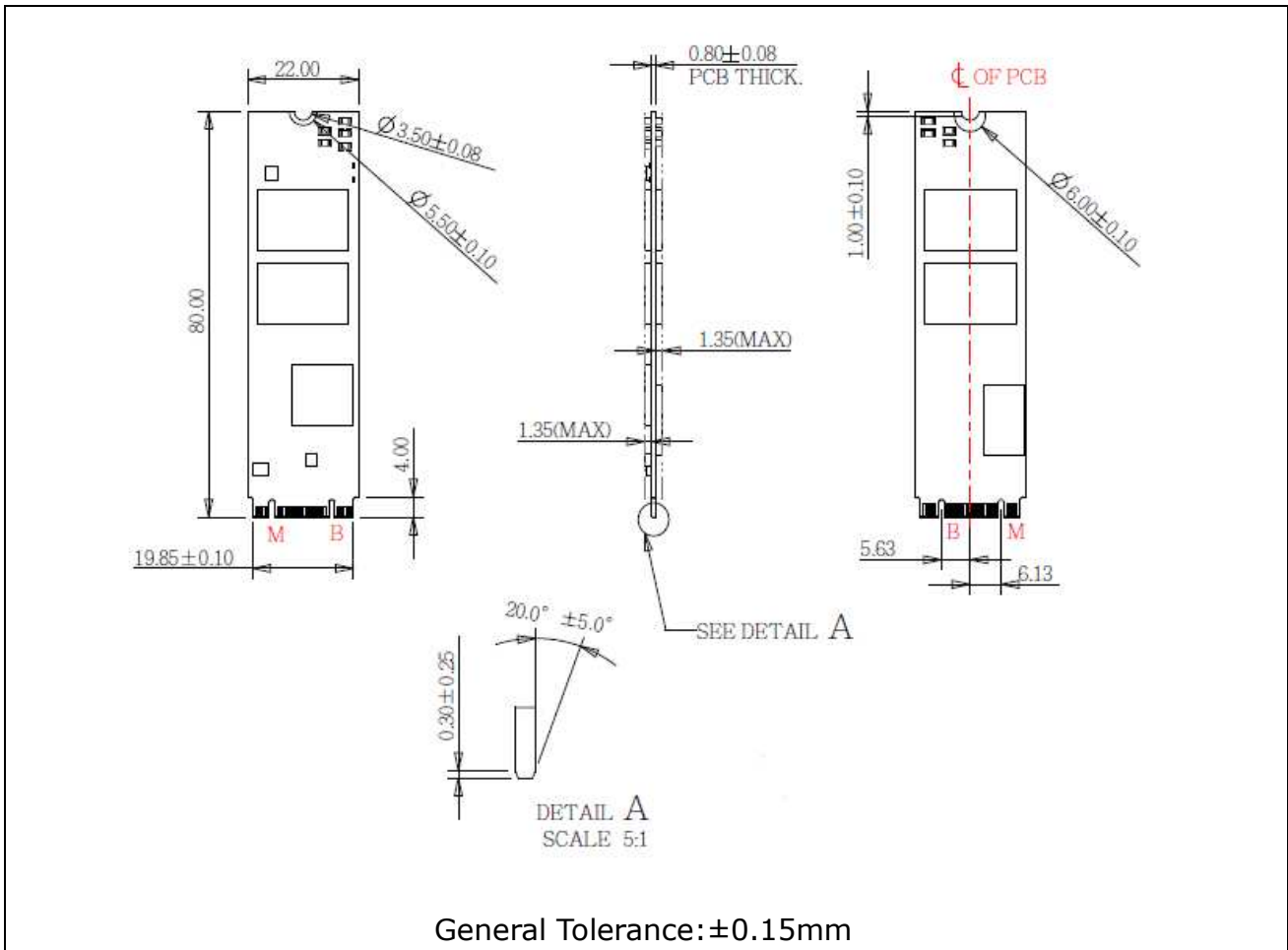

Figure 2: M.2 (S80) 3MG5-P mechanical diagram

## 2.11 Assembly Weight

An Innodisk M.2 (S80) 3MG5-P within flash ICs, 512GB's weight is 12 grams approximately.

## 2.12 Seek Time

Innodisk M.2 (S80) 3MG5-P is not a magnetic rotating design. There is no seek or rotational latency required.

## 2.13 Hot Plug

The SSD support hot plug function and can be removed or plugged-in during operation. User has to avoid hot plugging the SSD which is configured as boot device and installed operation system.

Surprise hot plug : The insertion of a SATA device into a backplane (combine signal and power) that has power present. The device powers up and initiates an OOB sequence.

Surprise hot removal: The removal of a SATA device from a powered backplane, without first being placed in a quiescent state.

## 2.14 NAND Flash Memory

Innodisk M.2 (S80) 3MG5-P uses 3D Multi Level Cell (MLC) NAND flash memory, which is non-volatility, high reliability and high speed memory storage.

# 3. Theory of Operation

## 3.1 Overview

Figure 2 shows the operation of Innodisk M.2 (S80) 3MG5-P from the system level, including the major hardware blocks.

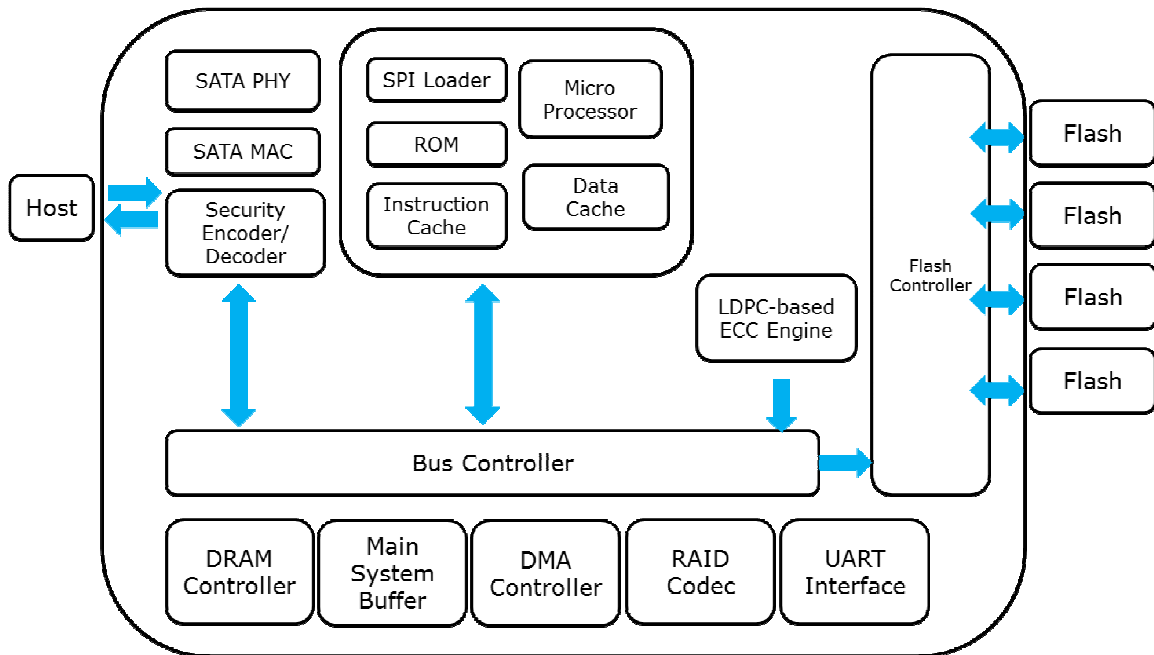

**Figure 3: Innodisk M.2 (S80) 3MG5-P Block Diagram**

Innodisk M.2 (S80) 3MG5-P integrates a SATA III controller and NAND flash memories. Communication with the host occurs through the host interface, using the standard ATA protocol. Communication with the flash device(s) occurs through the flash interface.

## 3.2 SATA III Controller

Innodisk M.2 (S80) 3MG5-P is designed with ID 204, a SATA III 6.0Gbps (Gen. 3) controller, which supports external DDR3 DRAM. The Serial ATA physical, link and transport layers are compliant with Serial ATA Gen 1, Gen 2 and Gen 3 specification (Gen 3 supports 1.5Gbps/3.0Gbps/6.0Gbps data rate). The controller has 4 channels for flash interface.

## 3.3 RAID Protection

In case of uncorrectable errors occurring within a superblock, the RAID engine recovers the uncorrectable error chunk by using a certain storage space of parity bits. Incorporated with LDPC, the RAID ensures a comprehensive level data integrity while providing a broad range of RAID overhead protection.

### 3.4 Error Detection and Correction

Innodisk M.2 (S80) 3MG5-P is designed with hardware LDPC ECC engine with hard-decision and soft-decision decoding. Low-density parity-check (LDPC) codes have excellent error correcting performance close to the Shannon limit when decoded with the belief-propagation (BP) algorithm using soft-decision information.

### 3.5 Wear-Leveling

Flash memory can be erased within a limited number of times. This number is called the **erase cycle limit** or **write endurance limit** and is defined by the flash array vendor. The erase cycle limit applies to each individual erase block in the flash device.

Innodisk M.2 (S80) 3MG5-P uses a static wear-leveling algorithm to ensure that consecutive writes of a specific sector are not written physically to the same page/block in the flash. This spreads flash media usage evenly across all pages, thereby extending flash lifetime.

### 3.6 Bad Blocks Management

Bad Blocks are blocks that contain one or more invalid bits whose reliability are not guaranteed. The Bad Blocks may be presented while the SSD is shipped, or may develop during the life time of the SSD. When the Bad Blocks is detected, it will be flagged, and not be used anymore. The SSD implement Bad Blocks management, Bad Blocks replacement, Error Correct Code to avoid data error occurred. The functions will be enabled automatically to transfer data from Bad Blocks to spare blocks, and correct error bit.

### 3.7 iData Guard

Innodisk's iData Guard is a comprehensive data protection mechanism that functions before and after a sudden power outage to M.2. Low-power detection terminates data writing before an abnormal power-off, while table-remapping after power-on deletes corrupt data and maintains data integrity. Innodisk's iData Guard provides effective power cycling management, preventing data stored in flash from degrading with use.

### 3.8 Garbage Collection/TRIM

Garbage collection and TRIM technology is used to maintain data consistency and perform continual data cleansing on SSDs. It runs as a background process, freeing up valuable controller resources while sorting good data into available blocks, and deleting bad blocks. It also significantly reduces write operations to the drive, thereby increasing the SSD's speed and lifespan.

### 3.9 Thermal Sensor

When the system threatens to overheat, an immediate warning is issued. The SSD will automatically adjusting the transmission frequency to ensure continued performance and reliability.



### 3.10 TRIM

The TRIM command is designed to enable the operating system to notify the SSD which pages no longer contain valid data due to erases either by the user or operating system itself. During a delete operation, the OS will mark the sectors as free for new data and send a TRIM command to the SSD to mark them as not containing valid data. After that the SSD knows not to preserve the contents of the block when writing a page, resulting in less write amplification with fewer writes to the flash, higher write speed, and increased drive life.

# 4. Installation Requirements

## 4.1 M.2 (S80) 3MG5-P Pin Directions

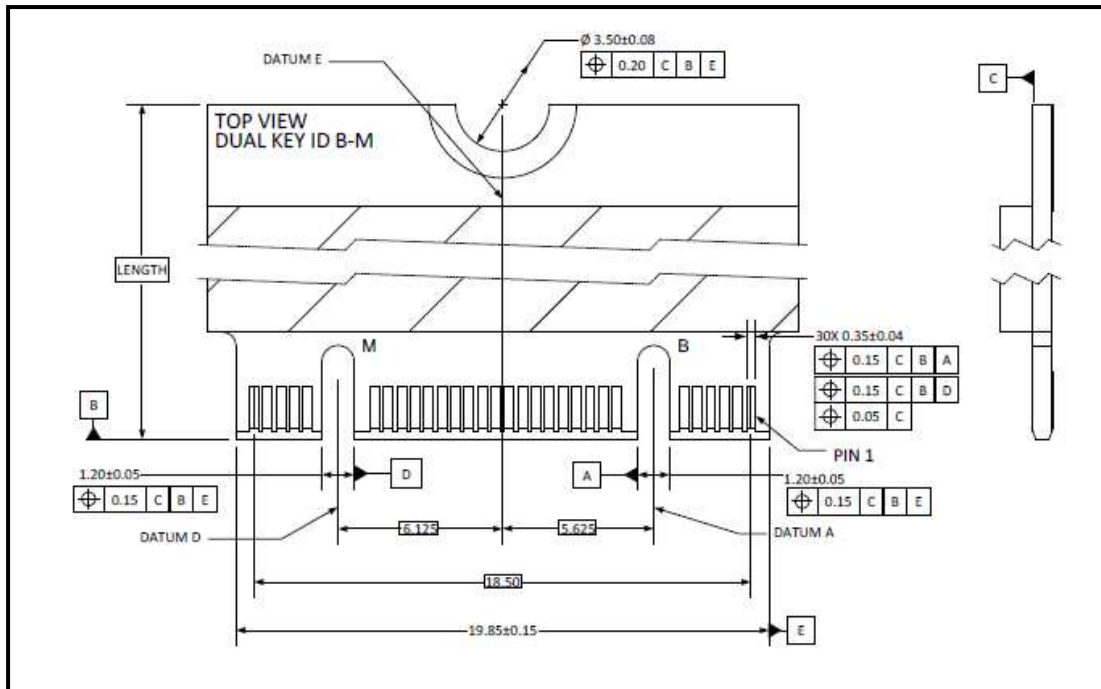

**Figure 4: Signal Segment and Power Segment**

## 4.2 Electrical Connections for M.2 (S80) 3MG5-P

A Serial ATA device may be either directly connected to a host or connected to a host through a cable. For connection via cable, the cable should be no longer than 1meter. The SATA interface has a separate connector for the power supply. Please refer to the pin description for further details.

## 4.3 Device Drive

No additional device drives are required. The Innodisk M.2 (S80) 3MG5-P can be configured as a boot device.

## 5. SMART Feature Set

Innodisk 3MG5-P series support the SMART command set and defines some vendor-specific data to report SMART attributes of SSD.

**Table 10: SMART command**

Value	Command	Value	Command
D0h	Read Data	D5h	Read Log
D1h	Read Attribute Threshold	D6h	Return Status
D2h	Enable/Disable Auto save	D8h	Enable SMART Operations
D3h	Save Attribute Values	D9h	Disable SMART Operations
D4h	Execute OFF-LINE Immediate	DAh	Return Status

### 5.1 SMART Attributes

Innodisk 3MG5-P series SMART data attributes are listed in following table.

**Table 11: SMART attribute**

Attribute ID (hex)	Raw Attribute Value							Attribute Name
	MSB							
1 (01h)	MSB	00	00	00	00	00	00	Raw Read Error Rate
5 (05h)	LSB	MSB	00	00	00	00	00	Reallocated Sector Count
9 (09h)	LSB			MSB	00	00	00	Power-on Hours
12 (0Ch)	LSB			MSB	00	00	00	Power Cycle Count
160 (A0h)	LSB			MSB	00	00	00	Uncorrectable sector count when read/write
161 (A1h)	LSB	MSB	00	00	00	00	00	Number of valid spare block
163 (A3h)	LSB	MSB	00	00	00	00	00	Number of initial invalid block
164 (A4h)	LSB	MSB	00	00	00	00	00	Total erase count
165 (A5h)	LSB			MSB	00	00	00	Maximum erase count
166 (A6h)	LSB			MSB	00	00	00	Minimum erase count
167 (A7h)	LSB			MSB	00	00	00	Average erase count
168 (A8h)	LSB			MSB	00	00	00	Max erase count of spec
169 (A9h)	LSB			MSB	00	00	00	Remain Life (percentage)
175 (AFh)	LSB			MSB	00	00	00	Program fail count in worst die
176 (B0h)	LSB			MSB	00	00	00	Erase fail count in worst die
177 (B1h)	LSB			MSB	00	00	00	Total wear level count
178 (B2h)	LSB	MSB	00	00	00	00	00	Runtime invalid block count
181 (B5h)	LSB			MSB	00	00	00	Total program fail count
182 (B6h)	LSB	MSB	00	00	00	00	00	Total erase fail count
187 (BBh)	LSB			MSB	00	00	00	Uncorrectable error count

192 (C0h)	LSB	MSB	00	00	00	00	00	Power-Off Retract Count
194 (C2h)	MSB	00	00	00	00	00	00	Controlled temperature
195 (C3h)	LSB			MSB	00	00	00	Hardware ECC recovered
196 (C4h)	LSB			MSB	00	00	00	Reallocation event count
198 (C6h)	LSB			MSB	00	00	00	Uncorrectable error count off-line
199 (C7h)	LSB	MSB	00	00	00	00	00	UltraDMA CRC error count
225 (E1h)	LSB						MSB	Total LBAs written (each write unit = 32MB)
232 (E8h)	LSB	MSB	00	00	00	00	00	Available reserved space
241 (F1h)	LSB						MSB	Total LBAs written (each write unit = 32MB)
242 (F2h)	LSB						MSB	Total LBAs read (each write unit = 32MB)

## 6. Part Number Rule

CODE	1	2	3	4	5	6	7	8	9	10	11	12	13	14	15	16	17	18	19	20	21
	D	G	M	2	8	-	A	2	8	D	2	1	C	C	A	Q	G	-	X	X	X
<b>Definition</b>																					
<b>Code 1<sup>st</sup> (Disk)</b>											<b>Code 14<sup>th</sup> (Operation Temperature)</b>										
D : Disk											C: Standard Grade (0°C ~ +70°C)										
<b>Code 2<sup>rd</sup> ~5<sup>th</sup> (Form factor)</b>											<b>Code 15<sup>th</sup> (Internal control)</b>										
GM28: M.2 (S80) 3MG5-P, Type 2280-D2-B-M											A~Z: BGA PCB version.										
<b>Code 7<sup>th</sup> ~9<sup>th</sup> (Capacity)</b>											<b>Code 16<sup>th</sup> (Channel of data transfer)</b>										
A28: 128GB											Q: Quad Channels										
B56: 256GB																					
<b>Code 10<sup>th</sup> ~12<sup>th</sup> (Controller)</b>											<b>Code 17<sup>th</sup> (Flash Type)</b>										
D21: ID204											G: Micron 3D MLC (L06B)										
<b>Code 13<sup>th</sup> (Flash mode)</b>											<b>Code 19<sup>th</sup>~21<sup>st</sup> (Customize code)</b>										
C: 3D NAND with 32 layers																					

# Appendix

## REACH

innodisk

### 宜鼎國際股份有限公司 Innodisk Corporation

Tel: (02) 7703-3000 Fax: (02) 7703-3555 Internet: <http://www.innodisk.com/>

## REACH Declaration of Conformity

### Manufacturer Product: All Innodisk EM Flash and Dram products

1. 宜鼎國際股份有限公司（以下稱本公司）特此保證此售予貴公司之產品，皆符合歐盟化學品法案(Registration, Evaluation and Authorization of Chemicals: REACH)之規定 (<http://www.echa.europa.eu/de/candidate-list-table> last updated: 20/06/2016)。所提供之產品包含：(1) 產品或產品所使用到的所有原物料；(2) 包裝材料；(3) 設計、生產及重工過程中所使用到的所有原物料。

We Innodisk Corporation hereby declare that our products are in compliance with the requirements according to the REACH Regulation

(<http://www.echa.europa.eu/de/candidate-list-table> last updated: 20/06/2016).  
Products include: 1) Product and raw material used by the product; 2) Packaging material; 3) Raw material used in the process of design, production and rework

2. 本公司同意因本保證書或與本保證書相關事宜有所爭議時，雙方宜友好協商，達成協議。

InnoDisk Corporation agrees that both parties shall settle any dispute arising from or in connection with this Declaration of Conformity by friendly negotiations.

### 立 保 證 書 人 (Guarantor)

Company name 公司名稱：InnoDisk Corporation 宜鼎國際股份有限公司

Company Representative 公司代表人：Randy Chien 簡川勝

Company Representative Title 公司代表人職稱：Chairman 董事長

Date 日期：2016 / 06 / 23



## RoHS

innodisk

宜鼎國際股份有限公司  
Innodisk Corporation

Page 1/1

Tel:(02)7703-3000 Fax:(02) 7703-3553 Internet: <http://www.innodisk.com/>

## RoHS 自我宣告書 (RoHS Declaration of Conformity)

## Manufacturer Product: All Innodisk EM Flash and Dram products

- 一、 宜鼎國際股份有限公司（以下稱本公司）特此保證售予貴公司之所有產品，皆符合歐盟 2011/65/EU 關於 RoHS 之規範要求。

Innodisk Corporation declares that all products sold to the company, are complied with European Union RoHS Directive (2011/65/EU) requirement.

- 二、 本公司同意因本保證書或與本保證書相關事宜有所爭議時，雙方宜友好協商，達成協議。

Innodisk Corporation agrees that both parties shall settle any dispute arising from or in connection with this Declaration of Conformity by friendly negotiations.

Name of hazardous substance	Limited of RoHS ppm (mg/kg)
鉛 (Pb)	< 1000 ppm
汞 (Hg)	< 1000 ppm
鎘 (Cd)	< 100 ppm
六價鉻 (Cr 6+)	< 1000 ppm
多溴聯苯 (PBBs)	< 1000 ppm
多溴二苯醚 (PBDEs)	< 1000 ppm

## 立保證書人 (Guarantor)

Company name 公司名稱：Innodisk Corporation 宜鼎國際股份有限公司

Company Representative 公司代表人：Randy Chien 簡川勝

Company Representative Title 公司代表人職稱：Chairman 董事長

Date 日期：2016 / 08 / 04



CE



## VERIFICATION OF COMPLIANCE

*This Verification of Compliance is hereby issued to the below named company. The test results of this report relate only to the tested sample identified in this report.*

**Technical Standard: EMC DIRECTIVE 2014/30/EU  
(EN55022 / EN55024)**

### General Information

Applicant: Innodisk Corporation  
5F., No. 237, Sec. 1, Datong Rd., Xizhi Dist.,  
New Taipei City 22161, Taiwan (R.O.C)

### Product Description

EUT Description: M.2  
Brand Name: Innodisk  
Model Number: M.2 (S80) 3S\*4-&  
(S:Flash type: (S:SLC, I:SLC, M:MLC);  
\*:Product line: (E:Embedded, G:EverGreen, R:InnoRobust);  
#:Controller: ( empty:106/107/167, 2:201/ 202, 3:108/109/170, 4-9:Others);  
&:Product feature: (P:with DRAM, empty:without DRAM))

### Measurement Standard

EN 55022: 2010 / AC: 2011  
EN 61000-3-2: 2014  
EN 61000-3-3: 2013  
EN 55024: 2010  
(IEC 61000-4-2: 2008; IEC 61000-4-3: 2006 + A1: 2007 + A2: 2010; IEC 61000-4-4: 2012;  
IEC 61000-4-5: 2014; IEC 61000-4-6: 2013; IEC 61000-4-8: 2009; IEC 61000-4-11: 2004)

### Measurement Facilities

Xindian Lab.: Compliance Certification Services Inc.  
No.163-1, Zhongsheng Rd., Xindian Dist., New Taipei City, 23131 Taiwan.  
Tel: +886-2-22170894 / Fax: +886-2-22171029

*This device has been shown to be in compliance with and was tested in accordance with the measurement procedures specified in the Standards & Specifications listed above and as indicated in the measurement report number: T160711D02-E*

  
Sam Hu / Assistant Manager  
Date: July 15, 2016

**CCSRF**  
詮智科技股份有限公司  
Compliance Certification Services Inc.



FCC



## VERIFICATION OF COMPLIANCE

*This Verification of Compliance is hereby issued to the below named company. The test results of this report relate only to the tested sample identified in this report.*

**Technical Standard: FCC Part 15 Class B  
IC ICES-003**

### General Information

Applicant: Innodisk Corporation  
5F., No. 237, Sec. 1, Datong Rd., Xizhi Dist.,  
New Taipei City 22161, Taiwan (R.O.C)

### Product Description

EUT Description: M.2  
Brand Name: Innodisk  
Model Number: M.2 (S80) 35\*9-8  
(S:Flash type: (S:SLC,I:SLC,M:MLC);  
\*-Product line: (E:Embedded, G:EverGreen, R:InnoRobust);  
#-Controller: (empty:106/107/167, 2:201/ 202, 3:108/109/170, 4-9:Others);  
&-Product feature: (P:with DRAM, empty:without DRAM))

### Measurement Facilities

Xindian Lab.: Compliance Certification Services Inc.  
No.163-1, Zhongsheng Rd., Xindian Dist., New Taipei City, 23151 Taiwan.  
Tel: +886-2-22170894 / Fax: +886-2-22171029

*This device has been shown to be in compliance with and was tested in accordance with the measurement procedures specified in the Standards & Specifications listed above and as indicated in the measurement report number: T160711D02-D*

*Sam Hu / Assistant Manager*

*Date: July 15, 2016*

群智科技股份有限公司  
Compliance Certification Services Inc.