

1.8" SATA SSD

3SE2-P Series

AES Function

Customer: _____

Customer

Part

Number: _____

Innodisk

Part

Number: _____

Innodisk

Model Name: _____

Date: _____

Innodisk Approver	Customer Approver

**Total Solution For
Industrial Flash Storage**

Table of Contents

1. PRODUCT OVERVIEW	7
1.1 INTRODUCTION OF INNODISK 1.8" SATA SSD 3SE2-P	7
1.2 PRODUCT VIEW AND MODELS	7
1.3 SATA INTERFACE	7
1.4 SATA INTERFACE	8
2. PRODUCT SPECIFICATIONS	9
2.1 CAPACITY AND DEVICE PARAMETERS	9
2.2 PERFORMANCE	9
2.3 ELECTRICAL SPECIFICATIONS	10
2.3.1 Power Requirement	10
2.3.2 Power Consumption	10
2.4 ENVIRONMENTAL SPECIFICATIONS	10
2.4.1 Temperature Ranges	10
2.4.2 Humidity	11
2.4.3 Shock and Vibration	11
2.4.4 Mean Time between Failures (MTBF)	11
2.5 CE AND FCC COMPATIBILITY	11
2.6 RoHS COMPLIANCE	11
2.7 RELIABILITY	11
2.8 TRANSFER MODE	12
2.9 PIN ASSIGNMENT	12
2.10 MECHANICAL DIMENSIONS	13
2.11 ASSEMBLY WEIGHT	13
2.12 SEEK TIME	14
2.13 HOT PLUG	14
2.14 NAND FLASH MEMORY	14
3. THEORY OF OPERATION	15
3.1 OVERVIEW	15
3.2 SATA III CONTROLLER	15
3.3 ERROR DETECTION AND CORRECTION	16
3.4 WEAR-LEVELING	16
3.5 BAD BLOCKS MANAGEMENT	16
3.6 POWER CYCLING	16
3.7 GARBAGE COLLECTION/TRIM	16
3.8 iCELL TECHNOLOGY (OPTIONAL)	16
3.9 1.8" SATA SSD 3SE2-P AES FUNCTION FLOW CHART	16
3.9.1 Encrypted Key Management	17

- 3.9.2 Authorized Key Management..... 11**
- 3.9.3 TCG OPAL..... 18**
- 4. INSTALLATION REQUIREMENTS 19**
- 4.1 1.8" SATA SSD 3SE2-P PIN DIRECTIONS..... 19**
- 4.2 ELECTRICAL CONNECTIONS FOR 1.8" SATA SSD 3SE2-P..... 19**
- 4.3 DEVICE DRIVE 19**
- 5. SMART FEATURE SET 20**
- 6. AES ALGORITHM CERTIFICATION 22**
- 7. PART NUMBER RULE 24**

REVISION HISTORY

Revision	Description	Date
Rev 1.0	First Released	Dec., 2017
Rev 1.1	Revise Performance, Power Consumption	May, 2018

List of Tables

TABLE 1: DEVICE PARAMETERS	9
TABLE 2: PERFORMANCE	9
TABLE 3: INNODISK 1.8" SATA SSD 3SE2-P POWER REQUIREMENT	10
TABLE 4: POWER CONSUMPTION	10
TABLE 5: TEMPERATURE RANGE FOR 1.8" SATA SSD 3SE2-P	10
TABLE 6: SHOCK/VIBRATION TESTING FOR 1.8" SATA SSD 3SE2-P	11
TABLE 7: 1.8" SATA SSD 3SE2-P MTBF	11
TABLE 8: INNODISK 1.8" SATA SSD 3SE2-P PIN ASSIGNMENT	12

List of Figures

FIGURE 1: INNODISK 1.8" SATA SSD 3SE2-P	7
FIGURE 2: INNODISK 1.8" SATA SSD 3SE2-P BLOCK DIAGRAM	15
FIGURE 3: SIGNAL SEGMENT AND POWER SEGMENT	19

1. Product Overview

1.1 Introduction of Innodisk 1.8" SATA SSD 3SE2-P

Innodisk 1.8" SATA SSD 3SE2-P products provide high capacity flash memory Solid State Drive (SSD) that electrically complies with Serial ATA (SATA) standard. It supports SATA III standard (6.0GHz) with high performance. Innodisk 1.8" SATA SSD 3SE2-P is designed with AES engine, which is built-in the controller. When controller receives the data package from host, AES engine encrypts the data package and save the encrypted data into NAND flash. Thus, unauthorized personal has no access to decrypt the data in NAND flash. Innodisk 1.8" SATA SSD 3SE2-P supports several standard features, including TRIM, NCQ, and S.M.A.R.T and compliant with TCG OPAL 2.0 and IEEE 1667.

1.2 Product View and Models

Innodisk 1.8" SATA SSD 3SE2-P is available in follow capacities within SLC flash ICs.

- 1.8" SATA SSD 3SE2-P 8GB
- 1.8" SATA SSD 3SE2-P 16GB
- 1.8" SATA SSD 3SE2-P 32GB
- 1.8" SATA SSD 3SE2-P 64GB
- 1.8" SATA SSD 3SE2-P 128GB
- 1.8" SATA SSD 3SE2-P 256GB
- 1.8" SATA SSD 3SE2-P 512GB



Figure 1: Innodisk 1.8" SATA SSD 3SE2-P

1.3 SATA Interface

Innodisk 1.8" SATA SSD 3SE2-P supports SATA III interface, and compliant with SATA I and SATA II. SATA III interface can work with Serial Attached SCSI (SAS) host system, which is used in server computer. Innodisk 1.8" SATA SSD 3SE2-P is compliant with Serial ATA Gen 1, Gen 2 and Gen 3 specification (Gen 3 supports 1.5Gbps /3.0Gbps/6.0Gbps data rate). SATA connector uses

a 7-pin signal segment and a 9-pin power segment.

1.4 1.8-inch Form Factor

The Industry-standard 1.8-inch form factor is designed with metal material case, which is easy for installation because 1.8-inch is a commonly used form factor in industrial field. Innodisk 1.8" SATA SSD 3SE2-P has a compact design 54.0mm (W) x78.5mm (L) x 5.0mm (H).

2. Product Specifications

2.1 Capacity and Device Parameters

1.8" SATA SSD 3SE2-P device parameters are shown in Table 1.

Table 1: Device parameters

Capacity	LBA	Cylinders	Heads	Sectors	User Capacity(MB)
8GB	14900256	13587	16	63	7275
16GB	30367744	16383	16	63	14828
32GB	61300736	16383	16	63	29932
64GB	123166720	16383	16	63	60140
128GB	246898688	16383	16	63	120556
256GB	494362624	16383	16	63	241388
512GB	989290496	16383	16	63	483052

2.2 Performance

Burst Transfer Rate: 6.0Gbps

Table 2: Performance

Power Voltage 3.3v-

Capacity	8GB	16GB	32GB	64GB	128GB	256GB	512GB
Sequential* Read (max.)	500MB/s	480 MB/s	560 MB/s	560 MB/s	560 MB/s	560 MB/s	560 MB/s
Sequential Write (max.)	120 MB/s	130 MB/s	240 MB/s	330 MB/s	340 MB/s	340 MB/s	360 MB/s
4KB Random Read (QD32)	63,000 IOPS	64,000 IOPS	80,000 IOPS	80,000 IOPS	80,000 IOPS	79,000 IOPS	78,000 IOPS
4KB Random Write (QD32)	31,000 IOPS	34,000 IOPS	66,000 IOPS	69,000 IOPS	72,000 IOPS	72,000 IOPS	73,000 IOPS

Power Voltage 5v-

Capacity	8GB	16GB	32GB	64GB	128GB	256GB	512GB
Sequential* Read (max.)	500MB/s	490 MB/s	560 MB/s	560 MB/s	560 MB/s	560 MB/s	560 MB/s
Sequential Write (max.)	110 MB/s	120 MB/s	240 MB/s	330 MB/s	340 MB/s	340 MB/s	360 MB/s
4KB Random Read (QD32)	63,000 IOPS	64,000 IOPS	80,000 IOPS	79,000 IOPS	79,000 IOPS	80,000 IOPS	78,000 IOPS
4KB Random Write (QD32)	27,000 IOPS	31,000 IOPS	61,000 IOPS	65,000 IOPS	71,000 IOPS	68,000 IOPS	69,000 IOPS

Note: * Sequential performance based on CrystalDiskMark 5.1.2 with file size 1000MB

** Random performance based on IOMeter with Queue Depth 32

2.3 Electrical Specifications

2.3.1 Power Requirement

Table 3: Innodisk 1.8" SATA SSD 3SE2-P Power Requirement

Item	Symbol	Rating	Unit
Input voltage	V _{IN}	+3.3 DC +- 5% +5 DC +- 5%	V

2.3.2 Power Consumption

Table 4: Power Consumption

Mode	Power Consumption(mA)	
	3.3V	5V
Read	450 mA (Max.)	290 mA (Max.)
Write	660 mA (Max.)	470 mA (Max.)
Idle	110 mA (Max.)	120 mA (Max.)

* Target: 1.8" SATA SSD 3SE2-P 512GB

2.4 Environmental Specifications

2.4.1 Temperature Ranges

Table 5: Temperature range for 1.8" SATA SSD 3SE2-P

Temperature	Range
Operating	Standard Grade: 0°C to +70°C
	Industrial Grade: -40°C to +85°C
Storage	-55°C to +95°C

2.4.2 Humidity

Relative Humidity: 10-95%, non-condensing

2.4.3 Shock and Vibration

Table 6: Shock/Vibration Testing for 1.8" SATA SSD 3SE2-P

Reliability	Test Conditions	Reference Standards
Vibration	7 Hz to 2K Hz, 20G, 3 axes	IEC 68-2-6
Mechanical Shock	Duration: 0.5ms, 1500 G, 3 axes	IEC 68-2-27

2.4.4 Mean Time between Failures (MTBF)

Table 7 summarizes the MTBF prediction results for various 1.8" SATA SSD 3SE2-P configurations. The analysis was performed using a RAM Commander™ failure rate prediction.

- **Failure Rate:** The total number of failures within an item population, divided by the total number of life units expended by that population, during a particular measurement interval under stated condition.
- **Mean Time between Failures (MTBF):** A basic measure of reliability for repairable items: The mean number of life units during which all parts of the item perform within their specified limits, during a particular measurement interval under stated conditions.

Table 7: 1.8" SATA SSD 3SE2-P MTBF

Product	Condition	MTBF (Hours)
Innodisk 1.8" SATA SSD 3SE2-P	Telcordia SR-332 GB, 25°C	>3,000,000

2.5 CE and FCC Compatibility

1.8" SATA SSD 3SE2-P conforms to CE and FCC requirements.

2.6 RoHS Compliance

1.8" SATA SSD 3SE2-P is fully compliant with RoHS directive.

2.7 Reliability

Parameter	Value	
Read Cycles	Unlimited Read Cycles	
Flash endurance	60,000 P/E cycles	
Wear-Leveling Algorithm	Support	
Bad Blocks Management	Support	
Error Correct Code	Support	
TBW* (Total Bytes Written) Unit:TB		
Capacity	Sequential workload	Client workload
08GB	426.1	187.5
16GB	852.3	375
32GB	1704.5	750
64GB	3409	1500
128GB	6818.2	3000
256GB	13636.4	6000
512GB	27272.7	12000
*Note:		
1. Sequential: Mainly sequential write, tested by Vdbench.		
2. Client: Follow JESD218 Test method and JESD219A Workload, tested by ULINK. (The capacity lower than 64GB client workload is not specified in JEDEC219A, the values are estimated.)		
3. Based on out-of-box performance.		

2.8 Transfer Mode

1.8" SATA SSD 3SE2-P support the following transfer modes,

Serial ATA III 6.0Gbps

Serial ATA II 3.0Gbps

Serial ATA I 1.5Gbps

2.9 Pin Assignment

Innodisk 1.8" SATA SSD 3SE2-P uses a standard SATA pin-out. See Table 8 for 1.8" SATA SSD 3SE2-P pin assignment.

Table 8: Innodisk 1.8" SATA SSD 3SE2-P Pin Assignment

Name	Type	Description
S1	GND	NA
S2	A+	Differential Signal Pair A
S3	A-	
S4	GND	NA
S5	B-	Differential Signal Pair B
S6	B+	
S7	GND	NA

Key and Spacing separate signal and power segments		
P1	V33	3.3V Power
P2	V33	3.3V Power, Pre-charge
P3	GND	NA
P4	GND	NA
P5	V5	5V Power, Pre-charge
P6	V5	5V Power
P7	R	Reserved
Key	Key	Key
P8	Optional	Write Protect
P9	Optional	Quick Erase

2.10 Mechanical Dimensions

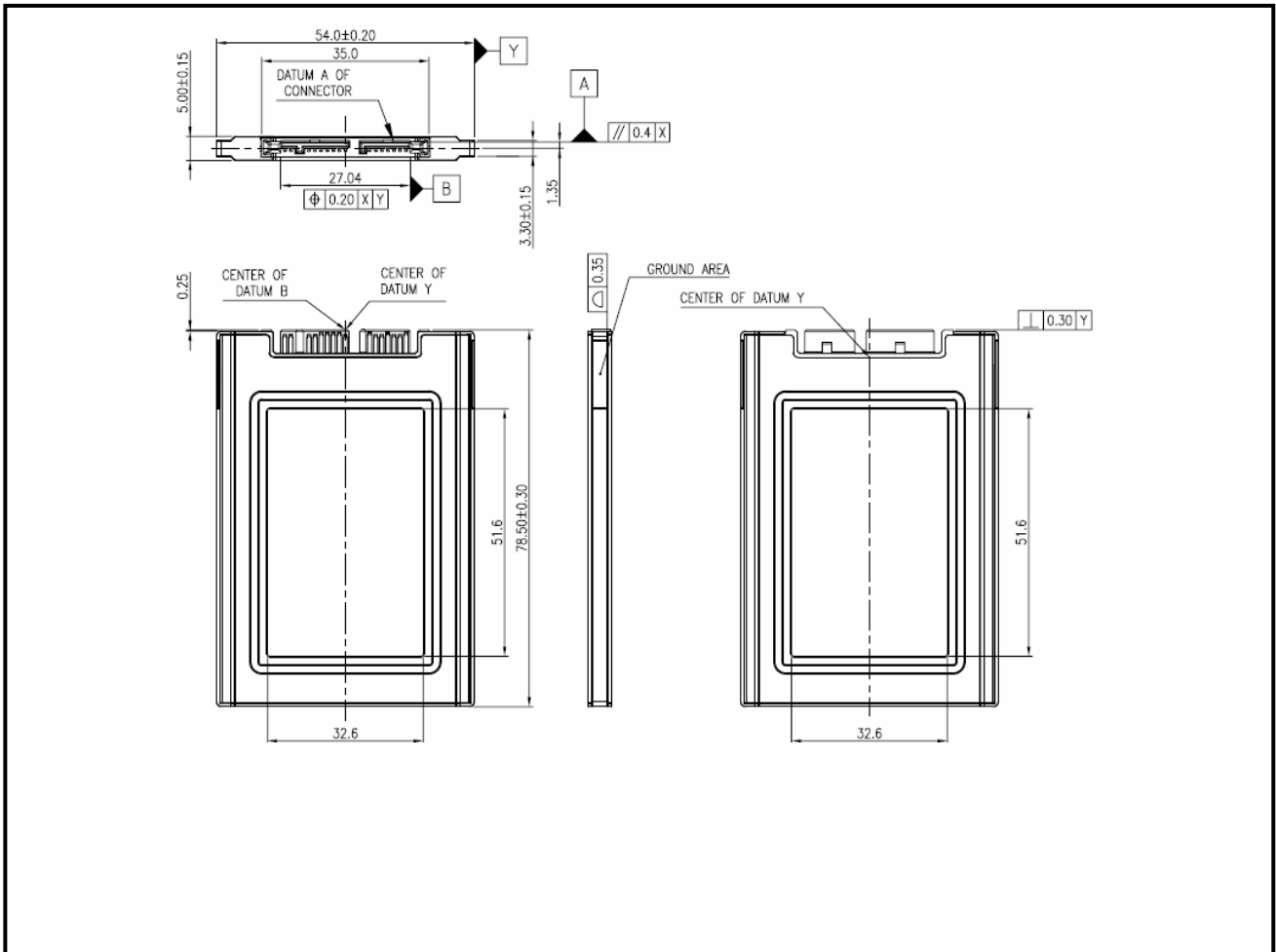

2.11 Assembly Weight

An Innodisk 1.8" SATA SSD 3SE2-P within SLC flash ICs, 32GB's weight is 31 grams approx. The total weight of SSD will be less than 60 grams.

2.12 Seek Time

Innodisk 1.8" SATA SSD 3SE2-P is not a magnetic rotating design. There is no seek or rotational latency required.

2.13 Hot Plug

The SSD support hot plug function and can be removed or plugged-in during operation. User has to avoid hot plugging the SSD which is configured as boot device and installed operation system.

Surprise hot plug : The insertion of a SATA device into a backplane (combine signal and power) that has power present. The device powers up and initiates an OOB sequence.

Surprise hot removal: The removal of a SATA device from a powered backplane, without first being placed in a quiescent state.

2.14 NAND Flash Memory

Innodisk 1.8" SATA SSD 3SE2-P uses Single Level Cell (SLC) NAND flash memory, which is non-volatility, high reliability and high speed memory storage.

3. Theory of Operation

3.1 Overview

Figure 2 shows the operation of Innodisk 1.8" SATA SSD 3SE2-P from the system level, including the major hardware blocks.

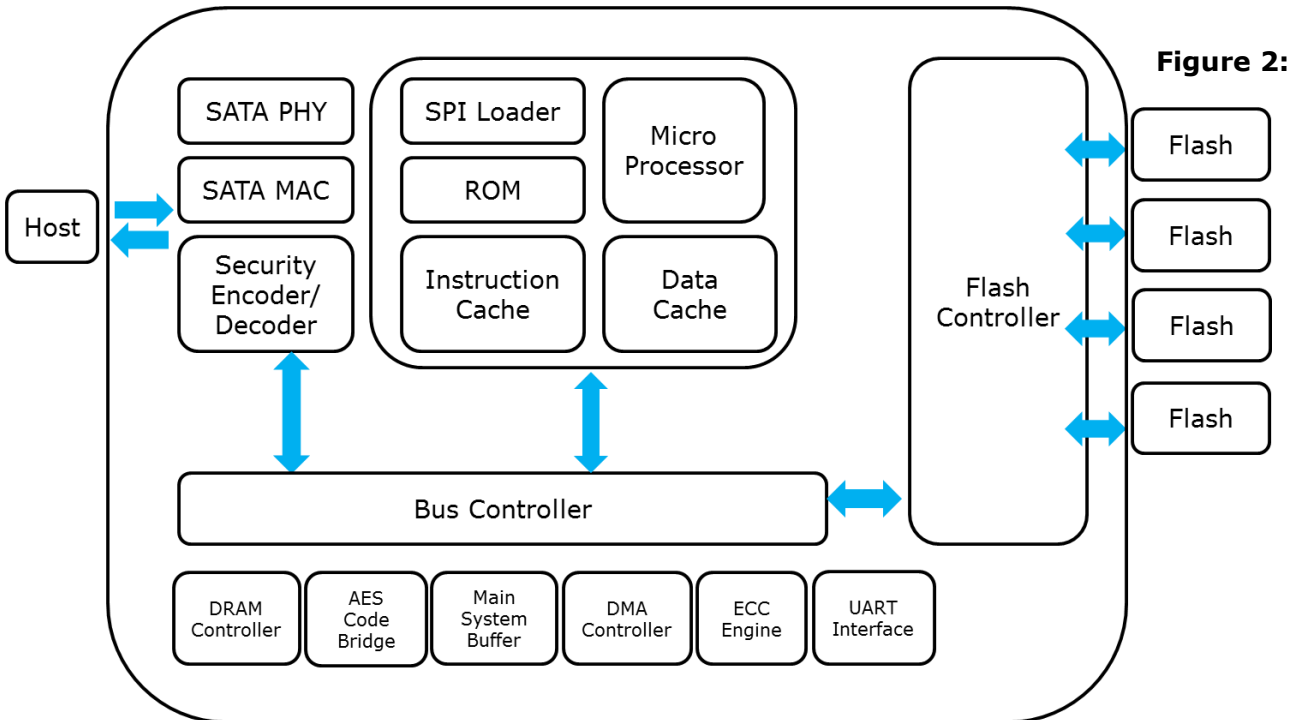

Figure 2:

Innodisk 1.8" SATA SSD 3SE2-P with AES Block Diagram

Innodisk 1.8" SATA SSD 3SE2-P integrates a SATA III controller and NAND flash memories. Communication with the host occurs through the host interface, using the standard ATA protocol. Communication with the flash device(s) occurs through the flash interface. The AES engine was built-in the ID201 controller. When 1.8" SATA SSD 3SE2-P is initiated with Firmware, AES engine will generate a random number to be an AES key. Each SSD has a unique AES key when it leaves the factory.

3.2 SATA III Controller

Innodisk 1.8" SATA SSD 3SE2-P is designed with ID 201 built-in 256bits AES engine, a SATA III 6.0Gbps (Gen. 3) controller, which supports external DDR3 DRAM. The Serial ATA physical, link and transport layers are compliant with Serial ATA Gen 1, Gen 2 and Gen 3 specification (Gen 3 supports 1.5Gbps/3.0Gbps/6.0Gbps data rate). The controller has 4 channels for flash interface.

3.3 Error Detection and Correction

Highly sophisticated Error Correction Code algorithms are implemented. The ECC unit consists of the Parity Unit (parity-byte generation) and the Syndrome Unit (syndrome-byte computation). This unit implements an algorithm that can correct 66 bits per 1024 bytes in an ECC block. Code-byte generation during write operations, as well as error detection during read operation, is implemented on the fly without any speed penalties.

3.4 Wear-Leveling

Flash memory can be erased within a limited number of times. This number is called the **erase cycle limit** or **write endurance limit** and is defined by the flash array vendor. The erase cycle limit applies to each individual erase block in the flash device.

Innodisk 1.8" SATA SSD 3SE2-P uses a static wear-leveling algorithm to ensure that consecutive writes of a specific sector are not written physically to the same page/block in the flash. This spreads flash media usage evenly across all pages, thereby extending flash lifetime.

3.5 Bad Blocks Management

Bad Blocks are blocks that contain one or more invalid bits whose reliability are not guaranteed. The Bad Blocks may be presented while the SSD is shipped, or may develop during the life time of the SSD. When the Bad Blocks is detected, it will be flagged, and not be used anymore. The SSD implement Bad Blocks management, Bad Blocks replacement, Error Correct Code to avoid data error occurred. The functions will be enabled automatically to transfer data from Bad Blocks to spare blocks, and correct error bit.

3.6 iData Guard

Innodisk's iData Guard is a comprehensive data protection mechanism that functions before and after a sudden power outage to SSD. Low-power detection terminates data writing before an abnormal power-off, while table-remapping after power-on deletes corrupt data and maintains data integrity. Innodisk's iData Guard provides effective power cycling management, preventing data stored in flash from degrading with use.

3.7 Garbage Collection/TRIM

Garbage collection and TRIM technology is used to maintain data consistency and perform continual data cleansing on SSDs. It runs as a background process, freeing up valuable controller resources while sorting good data into available blocks, and deleting bad blocks. It also significantly reduces write operations to the drive, thereby increasing the SSD's speed and lifespan.

3.8 iCell Technology (Optional)

iCell circuit is designed with several capacitors to be able to provide power after host power off. The SSD controller can write all DRAM buffer data to flash, so that is why 1.8" SATA SSD 3SE2-P can ensure all data can be written to disk without any data loss.

3.9 1.8" SATA SSD 3SE2-P AES function flow chart

In order to complete the physical security layer of protection, encryption needs to be paired with an ATA user password by ATA security command. After setting the authorized key by ATA security command, every time when you power on the system with SSD encrypted, you will be requested for a password to access the SSD. If the password is correct, the SSD will run well; if not, then you will not be able to access the SSD then.

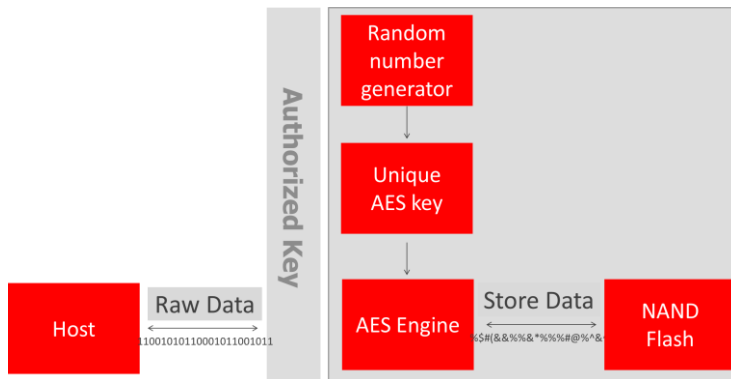

Figure 3: Innodisk 1.8" SATA SSD 3SE2-P AES flow chart

3.9.1 Encrypted Key Management

Innodisk 3SE2-P SSD includes two methods of key management to apply to different applications. The first is a standard approach that allows the firmware to generate a random number and a unique key when it leaves the factory. This method ensures that the user can easily apply the SSD with the data encrypted key. Another approach is to meet unique customer requirements with an encrypted key generated by an SSD from the SATA interface host. The SSD must keep the encrypted key value when receiving the reset commands. This method works best for the SSD as a removable device in different systems. Innodisk provides the test tool to execute the AES hardware encryption. This user-friendly tool, developed by Innodisk Corporation, allows the customer to use/test encryption functions.

3.9.2 Authorized Key Management

In order to complete the physical security layer of protection, encryption needs to be bundled with an ATA user password provided by an ATA Security command. Unlike the AES key, the authorized key must be set by the user via the BIOS configuration. Every time you power on the system with SSD encryption, a password request prompt is sent to access the SSD. If the password is correct, the SSD will run well; if not, you will not be able to access the SSD.

Command	Command Code
SECURITY SET PASSWORD	0XF1
SECURITY UNLOCK	0XF2
SECURITY ERASE PREPARE	0XF3
SECURITY ERASE UNIT	0XF4
SECURITY FREEZE LOCK	0XF5
SECURITY DISABLE PASSWORD	0XF6

3.9.3 TCG OPAL

OPAL is a set of specifications for features of data storage devices that enhance security. These specifications are published by the Trusted Computing Group's Storage Work Group. Innodisk 3SE2-P is compliant with TCG OPAL 2.0^(*1). The capability of TCG OPAL Security mode allows multiple users with independent access control to read/write/erase independent data areas (LBA ranges). Each locking range adjusts by authenticated authority. Note that by default there is a single "Global Range" that encompasses the whole user data area. In TCG Opal Security Mode, Revert, Revert SP and GenKey command can erase all of data including global range and locking range; in the meantime generate the new encrypted key.

*1. You need to install TCG OPAL software to implement OPAL function, which is supplied by TCG OPAL software developed company 2. 2TB doesn't support TCG OPAL

4. Installation Requirements

4.1 1.8" SATA SSD 3SE2-P Pin Directions

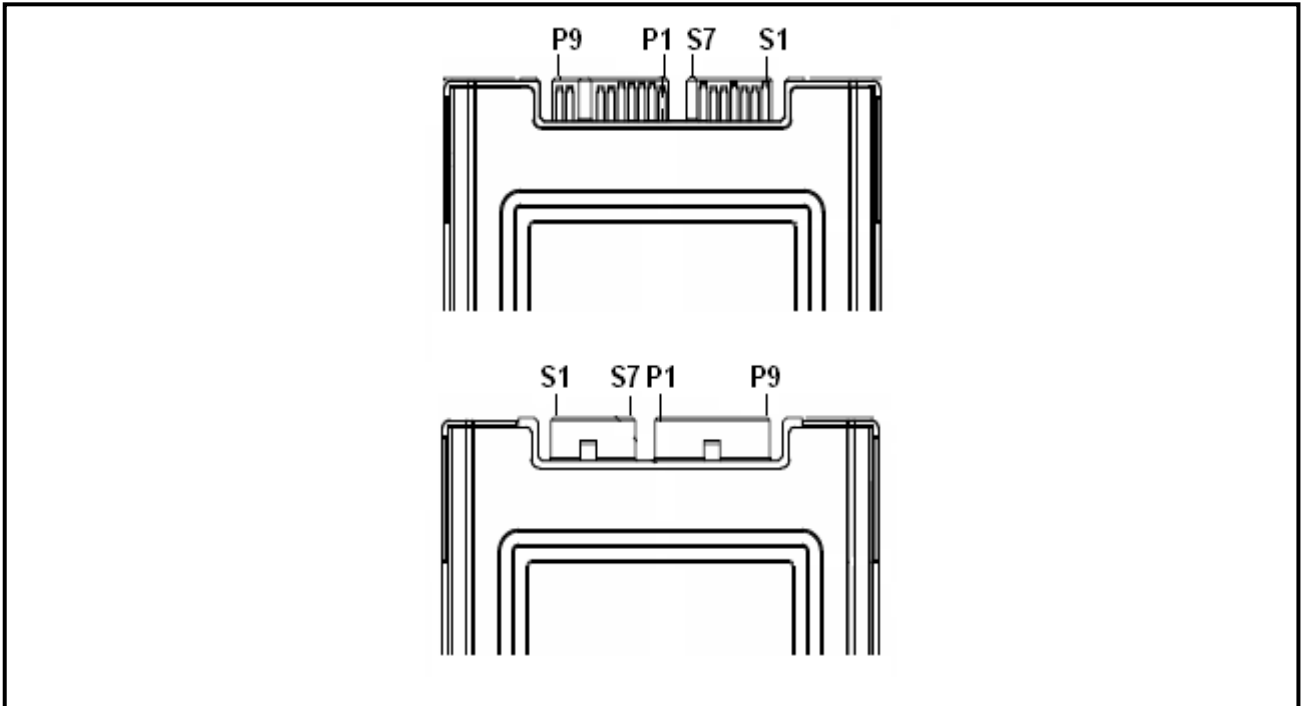

Figure 3: Signal Segment and Power Segment

4.2 Electrical Connections for 1.8" SATA SSD 3SE2-P

A Serial ATA device may be either directly connected to a host or connected to a host through a cable. For connection via cable, the cable should be no longer than 1meter. The SATA interface has a separate connector for the power supply. Please refer to the pin description for further details.

4.3 Device Drive

No additional device drives are required. Innodisk 1.8" SATA SSD 3SE2-P can be configured as a boot device.

5. SMART Feature Set

Innodisk 3SE2-P series support the SMART command set and defines some vendor-specific data to report SMART attributes of SSD.

Value	Command
D0h	Read Data
D1h	Read Attribute Threshold
D2h	Enable/Disable Autosave
D3h	Save Attribute Values
D4h	Execute OFF-LINE Immediate
D5h	Read Log
D6h	Return Status
D8h	Enable SMART Operations
D9h	Disable SMART Operations
DAh	Return Status

5.1 SMART Attributes

Innodisk 3SE2-P series SMART data attributes are listed in following table.

Attribute ID (hex)	Raw Attribute Value							Attribute Name
	MSB							
1 (01h)	MSB	00	00	00	00	00	00	Raw Read Error Rate
5 (05h)	LSB	MSB	00	00	00	00	00	Reallocated Sector Count
9 (09h)	LSB			MSB	00	00	00	Power-on Hours
12 (0Ch)	LSB			MSB	00	00	00	Power Cycle Count
160 (A0h)	LSB			MSB	00	00	00	Uncorrectable sector count when read/write
161 (A1h)	LSB	MSB	00	00	00	00	00	Number of valid spare block
163 (A3h)	LSB	MSB	00	00	00	00	00	Number of initial invalid block
164 (A4h)	LSB	MSB	00	00	00	00	00	Total erase count
165 (A5h)	LSB			MSB	00	00	00	Maximum erase count
166 (A6h)	LSB			MSB	00	00	00	Minimum erase count
167 (A7h)	LSB			MSB	00	00	00	Average erase count
168 (A8h)	LSB			MSB	00	00	00	Max erase count of spec
169 (A9h)	LSB			MSB	00	00	00	Reman Life (percentage)
175 (AFh)	LSB			MSB	00	00	00	Program fail count in worst die
176 (B0h)	LSB			MSB	00	00	00	Erase fail count in worst die
177 (B1h)	LSB			MSB	00	00	00	Total wear level count

178 (B2h)	LSB	MSB	00	00	00	00	00	Runtime invalid block count
181 (B5h)	LSB			MSB	00	00	00	Total program fail count
182 (B6h)	LSB	MSB	00	00	00	00	00	Total erase fail count
187 (BBh)	LSB			MSB	00	00	00	Uncorrectable error count
192 (C0h)	LSB	MSB	00	00	00	00	00	Power-Off Retract Count
194 (C2h)	MSB	00	00	00	00	00	00	Controlled temperature
195 (C3h)	LSB			MSB	00	00	00	Hardware ECC recovered
196 (C4h)	LSB			MSB	00	00	00	Reallocation event count
198 (C6h)	LSB			MSB	00	00	00	Uncorrectable error count off-line
199 (C7h)	LSB	MSB	00	00	00	00	00	UltraDMA CRC error count
225 (E1h)	LSB						MSB	Total LBAs written (each write unit = 32MB)
232 (E8h)	LSB	MSB	00	00	00	00	00	Available reserved space
241 (F1h)	LSB						MSB	Total LBAs written (each write unit = 32MB)
242 (F2h)	LSB						MSB	Total LBAs read (each write unit = 32MB)

6. AES Algorithm Certification

The following provides technical information about controller implementations that have been validated as confirming to the Advanced Encryption Standard (AES) Algorithm, Deterministic Random Bit Generator (DRBG) Algorithm, and Secure Hash Standard (SHS).

6.1 AES Algorithm

Val. No	Operational Environment	Val. Date	Modes/States/Key sizes/Description/Notes
2474	Cadence NC-verilog hardware simulator v10.20	May/24/2013	Using the tests found in The Advanced Encryption Standard Algorithm Validation Suite (AESAVS). This testing is performed by NVLAP accredited Cryptographic And Security Testing (CST) Laboratories. ECB (e/d; 128, 192, 256) XTS (KS: XTS_128) KS: XTS_256

6.2 DRBG Algorithm

Val. No	Operational Environment	Val. Date	Modes/States/Key sizes/Description/Notes
337	Cadence NC-verilog hardware simulator v10.20	May/24/2013	Using the tests found in The DRBG Validation Suite (DRBGVS). This testing is performed by NVLAP accredited Cryptographic And Security Testing (CST) Laboratories. HashBased DRBG: Prediction Resistance Tested: enabled and not enabled (SHA-256)

6.3 SHS Algorithm

Val. No	Operational Environment	Val. Date	Modes/States/Key sizes/Description/Notes
2093	Cadence NC-verilog hardware simulator v10.20	May/24/2013	Has been validated as confirming to the Secure Hash Algorithm specified in Federal Information Processing Standard (FIPS) 180-3, Secure Hash Standard (SHS), using tests described in the

			<p>Secure Hash Algorithm Validation System (SHAVS). This testing is performed by NVLAP accredited Cryptographic And Security Testing (CST) Laboratories. SHA-256</p>
--	--	--	--

7. Part Number Rule

CODE	1	2	3	4	5	6	7	8	9	10	11	12	13	14	15	16	17	18	19	20	21
	D	E	S	1	8	-	3	2	G	D	8	2	S	C	A	Q	B	(P)	-	X	X
Description	Disk	1.8" SATA SSD 3SE2-P					Capacity			Category		Flash mode	Operation Temp.	Internal Control	CH.	Flash	icell			Customized Code	
Definition																					
Code 1st (Disk)											Code 14th (Operation Temperature)										
D : Disk											C: Standard Grade (0°C ~ +70°C)										
Code 2nd ~ 5th (Form Factor)											Code 15th (Internal control)										
ES18: 1.8" SATA SSD 3SE2-P											W: Industrial Grade (-40°C ~ +85°C)										
Code 7th ~9th (Capacity)											Code 16th (Channel of data transfer)										
08G: 8GB											A: PCB version for voltage 3.3v										
16G: 16GB											B: PCB version for voltage 5v										
32G: 32GB											Code 17th (Flash Type)										
64G: 64GB											Q: Quad Channels										
A28: 128GB																					
B56: 256GB																					
C12:512GB																					
Code 10th ~12th (Series)											Code 18th (iCell)										
D82: 1.8" SATA SSD 3SE2-P with AES engine											B: Toshiba SLC										
Code 13th (Firmware version)											T: Micron SLC										
S: Synchronous Flash											Code 20th ~21th (Customized code)										
											P: iCell, reserved for optional function										

Appendix

RoHS 自我宣告書 (RoHS Declaration of Conformity)

Manufacturer Product: All Innodisk EM Flash and Dram products

- 一、 宜鼎國際股份有限公司（以下稱本公司）特此保證售予貴公司之所有產品，皆符合歐盟 2011/65/EU 及 (EU) 2015/863 關於 RoHS 之規範要求。

Innodisk Corporation declares that all products sold to the company, are complied with European Union RoHS Directive (2011/65/EU) and (EU) 2015/863 requirement.

- 二、 本公司同意因本保證書或與本保證書相關事宜有所爭議時，雙方宜友好協商，達成協議。

Innodisk Corporation agrees that both parties shall settle any dispute arising from or in connection with this Declaration of Conformity by friendly negotiations.

Name of hazardous substance	Limited of RoHS ppm (mg/kg)
鉛 (Pb)	< 1000 ppm
汞 (Hg)	< 1000 ppm
鎘 (Cd)	< 100 ppm
六價鉻 (Cr 6+)	< 1000 ppm
多溴聯苯 (PBBs)	< 1000 ppm
多溴二苯醚 (PBDEs)	< 1000 ppm
鄰苯二甲酸二(2-乙基己基)酯 (DEHP)	< 1000 ppm
鄰苯二甲酸丁酯苯甲酯 (BBP)	< 1000 ppm
鄰苯二甲酸二丁酯 (DBP)	< 1000 ppm
鄰苯二甲酸二異丁酯 (DIBP)	< 1000 ppm

立 保 證 書 人 (Guarantor)

Company name 公司名稱： Innodisk Corporation 宜鼎國際股份有限公司

Company Representative 公司代表人： Randy Chien 簡川勝

Company Representative Title 公司代表人職稱： Chairman 董事長

Date 日期： 2017 / 01 / 18



宜鼎國際股份有限公司
Innodisk Corporation

Tel:(02)7703-3000 Fax:(02) 7703-3555 Internet: <http://www.innodisk.com/>

REACH Declaration of Conformity

Manufacturer Product: All Innodisk EM Flash and Dram products

1. 宜鼎國際股份有限公司（以下稱本公司）特此保證此售予貴公司之產品，皆符合歐盟化學品法案(Registration , Evaluation and Authorization of Chemicals ; (EC) No 1907/2006 REACH) 以及附錄 XIV 中的限用物質之規定 (<http://www.echa.europa.eu/de/candidate-list-table> last updated: 12/01/2017 , SVHC's 173)。

所提供之產品包含：(1) 產品或產品所使用到的所有原物料；(2)包裝材料；(3)設計、生產及重工過程中所使用到的所有原物料。

We Innodisk Corporation hereby declare that our products are in compliance with the requirements according to the (EC) No 1907/2006 REACH Regulation and restricted substances in Annex XIV (<http://www.echa.europa.eu/de/candidate-list-table> last updated: 12/01/2017 , SVHC's 173).

Products include : 1) Product and raw material used by the product ; 2) Packaging material ; 3) Raw material used in the process of design, production and rework.

2. 本公司同意因本保證書或與本保證書相關事宜有所爭議時，雙方宜友好協商，達成協議。InnoDisk Corporation agrees that both parties shall settle any dispute arising from or in connection with this Declaration of Conformity by friendly negotiations.

立 保 證 書 人 (Guarantor)

Company name 公司名稱： InnoDisk Corporation 宜鼎國際股份有限公司

Company Representative 公司代表人： Randy Chien 簡川勝

Company Representative Title 公司代表人職稱： Chairman 董事長

Date 日期： 2017 / 02 / 08



Certificate

Issue Date: March 1, 2016
Ref. Report No. ISL-16LE078CE

Product Name : 1.8" SATA SSD
Model(s) : 1.8" SATA SSD 3\$*#-&
(\$:Flash type: (S:SLC,I:iSLC,M:MLC);
*:Product line: (E:Embedded, G:EverGreen, R:InnoRobust);
#:Controller: (empty:106/107/167, 2:201/202, 3:108/109/170, 4~9:Others)
&:Product feature: (P:with DRAM, empty:without DRAM)

Responsible Party : Innodisk Corporation
Address : 5F., No.237, Sec. 1, Datong Rd., Xizhi Dist., New Taipei City 221,
Taiwan (R.O.C.)

We, **International Standards Laboratory**, hereby certify that:

The device bearing the trade name and model specified above has been shown to comply with the applicable technical standards as indicated in the measurement report and was tested in accordance with the measurement procedures specified in European Council Directive- EMC Directive 2004/108/EC (marketed before 2016/04/19) 2014/30/EU (marketed after 2016/04/20). The device was passed the test performed according to :



Standards:

EN 55022: 2010+AC2011 and CISPR 22: 2008 (modified)
EN 61000-3-2:2014 and IEC 61000-3-2:2014
EN 61000-3-3: 2013 and IEC 61000-3-3: 2013
EN 55024: 2010 and CISPR 24: 2010
EN 61000-4-2: 2009 and IEC 61000-4-2: 2008
EN 61000-4-3: 2006+A1: 2008 +A2: 2010 and
IEC 61000-4-3:2006+A1: 2007+A2: 2010
EN 61000-4-4:2012 and IEC 61000-4-4:2012

I attest to the accuracy of data and all measurements reported herein were performed by me or were made under my supervision and are correct to the best of my knowledge and belief. I assume full responsibility for the completeness of these measurements and vouch for the qualifications of all persons taking them.

International Standards Laboratory

W.H. Chang / Director

Hsi-Chih LAB:

No. 65, Gu Dai Keng Street, Hsi-Chih Dist.,
New Taipei City 221, Taiwan
Tel: 886-2-2646-2550; Fax: 886-2-2646-4641



Lung-Tan LAB:

No. 120, Lane 180, Hsin Ho Rd., Lung-Tan Dist.,
Tao Yuan City 325, Taiwan
Tel: 886-3-407-1718; Fax: 886-3-407-1738



Certificate

Issue Date: March 1, 2016
Ref. Report No. ISL-16LE078FB

Product Name : 1.8" SATA SSD
Model(s) : 1.8" SATA SSD 3\$*#-&
(\$:Flash type: (S:SLC,I:iSLC,M:MLC);
*:Product line: (E:Embedded, G:EverGreen, R:InnoRobust);
#:Controller: (empty:106/107/167, 2:201/202, 3:108/109/170, 4~9:Others)
&:Product feature: (P:with DRAM, empty:without DRAM)

Applicant : Innodisk Corporation
Address : 5F., No.237, Sec. 1, Datong Rd., Xizhi Dist., New Taipei City 221,
Taiwan (R.O.C.)

We, **International Standards Laboratory**, hereby certify that:

The device bearing the trade name and model specified above has been shown to comply with the applicable technical standards as indicated in the measurement report and was tested in accordance with the measurement procedures specified. (refer to Test Report if any modifications were made for compliance).



Standards:

FCC CFR Title 47 Part 15 Subpart B: 2014- Section 15.107 and 15.109
ANSI C63.4-2014
Industry Canada Interference-Causing Equipment Standard ICES-003 Issue 6: 2016

Class B

I attest to the accuracy of data and all measurements reported herein were performed by me or were made under my supervision and are correct to the best of my knowledge and belief. I assume full responsibility for the completeness of these measurements and vouch for the qualifications of all persons taking them.

International Standards Laboratory

W.H. Chang / Director

Hsi-Chih LAB:

No. 65, Gu Dai Keng Street, Hsi-Chih Dist.,
New Taipei City 221, Taiwan
Tel: 886-2-2646-2550; Fax: 886-2-2646-4641



Lung-Tan LAB:

No. 120, Lane 180, Hsin Ho Rd., Lung-Tan Dist.,
Tao Yuan City 325, Taiwan
Tel: 886-3-407-1718; Fax: 886-3407-1738

